

**LTE Cat-1**

**Dual Band Module**

**CL32DAH31**

**Data Report**

**TAIYO YUDEN**

## ●Contents

1. Introduction .....	- 4 -
2. Overall Description .....	- 5 -
2.1. Function Overview .....	- 5 -
2.2. Circuit Block Diagram .....	- 6 -
3. Description of the Application Interfaces .....	- 7 -
3.1. pin .....	- 7 -
3.2. Power Management Unit (PMU) .....	- 15 -
3.2.1. Overview .....	- 15 -
3.2.2. USIM Power Output UIM_VCC .....	- 15 -
3.3. Signal Control Interface .....	- 16 -
3.3.1. Overview .....	- 16 -
3.3.2. RESET Pin .....	- 17 -
3.3.3. WAKEUP_OUT Pin .....	- 17 -
3.3.4. WAKEUP_IN Pin .....	- 17 -
3.3.5. RSTN Pin .....	- 17 -
3.3.6. ALARMZ Pin .....	- 18 -
3.3.7. RETLE_N_OUT Pin .....	- 18 -
3.4. USB Interface .....	- 18 -
3.5. UART Interface .....	- 19 -
3.6. USIM Card Interface .....	- 20 -
3.6.1. Overview .....	- 20 -
3.6.2. Circuit Recommended for the USIM Card Interface .....	- 20 -
3.7. RF Antenna Interface .....	- 21 -
3.7.1. RF Connector location .....	- 21 -
4. RF Specifications .....	- 22 -
4.1. Operating Frequencies .....	- 22 -
4.2. Test Standards .....	- 22 -
4.3. RF Specifications .....	- 22 -
5. Electrical Specifications .....	- 23 -
5.1. Absolute Maximum Ratings .....	- 23 -
5.2. Operating Conditions .....	- 23 -
5.3. Power Supply .....	- 24 -
5.3.1. Input Power Supply .....	- 24 -
5.3.2. Power Consumption .....	- 24 -
5.3.3. Power Consumption .....	- 25 -
6. Function and Features .....	- 26 -
6.1. Power on/off .....	- 26 -
6.1.1. Power on .....	- 26 -

6.1.2. Power off .....	- 26 -
6.2. Host-Module Mutual Wakeup Interface for UART .....	- 27 -
7. Mechanical Specifications .....	- 28 -
7.1. Dimensions of the module.....	- 28 -
7.2. Label .....	- 29 -
7.3. Packing System.....	- 30 -
8. Handling Precautions.....	- 31 -
8.1. Thermal Management .....	- 31 -
8.2. Desire and Conditions .....	- 31 -
8.2.1. Environment conditions for use and storage .....	- 31 -
8.2.2. Conditions for handling of products.....	- 31 -
9. Certifications .....	- 33 -
9.1. Certifications.....	- 33 -
10. Safety Information.....	- 34 -
10.1. Interference .....	- 34 -
10.2. Medical Device .....	- 34 -
10.3. Area with Inflammables and Explosives .....	- 34 -
10.4. Airline Security.....	- 35 -
10.5. Safety of Children.....	- 35 -
10.6. Environment Protection .....	- 35 -
10.7. RoHS Approval.....	- 35 -
10.8. Laws and Regulations Observance.....	- 35 -
10.9. Care and Maintenance .....	- 35 -
10.10. Emergency Call.....	- 35 -
Appendix. Acronyms and Abbreviations .....	- 36 -

# 1. Introduction

TAIYO YUDEN offers a turnkey solution of CAT-1 dual band LGA module supporting the following key features:

## Module highlights

- Based on Altair Semiconductor ALT1160L chipset
- LTE CAT-1
- Supporting standard dual band design for docomo
  - 1 x Band19 (800MHz)
  - 1 x Band1 (2GHz)
- Small size (module size 26.0mm x 20.0 mm x 2.4 mm)
- Power supply: 2.3V-4.2V (VBAT\_L) / 3.4V-4.2V (VBAT\_H)
- Supports DRX, eDRX and standby ultra-low power consumption

## LTE features highlights

- LTE CAT-1 support based on 3GPP release10 + eDRX
- Embedded IMS
- Embedded network processor

## Features

- TCP/IP, UDP/IP, SSL/TLS 1.2, IPv4/IPv6 dual-stack, SMS, Power saving

## Interface support

- USB2.0, 2/4 wires UART, GPIO

This document describes the hardware application interfaces and air interfaces that are provided when the module is used.

This document helps you to understand the interface specifications, electrical features and related product information of the module.

## 2. Overall Description

### 2.1. Function Overview

**Table1 Features**

Feature	Description
Physical Features	Dimensions:26.0mm × 20.0mm × 2.4mm
Weight	2.8g
Operating Bands	LTE: FDD Band1,19, all bands with Rx diversity
Operating Temperature	-30°C to +70°C
Storage Temperature	-40°C to +80°C
Power Voltage	VBAT_L: 2.3V to 4.2V <sup>[1]</sup> VBAT_H: 3.4V to 4.2V <sup>[1]</sup>
Application Interface	USIM
	USB2.0 (High-Speed)
	UART1 for AT
	UART2 for CLI
	Host Interface
SMS	Supports formats of PDU (AT command) SMS over SGs
Data Services	DL: 10Mbps (OFDMA) / UL: 5Mbps (SC-FDMA) <sup>[2]</sup>
Operating System	Linux

<sup>[1]</sup>: Power voltage of our evaluation board is as follows; VBAT\_L: 3.0V  
VBAT\_H: 3.4V

<sup>[2]</sup>: the maximum value in theory

#### NOTE

- Use external interface for debugging and rewriting FW.

## 2.2. Circuit Block Diagram

Figure1 shows the circuit block diagram of the module. The application block diagram and major functional units of the module contain the following parts:

- Radio Frequency (RF) transceiver
- Multi-chip package (MCP) include power management unit
- RF Front End

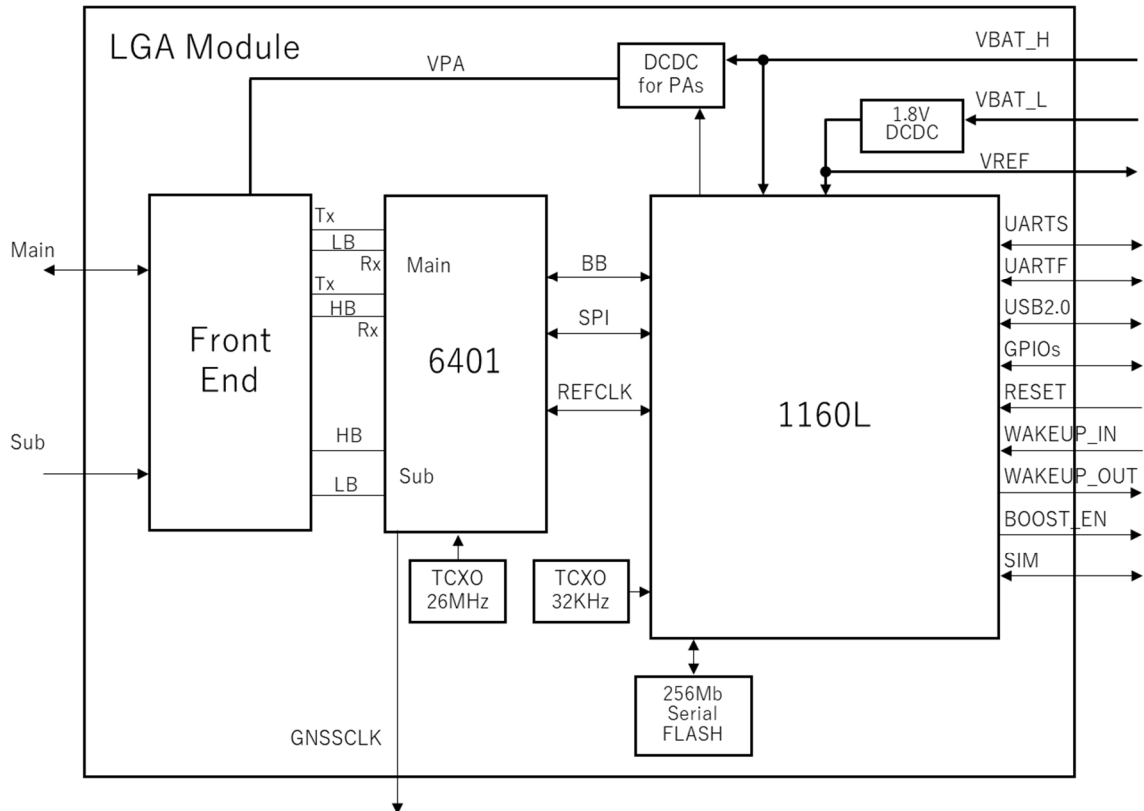

Figure1 Circuit block diagram of the module

### 3. Description of the Application Interfaces

#### 3.1. pin

The module uses pins as its external interfaces.

Figure2 shows an LGA map diagram of this module.

Table2 shows definitions of pins on the LGA map.

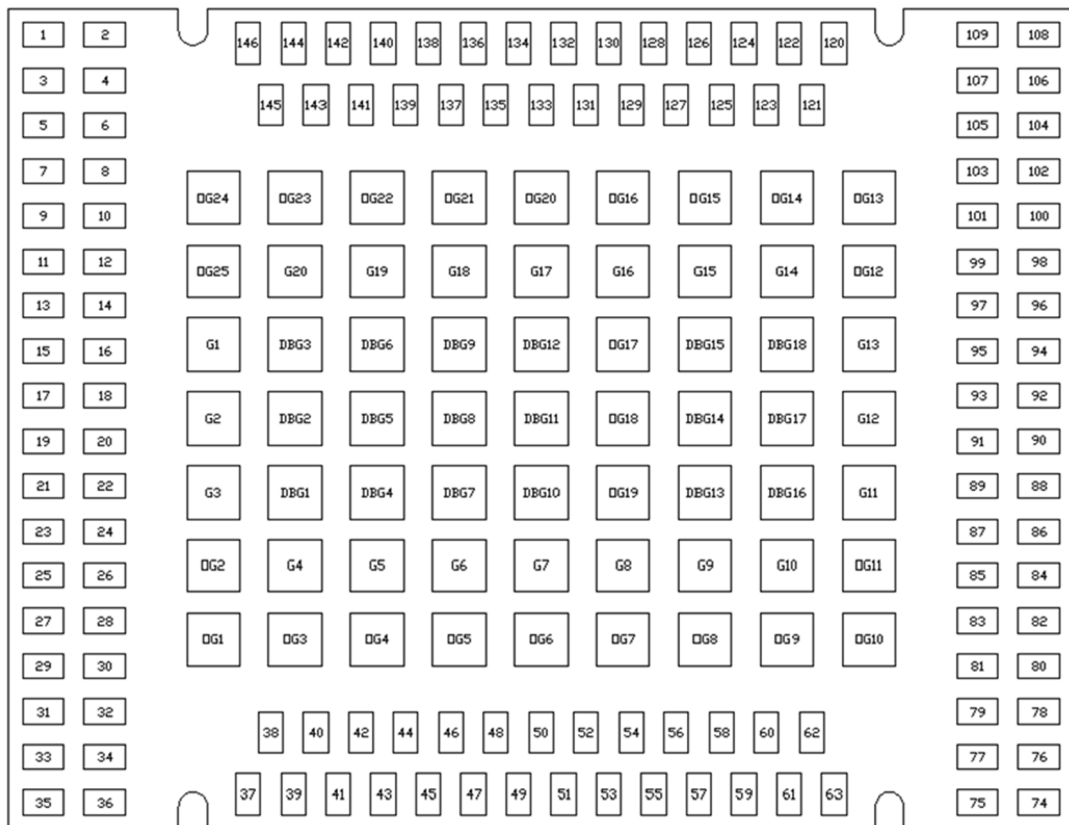

Figure2 LGA map diagram (TOP\_THRU\_VIEW)

**Table2 Definitions of pins**

No.	Pin Name	Direction	Type	Reset Value	Recommendation for Unused pin	Description
1	GND	-	-	-	-	Ground
2	GND	-	-	-	-	Ground
3	NC	-	-	-	Open	Not connected. It is better to solder.
4	GND	-	-	-	-	Ground
5	GND	-	-	-	-	Ground
6	GND	-	-	-	-	Ground
7	GND	-	-	-	-	Ground
8	GND	-	-	-	-	Ground
9	NC	-	-	-	Open	Not connected. It is better to solder.
10	GND	-	-	-	-	Ground
11	GND	-	-	-	-	Ground
12	GND	-	-	-	-	Ground
13	GND	-	-	-	-	Ground
14	GND	-	-	-	-	Ground
15	RF_1	-	A	-	-	RF TRX, main LTE antenna
16	GND	-	-	-	-	Ground
17	GND	-	-	-	-	Ground
18	GND	-	-	-	-	Ground
19	GND	-	-	-	-	Ground
20	GND	-	-	-	-	Ground
21	RF_2	-	A	-	-	RF RX, RX only LTE antenna
22	GND	-	-	-	-	Ground
23	GND	-	-	-	-	Ground
24	GND	-	-	-	-	Ground
25	GND	-	-	-	-	Ground
26	GND	-	-	-	-	Ground
27	NC	-	-	-	Open	Not connected. It is better to solder.
28	GND	-	-	-	-	Ground
29	GND	-	-	-	-	Ground
30	GND	-	-	-	-	Ground
31	GND	-	-	-	-	Ground
32	GND	-	-	-	-	Ground



No.	Pin Name	Direction	Type	Reset Value	Recommendation for Unused pin	Description
33	NC	-	-	-	Open	Not connected. It is better to solder.
34	GND	-	-	-	-	Ground
35	GND	-	-	-	-	Ground
36	GND	-	-	-	-	Ground
37	VCC1	I	P	-	-	VBAT_L Power Module input voltage range 2.3V – 4.2V.
38	VCC2	I	P	-	-	
39	VCC3	I	P	-	-	VBAT_H Power Module input voltage range 3.4V – 4.2V.
40	VCC4	I	P	-	-	
41	VCC5	I	P	-	-	
42	VCC6	I	P	-	-	
43	NC	-	-	-	Open	Not connected. It is better to solder.
44	GND	-	-	-	-	Ground
45	GND	-	-	-	-	Ground
46	GPIO3/PCM_FS	O	D	PD	Open	Reserved
47	GPIO2/PCM_DIN	I	D	PU	Open	Reserved
48	GPIO1/PCM_DOUT	O	D	PU	Open	Reserved
49	GPIO0/PCM_CLK	O	D	PD	Open	Reserved
50	GND	-	-	-	-	Ground
51	GND	-	-	-	-	Ground
52	RFFE_SCLK	O	D	PD	Open	Reserved
53	RFFE_SDATA	IO	D	PD	Open	Reserved
54	GNSS_FREF_EN	I	D	PD	Open	Reserved
55	FEM_CTRL2	IO	D	PD	Open	Reserved
56	GNSS_FREF_OUT	O	D	-	Open	Reserved
57	SAR_VAIN1	IO	D	-	Open	Reserved
58	SAR_VAIN0	IO	D	-	Open	Reserved
59	FEM_CTRL3	IO	D	PD	Open	Reserved
60	ALARMZ	O	A	PU (100kΩ)	Open	Output indication signal for power state
61	RETLE_N_OUT	O	-	PD (10kΩ)	Open	Output indication signal for DDR retention state:

No.	Pin Name	Direction	Type	Reset Value	Recommendation for Unused pin	Description
62	VO3v15	O	P	-	-	3.15V power output, up to 100mA. This voltage shut down during hibernation.
63	EJTAG_TRST	I	D	PD	Open	Reserved
74	GND	-	-	-	-	Ground
75	GND	-	-	-	-	Ground
76	GPIO13/UART1_DTR	I	D	PD	Open	Reserved
77	GPIO15/UART1_RI	O	D	PD	Open	Reserved
78	GPIO16/UART1_DCD	O	D	PD	Open	Reserved
79	GPIO17/UART1_DSR	O	D	PD	Open	Reserved
80	UART1_CTS	I	D	PD	Open or Low	Clear to Send
81	UART1_RTS	O	D	PD	Open or Low	Ready to Send
82	UART1_RX	I	D	PU	-	Receiving Data
83	UART1_TX	O	D	PU	-	Transmitting Data
84	GND	-	-	-	-	Ground
85	GND	-	-	-	-	Ground
86	USB_Dp		A	-	-	USB2.0 Data positive
87	NC	-	-	-	Open	Not connected. It is better to solder.
88	USB_Dn		A	-	-	USB2.0 Data negative
89	GND	-	-	-	-	Ground
90	GND	-	-	-	-	Ground
91	GND	-	-	-	-	Ground
92	GPIO9/SPI_MEN_2	O	D	PD	Open	Reserved
93	GPIO6/SPI_S_CS	I	D	PU	Open	Reserved
94	GPIO4/SPI_S_MISO	O	D	PD	Open	Reserved
95	GPIO8/SPI_S_CLK	I	D	PD	Open	Reserved
96	GPIO5/SPI_S_MOSI	I	D	PD	Open	Reserved
97	SPI_MOSI	O	D	PU	Open	Reserved
98	SPI_CLK	O	D	PD	Open	Reserved
99	SPI_MEN_1	O	D	PD	Open	Reserved

No.	Pin Name	Direction	Type	Reset Value	Recommendation for Unused pin	Description
100	SPIM_MISO	I	D	PU	Open	Reserved
101	GPIO7/SPI_S_RDY	O	D	PD	Open	Reserved
102	TCK	I	D	PD	Open	Reserved
103	FEM_CTRL11	IO	D	PD	Open	Reserved
104	GND	-	-	-	-	Ground
105	GND	-	-	-	-	Ground
106	UART2_RX	I	D	PU	-	Receiving Data
107	UART2_TX	O	D	PU	-	Transmitting Data
108	GND	-	-	-	-	Ground
109	GND	-	-	-	-	Ground
120	VDDIO1v8_OUT	O	P	-	-	1.8V output, up to 50mA.
121	EXT_VREF	O	-	-	Open	external reference voltage input connected to internal LDO domain of 1160L
122	RSTN	I	-	PU (10kΩ)	Open	This pin is not used. Not connected.
123	SF_SI/IO0	IO	D	-	Open	Reserved
124	SF_CLK	O	D	PD	Open	Reserved
125	SF_n_HOLD/IO3	IO	D	PD	Open	Reserved
126	SF_nWP/IO2	IO	D	PD	Open	Reserved
127	SF_SO/IO1	IO	D	-	Open	Reserved
128	GPIO10/SF_n_CS2	O	D	PU	Open	Reserved
129	TDO	O	D	PU	Open	Reserved
130	TDI	I	D	PD	Open	Reserved
131	I2C_SCL	O	D	PU	Open	Reserved
132	2C_SDA	IO	D	PU	Open	Reserved
133	UIM_VCC	O	P	-	-	Output supply to SIM can be 1.8V
134	UIM_DATA	IO	D	PU	-	SIM IO
135	UIM_CLK	O	D	PU	-	SIM CLK
136	UIM_RESET	O	D	PU	-	SIM RST
137	UIM_DETECT	-	D	PD	Open	SIM card DETECT. Not assigned.
138	BOOST_EN		A	PD(100kΩ)	Open	Open drain output (Pch)
139	GND	-	-	-	-	Ground

No.	Pin Name	Direction	Type	Reset Value	Recommendation for Unused pin	Description
140	GND	-	-	-	-	Ground
141	WWAN_STAT E	O	D	PD	Open	Reserved
142	NC	-	-	-	Open	Not connected. It is better to solder.
143	WAKEUP_OUT/GPIO143	O	D	PD	Open	Output signal interrupt to wakeup HOST (GPIO143)
144	WAKEUP_IN/GPIO144	I	D	PD	PD	Input signal to wakeup modem. Must keep stable and valid:
145	RESET	I	D	PU(100 kΩ)-	Open	HW_RESET
146	VREF	O	P	-		Reference Logic Voltage. 1.8V output up to 50 mA. This voltage is always on.
G1	GND	-	-	-	-	Ground
G2	GND	-	-	-	-	Ground
G3	GND	-	-	-	-	Ground
G4	GND	-	-	-	-	Ground
G5	GND	-	-	-	-	Ground
G6	GND	-	-	-	-	Ground
G7	GND	-	-	-	-	Ground
G8	GND	-	-	-	-	Ground
G9	GND	-	-	-	-	Ground
G10	GND	-	-	-	-	Ground
G11	GND	-	-	-	-	Ground
G12	GND	-	-	-	-	Ground
G13	GND	-	-	-	-	Ground
G14	GND	-	-	-	-	Ground
G15	GND	-	-	-	-	Ground
G16	GND	-	-	-	-	Ground
G17	GND	-	-	-	-	Ground
G18	GND	-	-	-	-	Ground
G19	GND	-	-	-	-	Ground
G20	GND	-	-	-	-	Ground
DG1	GND	-	-	-	-	Ground
DG2	GND	-	-	-	-	Ground
DG3	GND	-	-	-	-	Ground

No.	Pin Name	Direction	Type	Reset Value	Recommendation for Unused pin	Description
DG4	GND	-	-	-	-	Ground
DG5	GND	-	-	-	-	Ground
DG6	GND	-	-	-	-	Ground
DG7	GND	-	-	-	-	Ground
DG8	GND	-	-	-	-	Ground
DG9	GND	-	-	-	-	Ground
DG10	GND	-	-	-	-	Ground
DG11	GND	-	-	-	-	Ground
DG12	GND	-	-	-	-	Ground
DG13	GND	-	-	-	-	Ground
DG14	GND	-	-	-	-	Ground
DG15	GND	-	-	-	-	Ground
DG16	GND	-	-	-	-	Ground
DG17	GND	-	-	-	-	Ground
DG18	GND	-	-	-	-	Ground
DG19	GND	-	-	-	-	Ground
DG20	GND	-	-	-	-	Ground
DG21	GND	-	-	-	-	Ground
DG22	GND	-	-	-	-	Ground
DG23	GND	-	-	-	-	Ground
DG24	GND	-	-	-	-	Ground
DG25	GND	-	-	-	-	Ground
DBG1	GND	-	-	-	-	Ground
DBG2	GND	-	-	-	-	Ground
DBG3	GND	-	-	-	-	Ground
DBG4	GND	-	-	-	-	Ground
DBG5	GND	-	-	-	-	Ground
DBG6	GND	-	-	-	-	Ground
DBG7	GND	-	-	-	-	Ground
DBG8	GND	-	-	-	-	Ground
DBG9	GND	-	-	-	-	Ground
DBG10	GND	-	-	-	-	Ground
DBG11	GND	-	-	-	-	Ground
DBG12	GND	-	-	-	-	Ground
DBG13	GND	-	-	-	-	Ground

No.	Pin Name	Direction	Type	Reset Value	Recommendation for Unused pin	Description
DBG14	GND	-	-		-	Ground
DBG15	GND	-	-		-	Ground
DBG16	GND	-	-		-	Ground
DBG17	GND	-	-		-	Ground
DBG18	GND	-	-		-	Ground

**NOTE**

- **I**: Input only functionality. **O**: Output only functionality.  
**IO**: Both input and output functionality.
- **A**: Analog pin. **D**: Digital pin. **PD**: Pull Down. **PU**: Pull Up. **P**: Power.
- Connected to a common ground plane.

## 3.2. Power Management Unit (PMU)

### 3.2.1. Overview

ALT1160L contains a PMU unit that is responsible for the power supply of all the different voltage needed for the ALT1160L functional behavior and the functionality of a neighbor chip (The RFIC can get power supplies from the ALT1160L). The PMU is an integration of an external PMIC into the IC.

The power supply part of the module contains:

- RTC (Real Time Clock)
- APC (Advance Power Controller)
- different regulators (LDOs and DC-DC)

**Table3 lists the definitions of the pins on the power supply interface**

Pin No.	Signal Name	I/O	Description	voltage (V)
37	VCC1	I	VBAT_L Module input power supply for internal 1.8V DC-DC.	2.3 - 4.2
38	VCC2	I		
39	VCC3	I	VBAT_H Module input power supply for 1160L PMU and PA DC-DC.	3.4 - 4.2
40	VCC4	I		
41	VCC5	I		
42	VCC6	I		
62	V0315	O	3.15V output, up to 100mA.	3.15
133	UIM_VCC	O	Output supply to SIM can be 1.8V configurable by software.	1.8
146	VREF	O	1.8V output to 50mA. This voltage is always on.	1.8

### 3.2.2. USIM Power Output UIM\_VCC

Through the UIM\_VCC power supply interface, 1.8V power from the module can be supplied to UIM card.

Special attention should be taken on PCB design at the host side.

### 3.3. Signal Control Interface

#### 3.3.1. Overview

The signal control part of the interface in the module contains the following:

- RESET pin
- WAKEUP\_OUT pin
- WAKEUP\_IN pin
- RSTN pin
- BOOST\_EN pin
- ALARMZ pin
- RETLE\_N\_OUT pin

**Table4 Pins on the signal control interface**

Pin No.	PIN Name	I/O	Description
145	RESET	I	Reset input signal to the module, has internal PU to 1.8V. Must keep stable and valid.
143	WAKEUP_OUT	O	Output signal interrupt to wakeup HOST.
144	WAKEUP_IN	I	Input signal to wakeup modem. Must keep stable and valid. 0V = modem can enter Hibernation
122	RSTN	I	Reset input signal. The pin is not used. Not connected.
138	BOOST_EN		Open drain output (Pch)
60	ALARMZ		Output indication signal for power state.
61	RETLE_N_OUT	O	Output indication signal for Hibernation.



### 3.3.2. RESET Pin

Reset input signal to the module, has internal PU to 1.8V.

Pulling RESET low more than 100ms and then pulling high will reset the module.

### 3.3.3. WAKEUP\_OUT Pin

**Table5 Two States of WAKEUP\_OUT**

Item	Pin state	Description
1	High	Interrupt to wakeup HOST. Module wants to send data to host.
2	Low	No interrupt. May require using external pull down resistors if connected to the host.

### 3.3.4. WAKEUP\_IN Pin

Input signal to WAKEUP\_IN must keep stable and valid.

**Table6 Two states of WAKEUP\_IN**

Item	Pin state	Description
1	High	Wakeup the module or keep active. Module won't enter Hibernation if this signal kept high. The pin is related to BOOST_EN pin.
2	Low	Change the state of module Active to Hibernation.

### 3.3.5. RSTN Pin

The pin is not used because it resets only the baseband chipset, not the module.

The pin should be opened.

### 3.3.6. ALARMZ Pin

Output indication signal for power state.

**Table7 Two states of ALARMZ**

Item	Pin state	Description
1	High	Hibernation
2	Low	Active

### 3.3.7. RETLE\_N\_OUT Pin

Output indication signal for Hibernation.

**Table8 Two states of RETLE\_N\_OUT**

Item	Pin state	Description
1	High	Active
2	Low	Hibernation

## 3.4. USB Interface

The module is compliant with USB2.0 high speed protocol. The USB input/output lines are following USB2.0 specifications. (Maximum 480Mbps.)

It is for debug.

**Table9 List of USB pins**

Pin No.	Pin Name	Description
86	USB_Dp	USB2.0 Data positive
88	USB_Dn	USB2.0 Data negative

### 3.5. UART Interface

The module includes a 4-wire (UART1) and 2-wire (UART2) UART interface.

UART interface is available for the communication with a host application processor (AT commands, data communication etc.). The UART is an asynchronous serial interface and UART1 is maximum baud rate of 3M Baud.

The baud rate can only be changed via AT command. (Refer to Software Application Guide)

Default setting is following:

Baud rate: 115200, Data: 8bit, Parity: none, Stop: 1bit, Flow control: none

#### NOTE

- If host will use UART1, it should set WAKEUP\_IN to high.

**Table10 List of UART1 pins**

No.	Pin Name	I/O	Description
80	UART1_CTS	I	Clear to Send.
81	UART1_RTS	O	Ready to Send.
82	UART1_Rx	I	Receiving Data.
83	UART1_Tx	O	Transmitting Data.

**Table11 List of UART2 pins**

No.	Pin Name	I/O	Description
106	UART2_Rx	I	Receiving Data.
107	UART1_Tx	O	Transmitting Data.

## 3.6. USIM Card Interface

### 3.6.1. Overview

This device supports the usage and control (including powering) of an external USIM.

The module supports Class C (1.8V).

To achieve ultra-low power consumption, SIM power will be off during Hibernation.

The USIM input/output lines are following USIM specifications.

### 3.6.2. Circuit Recommended for the USIM Card Interface

As the module is not equipped with an USIM card adapter, you need to place an USIM card adapter on the user interface board.

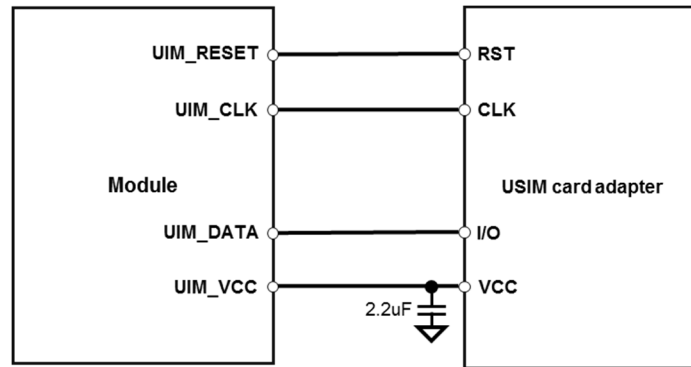

Figure3 Connections of the USIM card interface

## 3.7. RF Antenna Interface

### 3.7.1. RF Connector location

This module does not include any antennas. External antennas need to be used for the final products using this module.

#### NOTE

- You should prepare an external antenna which was certified based on the Radio Type Approval of the module.
- Please optimize impedance matching between RF input/output line and antenna by using a matching circuit.  
The RF input/output line of characteristic impedance in the module is 50Ω.
- In order to diversity received, two antennas are required. (main antenna, sub antenna)
- One antenna (main antenna) can be used, but the reception sensitivity of Rx gets worse.  
If only main antenna is used, the terminal of sub antenna is terminated with 50Ω.
- Do not connect two antenna terminals together in one antenna.

## 4. RF Specifications

### 4.1. Operating Frequencies

Table12 shows the RF bands supported by the module

Operating Band	TX	RX	Bandwidth
Band1	1940MHz–1960MHz	2130MHz–2150MHz	5MHz/ 10MHz/ 15MHz
Band19	830MHz–845MHz	875MHz–890MHz	5MHz/ 10MHz

\* For use in japan only.

### 4.2. Test Standards

The module meets 3GPP TS 36.521-1 test standards. The module passes strict tests at the factory and thus the quality of the module is guaranteed.

### 4.3. RF Specifications

- "Test Value" in the table is the average value of the sample.
- The test values are offset in evaluation board pattern loss.  
Therefore, they are treated as the value of the electrode pad.
- conducted condition

Table13 RF Specifications (Band1)

Parameter	Condition	Min.	Max.	Unit
Maximum Output Power		20.3	25.7	dBm
Rx Sensitivity	Throughput > 95%	-97	-	dBm

Table14 RF Specifications (Band19)

Parameter	Condition	Min.	Max.	Unit
Maximum Output Power		20.3	25.7	dBm
Rx Sensitivity	Throughput > 95%	-97	-	dBm

## 5. Electrical Specifications

### 5.1. Absolute Maximum Ratings

#### WARNING

Table15 lists the absolute ratings for the module. Using the module beyond these conditions may result in permanent damage to the module.

**Table15 Absolute maximum ratings for the module**

Symbol	Parameter	Min.	Max.	Unit
VBAT_H	VBAT_H supply pin	-0.3	5.5	V
VBAT_L	VBAT_L supply pin	-0.3	6.0	V
VDDIO	Voltage on any non-power-supply pin	-0.3	3.6	V

#### NOTE

- Since the voltage input to VBAT\_L might be input also to the DC-DC for VBAT\_H, consider the absolute maximum rating of the DC-DC.

### 5.2. Operating Conditions

**Table16 Operating conditions**

Parameter	Min.	Typ.	Max.	Unit	Description
Operating temperatures	-10	-	+55	°C	-
Storage temperatures	-40	-	+80	°C	-
Module Vin (VBAT_H)	3.4	3.4	4.2	V	-
Module Vin (VBAT_L)	2.3	3.0	4.2	V	-

**Table17 DC Characteristics of GPIO pin**

Parameter	Min.	Typ.	Max.	Unit
V <sub>IH</sub>	0.85 * VDDIO	-	VDDIO + 0.3	V
V <sub>IL</sub>	-0.3	-	0.25 * VDDIO	V
V <sub>OH</sub>	1.6	-	VDDIO	V
V <sub>OL</sub>	0	-	0.45	V
VDDIO	1.76	1.8	1.84	V

## 5.3. Power Supply

### 5.3.1. Input Power Supply

**Table18** Requirements for input power of the module

Parameter	Min.	Max.	Ripple Max.	Unit
VBAT_L	2.3	4.2	0.1	V
VBAT_H	3.4	4.2	0.2	V

**Table19** Requirements for input current of the module

Power	Peak(Maximum)
VBAT_L	300mA
VBAT_H	2000mA

#### NOTE

- Power voltage of our evaluation board is as follows;  
 VBAT\_L: 3.0V, VBAT\_H: 3.4V

### 5.3.2. Power Consumption

Module is optimized to achieve ultra-low power consumption addressing IoT market needs. Power state is supported. (See the following Table27)

**Table20** Power state

Power state	Description	Required supplies
Shutdown	Module powered off.	-
Hibernation	System is halted..	-
Active	All system is wakeup.	All required power supplies are available.

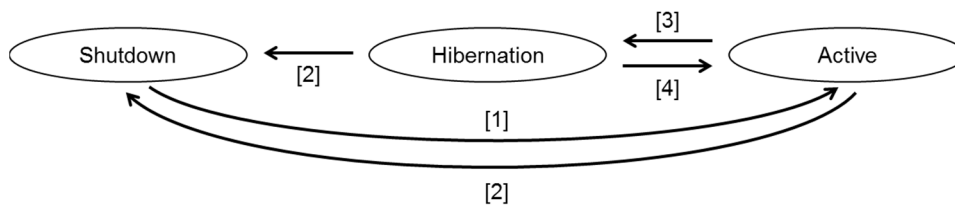

**Figure4** power state transition diagram



### 5.3.3. Power Consumption

[conditions]

- measured on our evaluation board at 25°C indoor
- Band: 1, Band Width: 10MHz
- DRX cycle = 1.28 s
- eDRX cycle = 81.92s, PTW = 1.28 s

**Table21 Averaged power consumption of the evaluation board**

Mode	Typical values (Avg)	Condition
Tx Power @23dBm	700mA	-
DRX	2.9mA	SIM power on
eDRX	99uA	Average power consumption for 1 hour after shift to eDRX.

## 6. Function and Features

### 6.1. Power on/off

#### 6.1.1. Power on

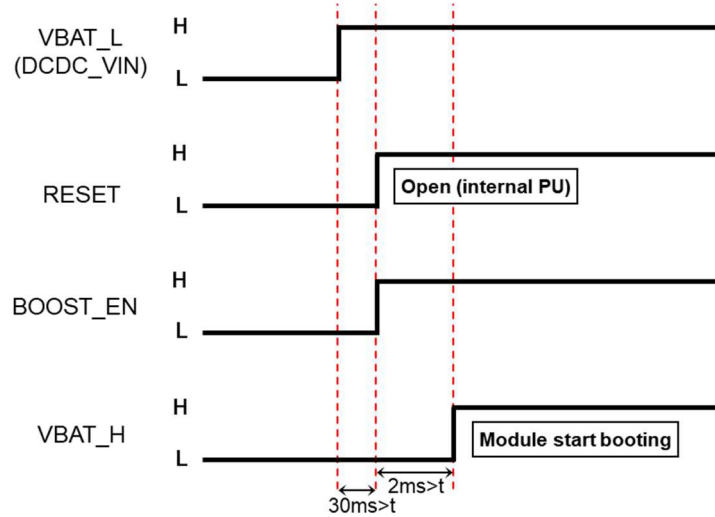

Figure5 Power on sequence (triggered by VBAT\_L)

#### 6.1.2. Power off

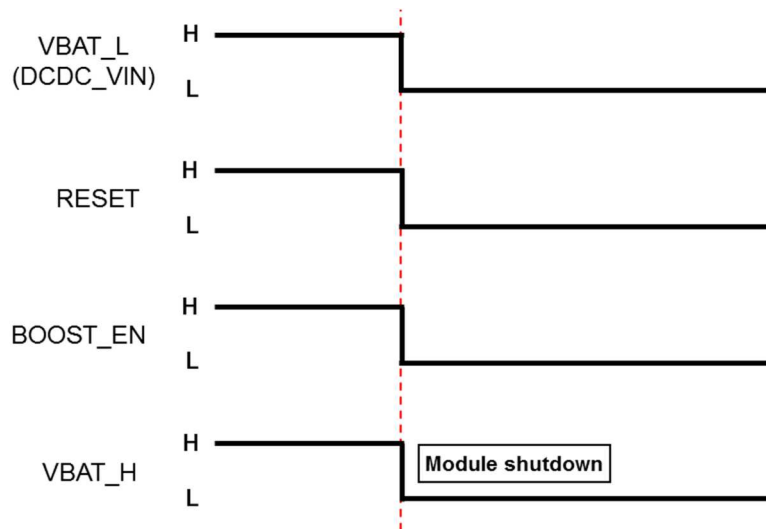
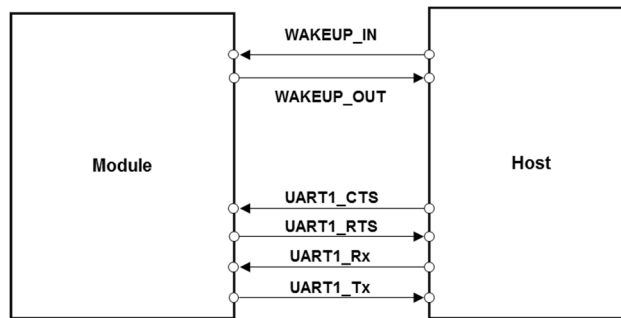

Figure 6 Power off sequence (triggered by VBAT\_L)

## 6.2. Host-Module Mutual Wakeup Interface for UART



**Figure7 Host-Module Mutual Wakeup**

The state of WAKEUP\_IN and WAKEUP\_OUT

(1) WAKEUP\_IN (Host: Output, Module: Input)

High : When host need to open the data interface and to wake up to module.

Low : When host need to close the data interface.

(2) WAKEUP\_OUT (Host: Input, Module: Output)

High : Module need to open the data interface.

Therefore, interrupt to wakeup host.

Low : Module do not need to open the data interface.

## 7. Mechanical Specifications

### 7.1. Dimensions of the module

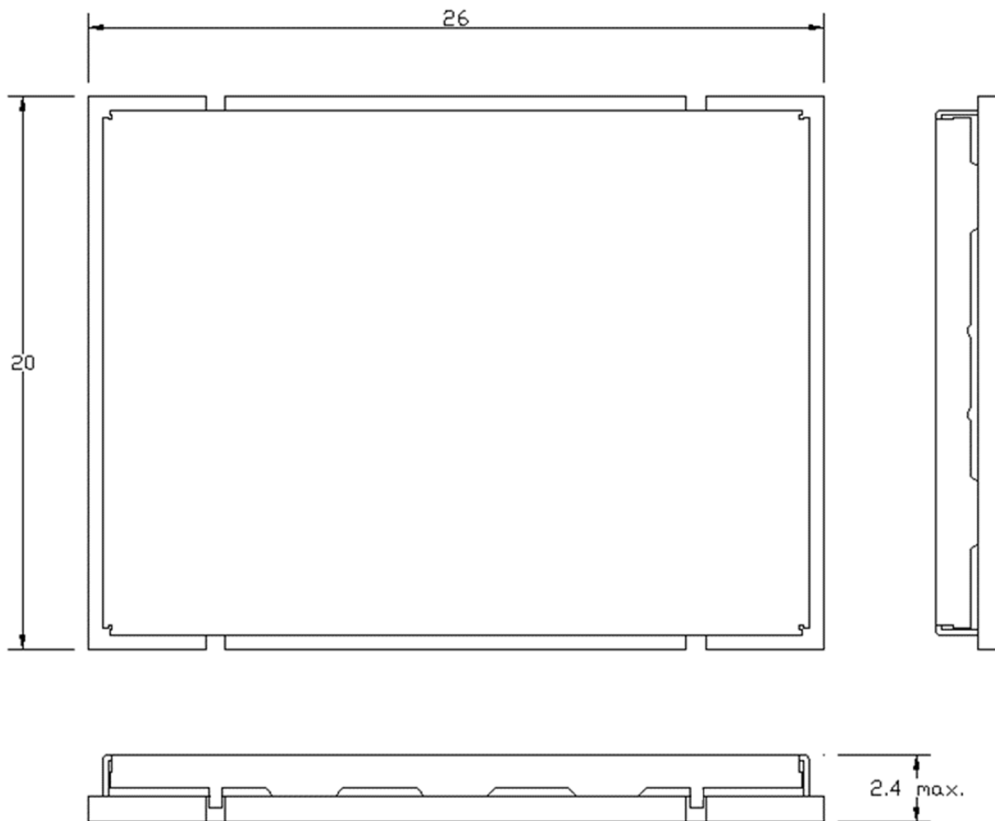

**Figure8 Dimensions of the module (TOP VIEW) (unit: mm)**

\*Tolerances unless otherwise specified:  $\pm 0.2\text{mm}$

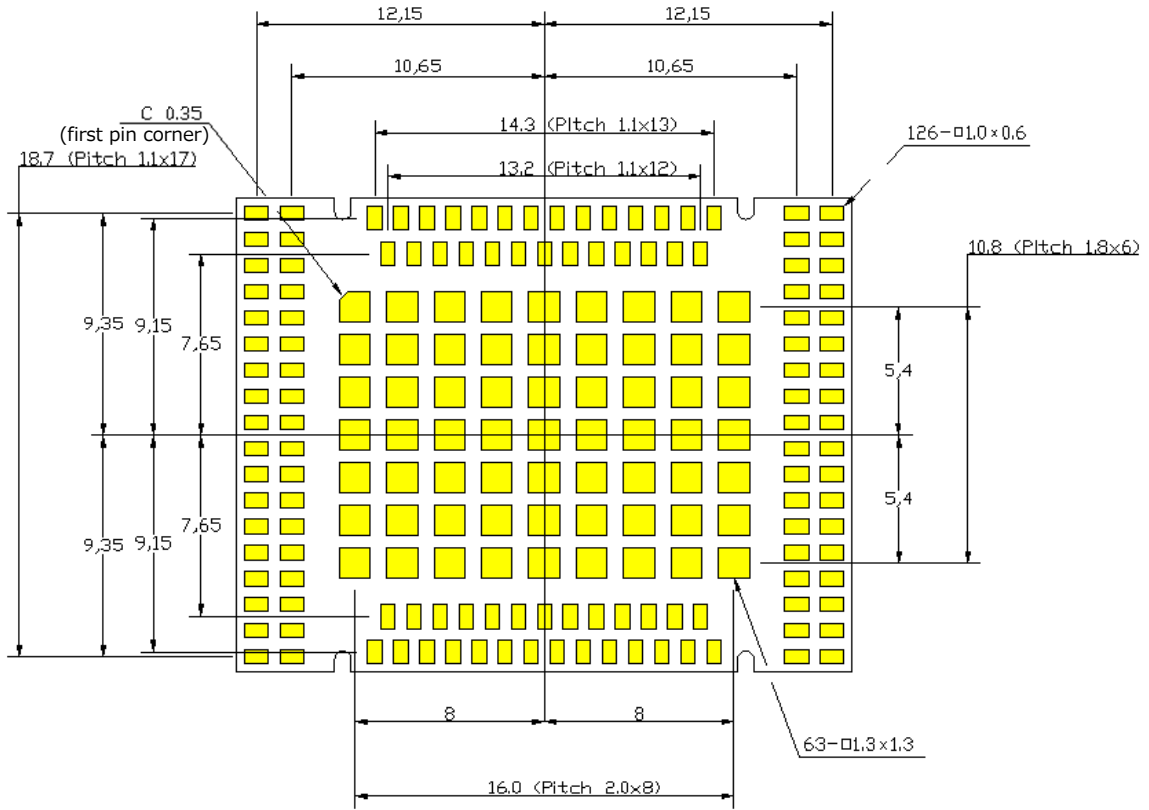

Figure9 Dimensions of the module (TOP THRU VIEW) (unit: mm)

## 7.2. Label

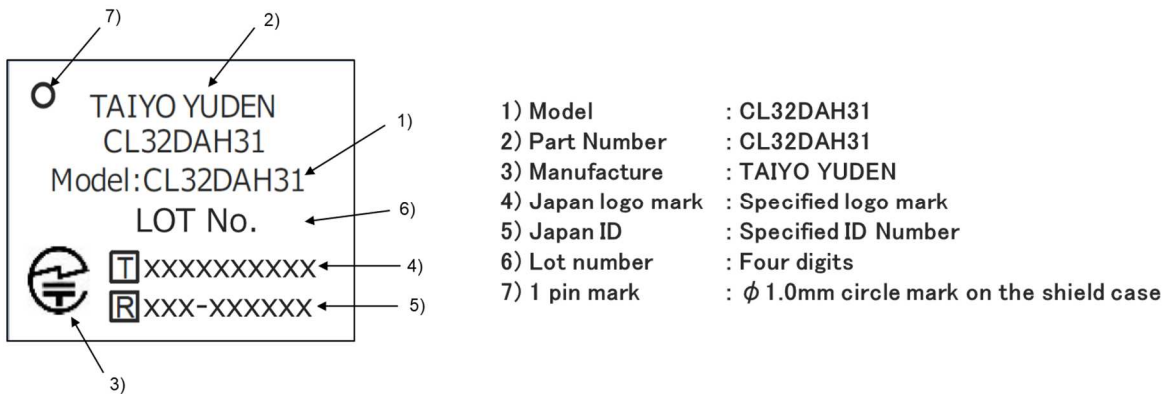

Figure10 Description of label

### 7.3. Packing System

The module package includes the tray, tray (cover), antistatic band, desiccant, and humidity indicator card.

This module is stored in the tray.

- Packaging method: Tray
  - \* It might be providing as tray at sample stage.

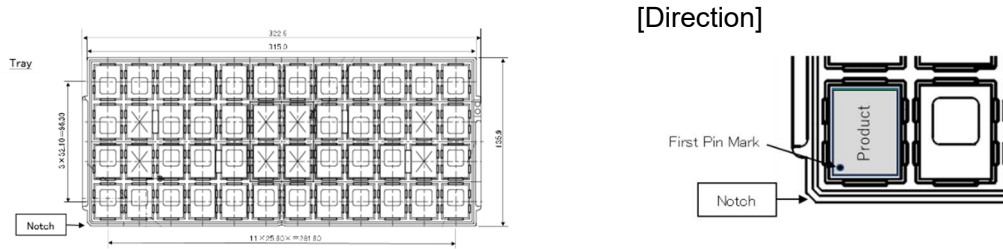

Figure11 Packaging Figure

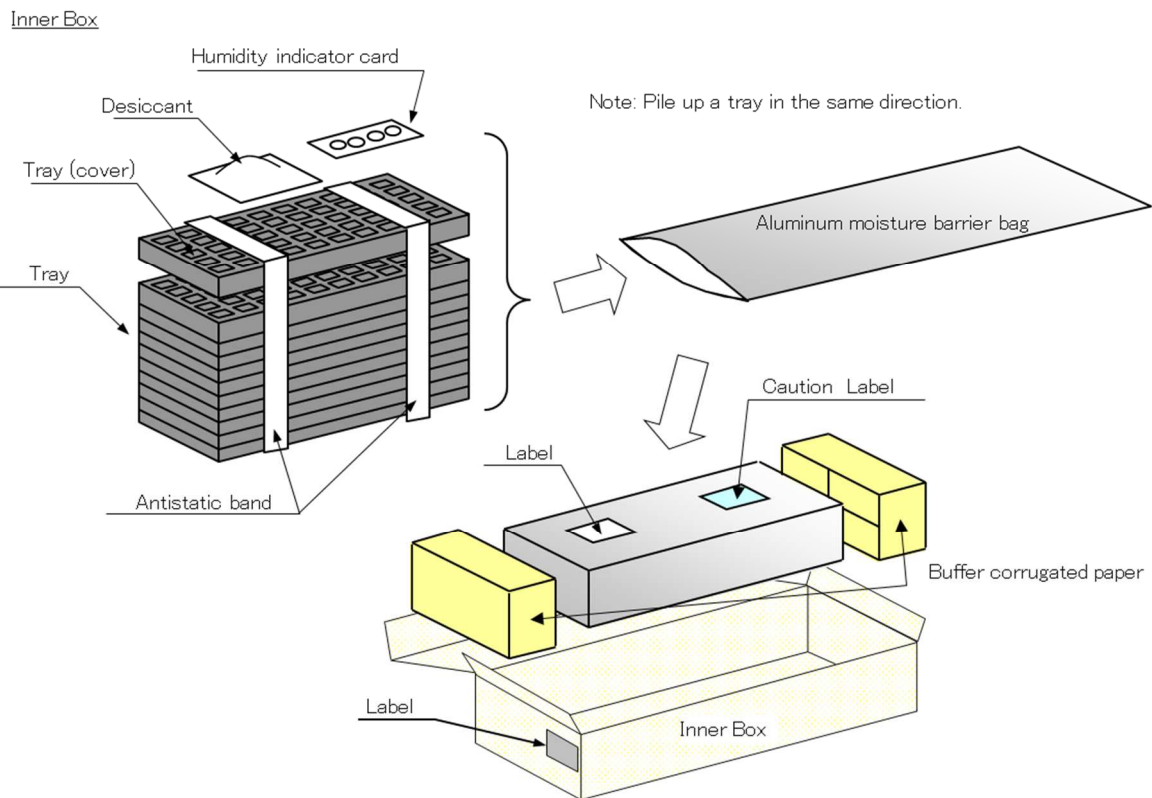

Figure12 Package assembly

## 8. Handling Precautions

### 8.1. Thermal Management

CL32DAH31 have high power consumption and due to their very small size, need to be designed properly for heat dissipation

### 8.2. Desire and Conditions

This specification describes desire and conditions especially for mounting.

#### 8.2.1. Environment conditions for use and storage

1. Store the components in an environment of  $< 40^{\circ}\text{C} / 90\%\text{RH}$  if they are in a moisture barrier bag packed by TAIYO YUDEN.
2. Keep the factory ambient conditions at  $< 30^{\circ}\text{C} / 60\%\text{RH}$ .
3. Store the components in an environment of  $< 25 \pm 5^{\circ}\text{C} / 10\%\text{RH}$  after the bag is opened.  
(The condition is also applied to a stay in the manufacture process).

#### 8.2.2. Conditions for handling of products

Make sure all of the moisture barrier bags have no holes, cracks or damages at receiving. If an abnormality is found on the bag, its moisture level must be checked in accordance with 2 of 8.2.2.

Refer to the label on the bag.

1. All of the surface mounting process (reflow process) must be completed in 12 months from the bag sea date.
2. Make sure humidity in the bag is less than 10%RH immediately after open, using a humidity indicator card sealed with the components.
3. All of the surface mounting process (reflow process including rework process) must be completed in 168 hours after the bag is opened (inclusive of any other processes).
4. If any conditions in 8.2.1. or condition 2 and 3 of 8.2.2. are not met, bake the components in accordance with the conditions at  $125^{\circ}\text{C}$  24h.
5. As a rule, baking the components in accordance with conditions 4 of 8.2.2. shall be once.
6. Since semi-conductors are inside of the components, they must be free from static electricity while handled. ( $< 100\text{V}$ ) Use ESD protective floor mats, wrist straps, ESD protective footwear, air ionizers etc., if necessary.
7. Please make sure that there are lessen mechanical vibration and shock for this module, and do not drop it.
8. Please recognize pads of back side at surface mount.
9. This module should not be cleaned.
10. Please perform temperature conditions of module at reflow within the limits of the following.

Please give the number of times of reflow as a maximum of 2 times.

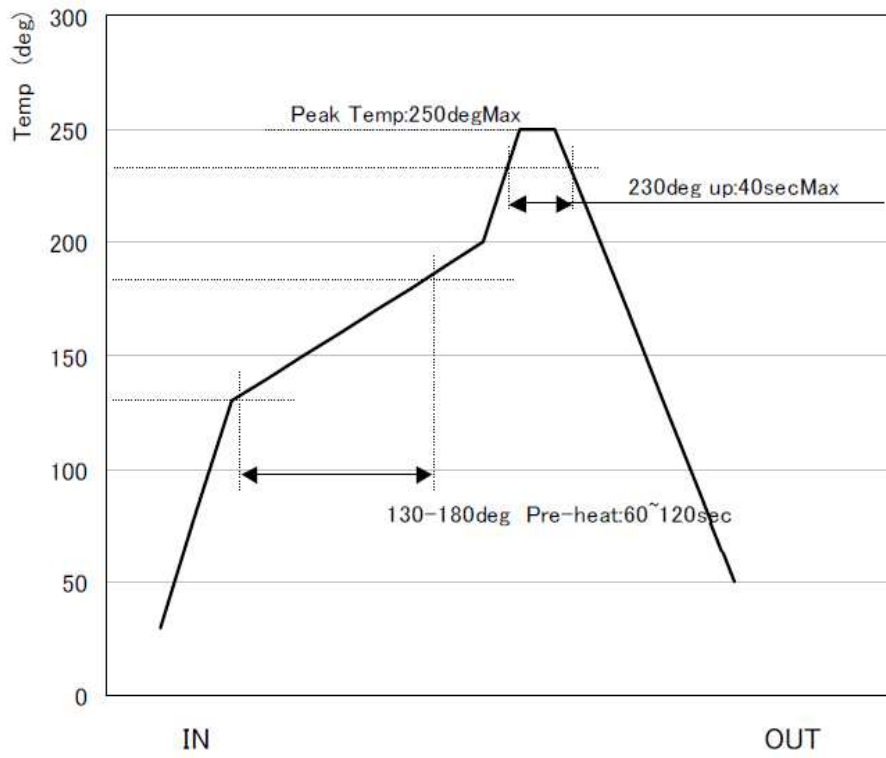

Figure13 temperature conditions of module at reflow



## 9. Certifications

### 9.1. Certifications

**NOTE**

- Table22 shows the certificate obtained by the module.

**Table22 Product certifications**

Certification	Model Name
	CL32DAH31
technical regulations conformity certification of the Radio law	✓
Japan Approvals institute for Telecommunications Equipment	✓
Carrier IOT (docomo)	✓

## 10. Safety Information

Read the safety information carefully to ensure the correct and safe use of module.  
Applicable safety information must be observed.

### 10.1. Interference

Communication between this product and other might not be established nor maintained depending upon radio environment or operating condition of this product and other products with wireless technology.

This product operates in the licensed band at 2GHz/800MHz. In case this product is used around the other wireless devices which operate in same frequency band of this product, there is a possibility that interference occurs between this product and such other devices. If such interference occurs, please stop the operation of other devices or relocate this product before using this product or do not use this product around the other wireless devices. Power off module if using the device is prohibited. Do not use the module when it causes danger or interference with electric devices.

### 10.2. Medical Device

- Power off module and follow the rules and regulations set forth by the hospitals and health care facilities.
- Some module may affect the performance of the hearing aids. For any such problems, consult your service provider.
- Pacemaker manufacturers recommend that a minimum distance of 15 cm be maintained between the module and a pacemaker to prevent potential interference with the pacemaker. If you are using an electronic medical device, consult the doctor or device manufacturer to confirm whether the radio wave affects the operation of this module.

### 10.3. Area with Inflammables and Explosives

To prevent explosions and fires in areas that are stored with inflammable and explosive devices, power off module and observe the rules. Areas stored with inflammables and explosives include but are not limited to the following:

- Gas station
- Fuel depot (such as the bunk below the deck of a ship)
- Container/Vehicle for storing or transporting fuels or chemical products
- Area where the air contains chemical substances and particles (such as granule, dust, or metal powder)
- Area indicated with the "Explosives" sign
- Area indicated with the "Power off bi-direction wireless equipment" sign
- Area where you are generally suggested to stop the engine of a vehicle

#### **10.4. Airline Security**

Observe the rules and regulations of airline companies. When boarding or approaching a plane, power off module. Otherwise, the radio signal of the module may interfere with the plane control signals.

#### **10.5. Safety of Children**

Do not allow children to use the module without guidance. Small and sharp components of the module may cause danger to children or cause suffocation if children swallow the components.

#### **10.6. Environment Protection**

Observe the local regulations regarding the disposal of your packaging materials, used module, and promote their recycling.

#### **10.7. RoHS Approval**

The module is in compliance with the restriction of the use of certain hazardous substances in electrical and electronic equipment Directive 2011/65/EU (RoHS Directive).

#### **10.8. Laws and Regulations Observance**

Observe laws and regulations when using module. Respect the privacy and legal rights of the others.

#### **10.9. Care and Maintenance**

It is normal that module gets hot when you use or charge it. Before you clean or maintain the module, stop all applications and power off the module.

- Use module with care and in clean environment. Keep the module from a fire or a lit cigarette.
- Protect module from water and vapor and keep it dry.
- Do not drop, throw or bend module.
- Clean module with a piece of damp and soft antistatic cloth. Do not use any chemical agents (such as alcohol and benzene), chemical detergent, or powder to clean it.
- Do not leave module in a place with a considerably low or high temperature.
- Do not dismantle the module. Otherwise, the module is not covered by the warranty.

#### **10.10. Emergency Call**

This module functions through receiving and transmitting radio signals.

Therefore, the connection cannot be guaranteed in all conditions. In an emergency, module cannot be used.

## Appendix. Acronyms and Abbreviations

Term	Definition
DC	Direct Current
DRX	Discontinuous Reception
eDRX	Extended DRX
EJTAG	Embedded Joint Test Action Group
EU	European Union
EUTRA	Evolved Universal Terrestrial Radio Access
FDD	Frequency Division Duplex
GNSS	Global Navigation Satellite System
GPIO	General Purpose Input Output
IMS	IP Multimedia Subsystem
LGA	Land Grid Array
LTE	Long Term Evolution
MCP	Multi-chip Package
MISO	Multiple In Single Out
NC	Not Connected
OFDMA	Orthogonal Frequency Division Multiple Access
PCB	Printed Circuit Board
PCM	Pulse Code Modulation
PDU	Protocol Data Unit
PMU	Power Management Unit
RF	Radio Frequency
RoHS	Restriction of the Use of Certain Hazardous Substances
RTC	Real Time Clock
RX	Receive
SC-FDMA	Single-Carrier Frequency Division Multiple Access
SMS	Short Message Service
SPI	Serial Peripheral Interface
TX	Transmit
UART	Universal Asynchronous Receiver Transmitter
USB	Universal Serial Bus
USIM	Universal Subscriber Identity Module
UTRA	Universal Terrestrial Radio Access