

EVALUATION BOARD MANUAL EC2832AA2-EVB

EVALUATION KIT MANUAL EC2832AA2-EVK

for EC2832 series Bluetooth[®] low energy Module

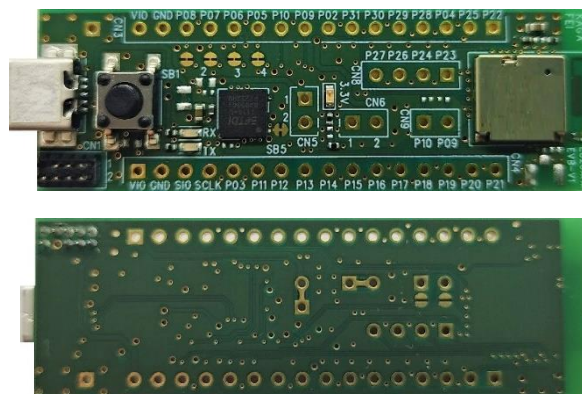

Contents

1. Introduction	3
2. Mounted module	3
3. Content	4
4. Evaluation board circuit schematic.....	4
5. Evaluation board layout	5
6. Silkscreen Printing	5
7. Pin Descriptions.....	6
8. How to use.....	6
9. For software development	7
10. MEMO.....	8

1. Introduction

This evaluation board is applicable for KAGA FEI's **Bluetooth® low energy** module, EC2832 Series.

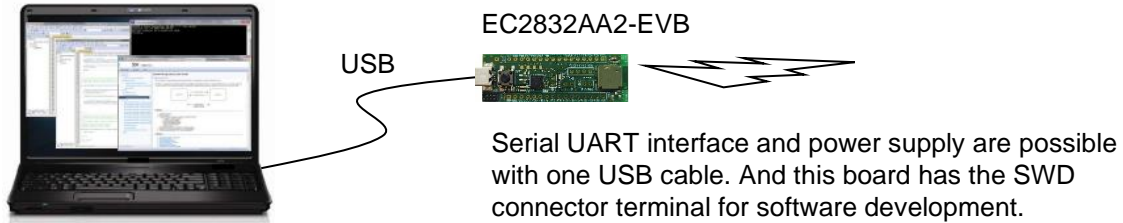

2. Mounted module

EC2832 (9.6mm x 12.9mm x 2.0mm_MAX)



Nordic nRF52832 / ARM® Cortex™-M4F 32 bit processor
47-pin Land Grid Array / 30GPIOs / SWD

- Basic Module –
KAGA FEI writes S132 SoftDevice to this product (EC2832AA2).
The user can develop unique application for the module.

3. Content

1	EC2832AA2-EVB Evaluation Board + USB cable for Evaluation Board	1 pc
2	J-Link Lite (EC2832AA2-EVK Only) + USB cable for Evaluation Board *1	1 set

1. EC2832AA2-EVB

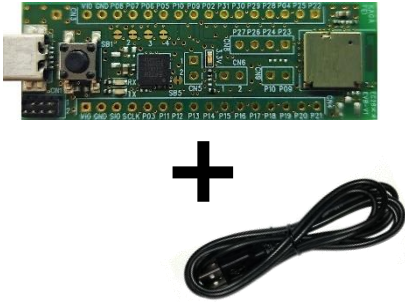

2. EC2832AA2-EVK



*1 Notes on using J-Link Lite

J-Link Lite is only delivered and supported as part of an evaluation kit, which includes an evaluation board. It may only be used with the evaluation board it came with, and not to be used for commercial product development.

4. Evaluation board circuit schematic

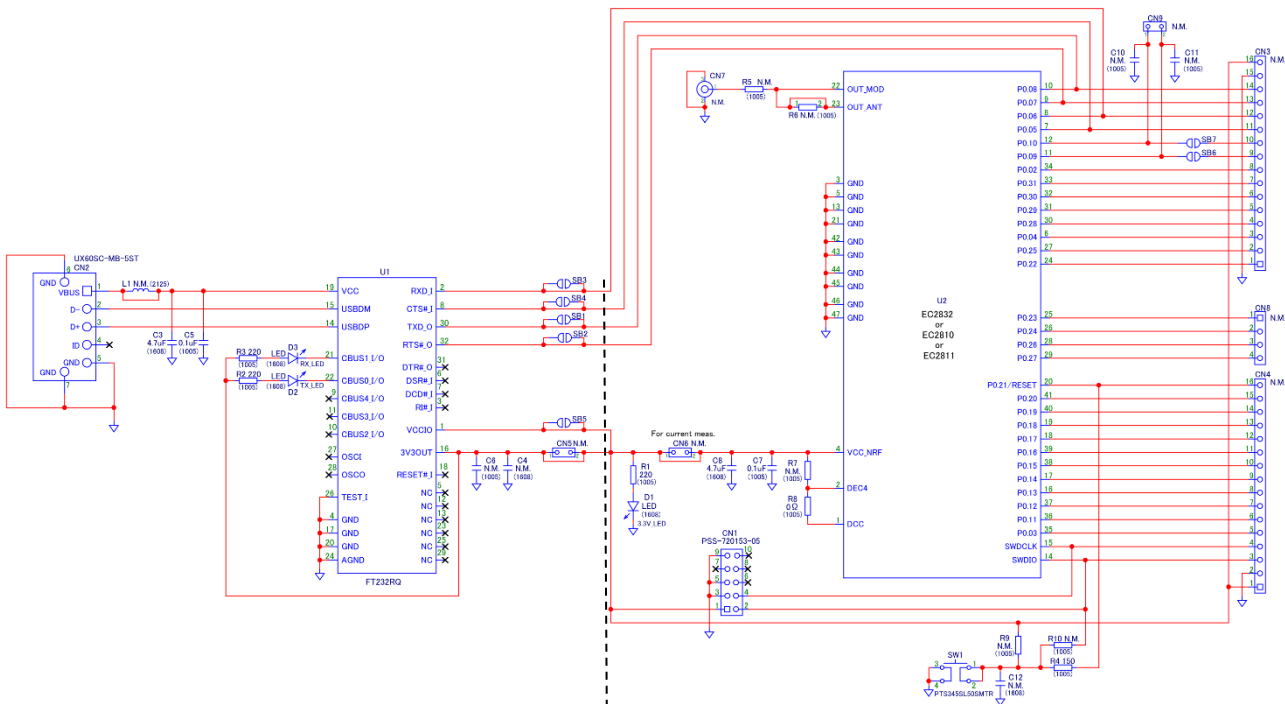

Please cut these 6 lines on the board if you want to separate U1 and U2.

5. Evaluation board layout

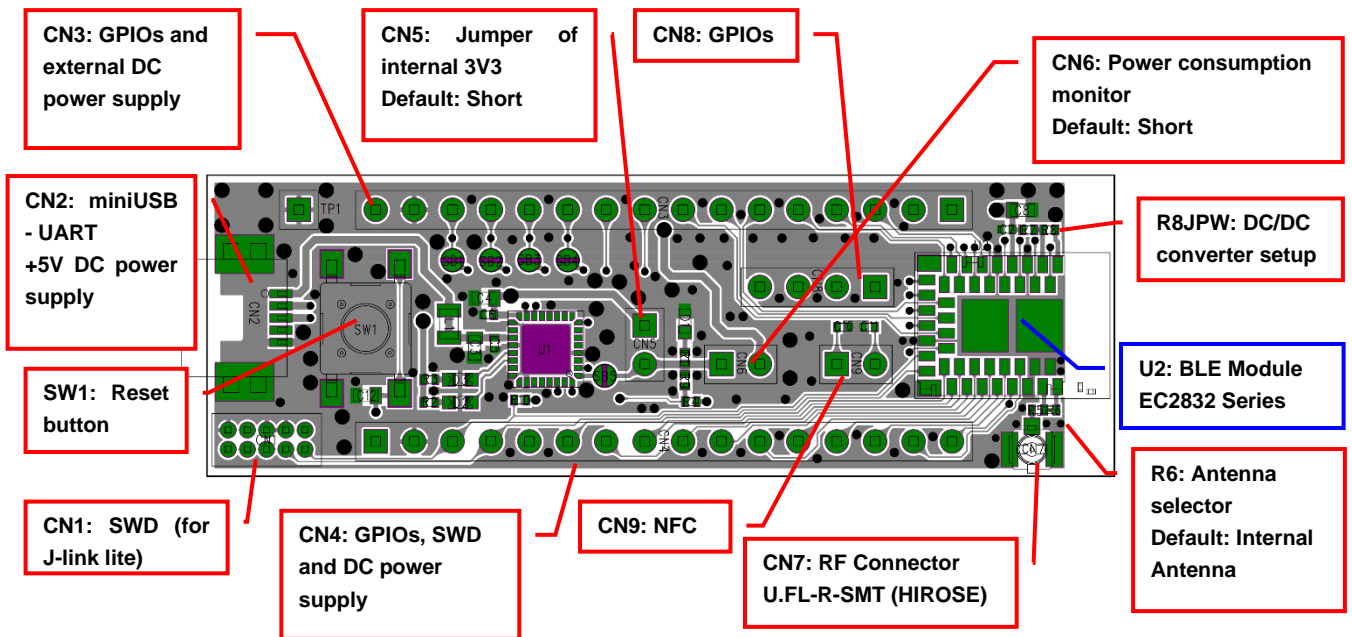

- 1) All pin headers are 2.54mm pitch. And distance between **CN3** and **CN4** is **15.24mm**.
- 2) **CN3,4,5,6,8, C4,6,10-12, L1, R5-7,9,10, SB1-7, TP1** are not mounted (N.M.).
- 3) **D1 (LED):** 3.3V Indicator
- 4) **D2 (LED):** UART TX Indicator
- 5) **D3 (LED):** UART RX Indicator
- 6) **SW1 (Push button):** Module Reset (active low)

6. Silkscreen Printing

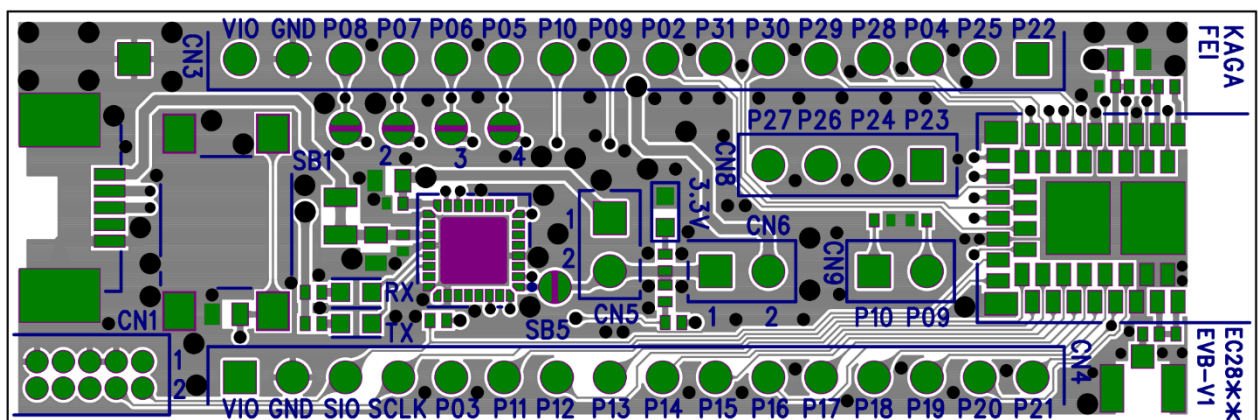

7.Pin Descriptions

Pin No.	CN3	CN4	CN8
1	P0.22	VIO	P0.23
2	P0.25	GND	P0.24
3	P0.04	SWDIO	P0.26
4	P0.28	SWDCLK	P0.27
5	P0.29	P0.03	-
6	P0.30	P0.11	-
7	P0.31	P0.12	-
8	P0.02	P0.13	-
9	NFC/P0.09	P0.14	-
10	NFC/P0.10	P0.15	-
11	P0.05	P0.16	-
12	P0.06	P0.17	-
13	P0.07	P0.18	-
14	P0.08	P0.19	-
15	GND	P0.20	-
16	VIO	P0.21/RESET	-

8.How to use

It is very easy just to tie this board to the PC with a USB cable. It is not necessary to change the setting of the board. The power supply of the module supplies by default 3.3V from 3V3OUT of FT232RQ.

9. For software development

- Nordic-DK and Use case



Nordic nRF Connect etc.



NORDIC DK

EC2832AA2-EVB

miniUSB

SWD



- SEGGER Embedded Studio



- Visual Studio Code

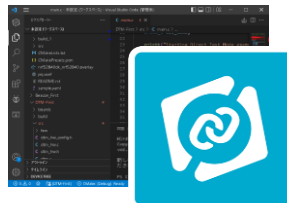

SWD : Serial Wire Debug
It can be use J-Link Lite CortexM-9 JTAG/SWD Emulator that attached with EC2832AA2-EVK.



CN1 supports the connection of the 10 pin 1.27 mm flat cable.

- nRF Connect for Desktop

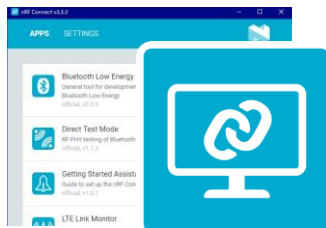

etc.

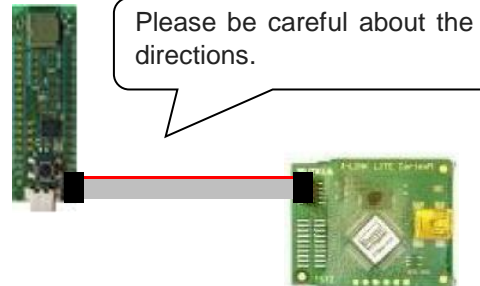

- Nordic-DK

<https://www.nordicsemi.com/Products/Development-hardware/nrf52-dk>



10.MEMO

1) Current measurement

To measure the current, please cut the shorting 1pin and 2 pin of CN6. And connect an ampere-meter between the pins of connector CN6 to monitor the current directly.

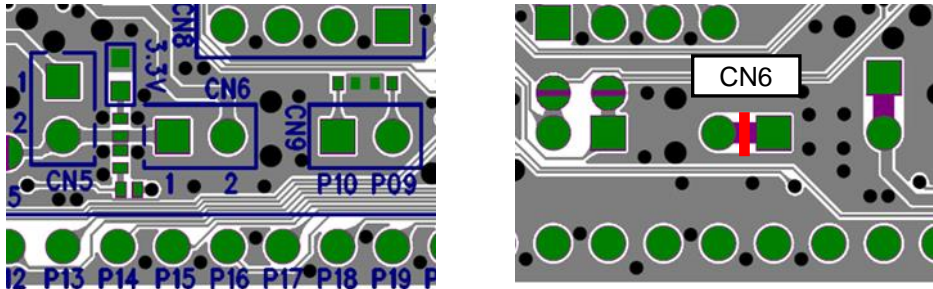

2) About the power supply of the module

When you use external power supply, please supply power from 15 and 16pin of CN3. On this configuration, please cut the short circuit 1pin and 2pin of CN5 in order to separate 3V3OUT of FT232RQ.

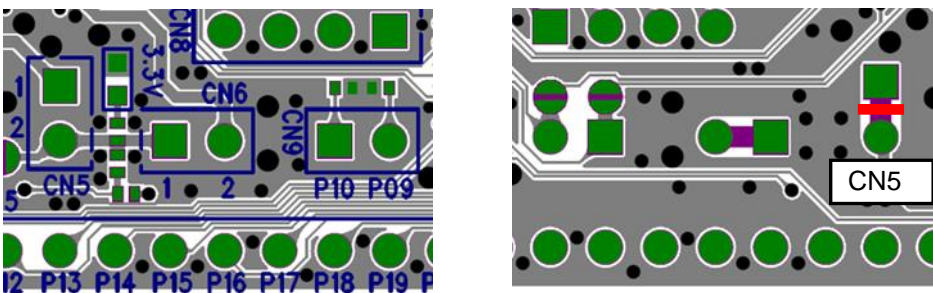

3) USB to serial UART interface

It needs to install driver of FT232RQ to use USB for UART interface. The drivers are available on FTDI website.

<http://www.ftdichip.com/Drivers/D2XX.htm>

In addition, by the application development, please assign GPIO as follows.

GPIO	UART
P0.05	RTS
P0.06	TX
P0.07	CTS
P0.08	RX

4) Size and Coordinate information

