

RoHS10 Support

REACH Support

CFSI Support

○形状 (SHAPE)

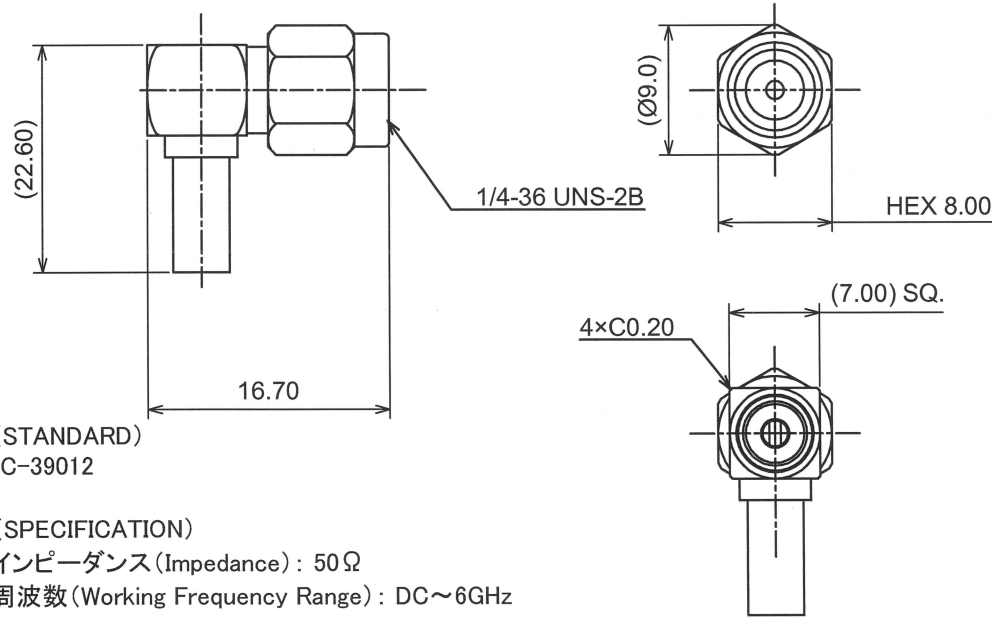

○加工寸法 (ASSEMBLY)

RECOMMENDED CABLE STRIPPING DIMS

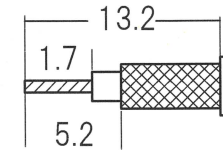

SOLDER CONTACT TO CABLE CENTER CONDUCTOR

RECOMMENDED CLIPPING TOOL SIZE

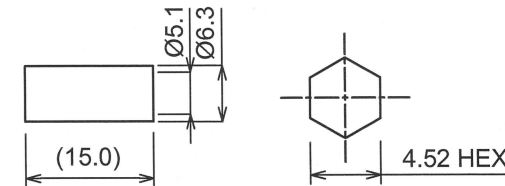

RECOMMENDED CRIMP HEIGHT 4.73±0.2

INTO THE INSULATOR AND PRESS IN THE CAP

The tolerance in this area is ± 0.10

○規格 (STANDARD)  
MIL-C-39012

○仕様 (SPECIFICATION)

- 特性インピーダンス (Impedance): 50  $\Omega$
- 定格周波数 (Working Frequency Range): DC~6GHz
- 電圧定在波比 (VSWR):  $\leq 1.45$  max at 6GHz
- 挿入損失 (Insertion Loss): 0.06 dB max  $\times \sqrt{f}$  GHz (f:Frequency)
- 定格電圧 (Voltage Rating): 335 Vrms max
- 耐電圧 (Proof Voltage): 750 Vrms max
- 勘合保証回数 (Connector Life): 500 times min
- 使用温度範囲 (Temperature range): -65°C~165°C
- 推奨締め付けトルク (Recommended Torque) 0.8~1.1 Nm

9	Cap	BRASS	GOLD
8	Ferrule	BRASS	NICKEL
7	Insulator	PTFE	NONE
6	Gasket	S. I. R	RED
5	R-ring	SUS304	NATURE
4	Coupling Nut	SUS303	PASSIVATE
3	Contact	BRASS	GOLD
2	Dielectric	PTFE	NONE
1	Body	BRASS	GOLD
No	DESCRIPTION	MATERIAL	FINISH



TOLERANCE				日本エレパーツ株式会社 NIHON ELEPARTS Co.,LTD	
DECIMALS .XX ±0.10	.X ±0.13				
DIAMETER .X ±0.03					
Approved	Checked	Drawn	Unit	NAME	REV
'22.02.01 山崎	'22.02.01 大江	'22.02.01 大江	mm		
			A4	SMA-PL-2.5DHQ	2