

RoHS10 Support

REACH Support

CFSI Support

○形状 (SHAPE)

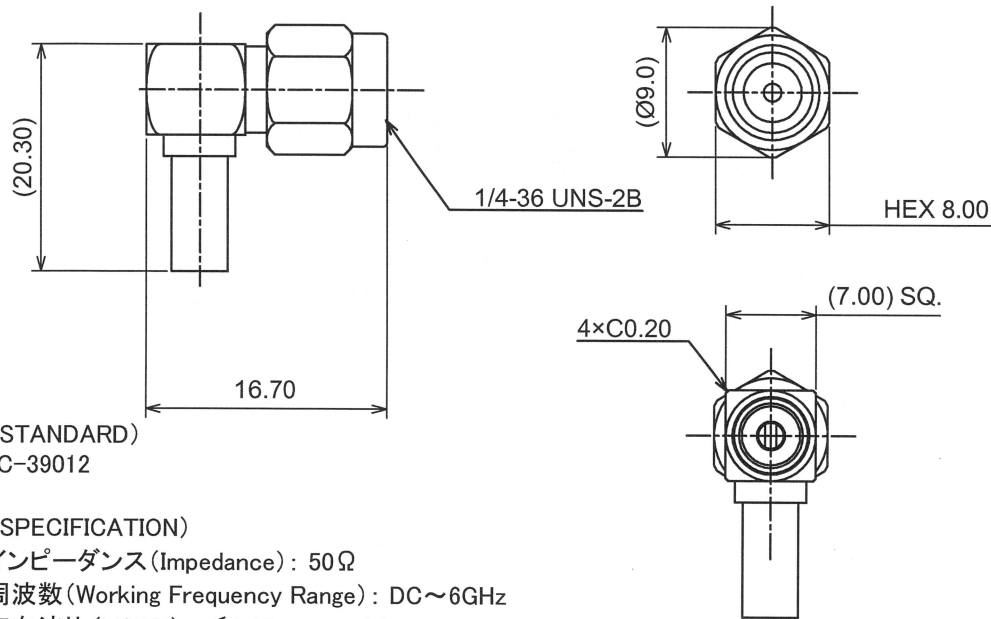

○規格 (STANDARD)
MIL-C-39012

○仕様 (SPECIFICATION)

- 特性インピーダンス (Impedance): 50 Ω
- 定格周波数 (Working Frequency Range): DC~6GHz
- 電圧定在波比 (VSWR): ≤ 1.45 max at 6GHz
- 挿入損失 (Insertion Loss): 0.06 dB max × √f GHz (f:Frequency)
- 定格電圧 (Voltage Rating): 335 Vrms max
- 耐電圧 (Proof Voltage): 750 Vrms max
- 勘合保証回数 (Connector Life): 500 times min
- 使用温度範囲 (Temperature range): -65°C~165°C
- 推奨締め付けトルク (Recommended Torque) 0.8~1.1 Nm

○加工寸法 (ASSEMBLY)

RECOMMENDED CABLE STRIPPING DIMS

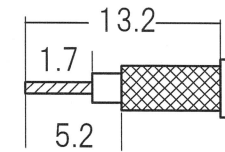

SOLDER CONTACT TO CABLE CENTER CONDUCTOR

RECOMMENDED CLIPPING TOOL SIZE

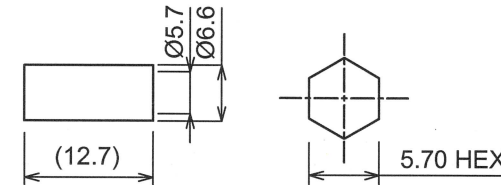

RECOMMENDED CRIMP HEIGHT 5.70±0.2

INTO THE INSULATOR AND PRESS IN THE CAP

The tolerance in this area is ± 0.10

9	Cap	BRASS	GOLD
8	Ferrule	BRASS	NICKEL
7	Insulator	PTFE	NONE
6	Gasket	S.I.R	RED
5	R-ring	SUS304	NATURE
4	Coupling Nut	SUS303	PASSIVATE
3	Contact	BRASS	GOLD
2	Dielectric	PTFE	NONE
1	Body	BRASS	GOLD
No	DESCRIPTION	MATERIAL	FINISH



TOLERANCE				日本エレパーツ株式会社 NIHON ELEPARTS Co.,LTD	
DECIMALS .XX ±0.10	.X ±0.13				
DIAMETER .X ±0.03					
Approved	Checked	Drawn	Unit	NAME SMA-PL-RG58AU REV 2	
22.02.01 山崎	22.02.01 大江	22.02.01 大江	mm		
			A4		