

RoHS10 Support

REACH Support

CFSI Support

IP66 Waterproof after mating (Before the panel)

○形状 (SHAPE)

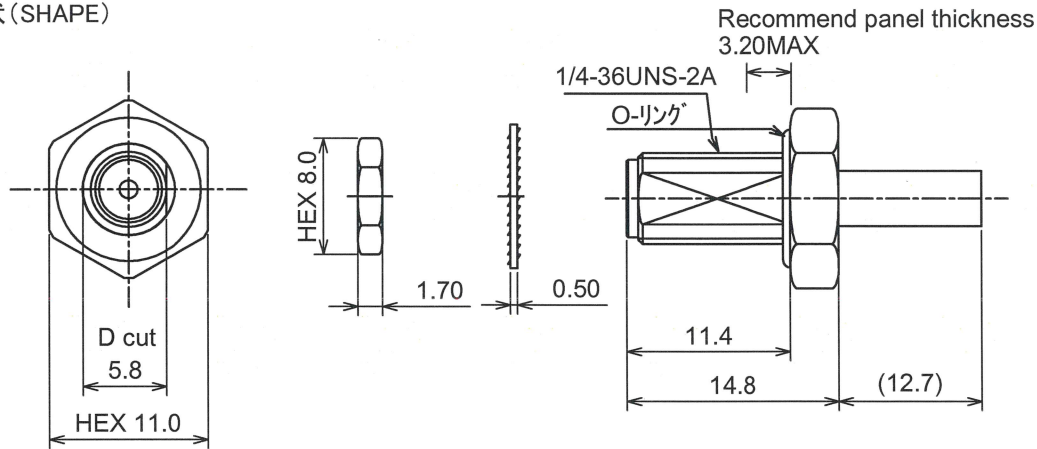

○規格 (STANDARD)

MIL-C-39012

○仕様 (SPECIFICATION)

- 特性インピーダンス (Impedance) : 50 Ω
- 定格周波数 (Working Frequency Range) : DC~6GHz
- 電圧定在波比 (VSWR) : ≤ 1.25 max at 6GHz
- 挿入損失 (Insertion Loss) : 0.04 dB max × √f GHz (f:Frequency)
- 定格電圧 (Voltage Rating) : 250 Vrms max
- 耐電圧 (Proof Voltage) : 500 Vrms max
- 勤合保証回数 (Connector Life) : 500 times min
- 使用温度範囲 (Temperature range) : -65°C~155°C
- 推奨締め付けトルク (Recommended Torque) 0.8~1.1 Nm

RECOMMENDED MOUNTING HOLE

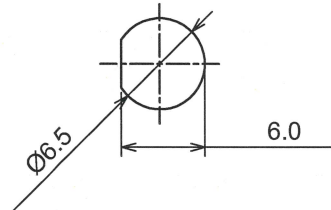

○加工寸法 (ASSEMBLY)

RECOMMENDED CABLE STRIPPING DIMS

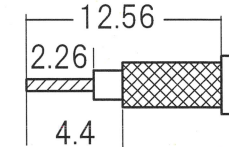

SOLDER CONTACT TO CABLE CENTER CONDUCTOR

RECOMMENDED CLIPPING TOOL SIZE

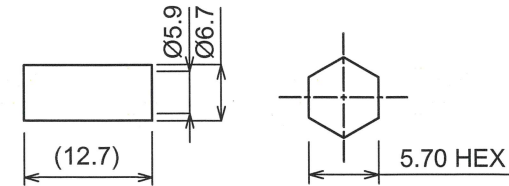

RECOMMENDED CRIMP HEIGHT 5.76±0.2

The tolerance in this area is ± 0.10

| No | DESCRIPTION | MATERIAL | FINISH |
|----|-------------|----------|--------|
| 7 | O-ring | S. I. R | RED |
| 6 | Washer | BRASS | NICKEL |
| 5 | Nut | BRASS | NICKEL |
| 4 | Ferrule | BRASS | NICKEL |
| 3 | Contact | BeCu | GOLD |
| 2 | Dielectric | PTFE | NONE |
| 1 | Body | BRASS | NICKEL |



| TOLERANCE | | | Unit | 日本エレパーツ株式会社 NIHON ELEPARTS Co.,LTD | |
|-----------|--------------------------|--------------------------|------|---------------------------------------|-----|
| DECIMALS | .XX ±0.08 | .X ±0.13 | | | |
| DIAMETER | .X ±0.03 | | mm | SMA-RSFB-3D | REV |
| Approved | Checked | Drawn | | | 2 |
| | エレパーツ '22.02.01 山崎 | エレパーツ '22.02.01 大江 | A4 | | |