

RoHS10 Support

REACH Support

CFSI Support

IP66 Waterproof after mating (Before the panel)

○形状 (SHAPE)

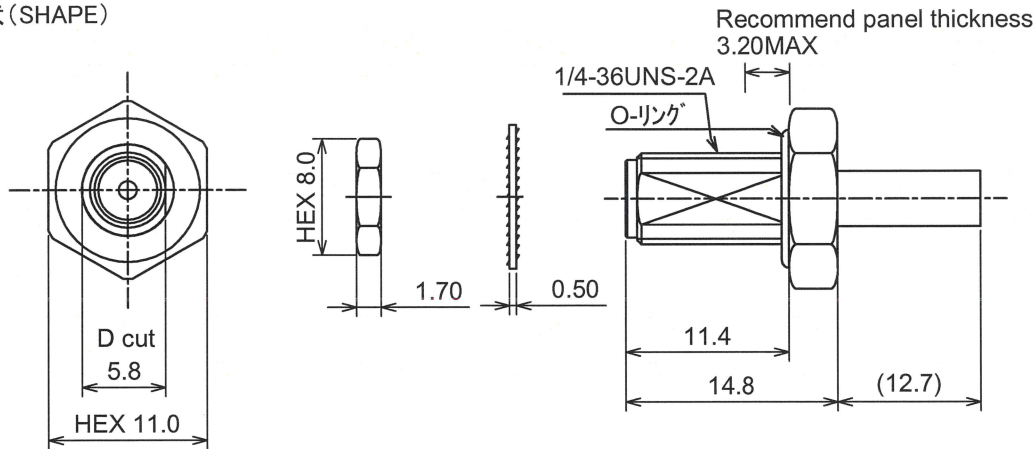

○規格 (STANDARD)

MIL-C-39012

○仕様 (SPECIFICATION)

- 特性インピーダンス (Impedance): 50Ω
- 定格周波数 (Working Frequency Range): DC~6GHz
- 電圧定在波比 (VSWR): ≤1.25 max at 6GHz
- 挿入損失 (Insertion Loss): 0.04 dB max × √f GHz (f:Frequency)
- 定格電圧 (Voltage Rating): 250 Vrms max
- 耐電圧 (Proof Voltage): 500 Vrms max
- 勤合保証回数 (Connector Life): 500 times min
- 使用温度範囲 (Temperature range): -65°C~155°C
- 推奨締め付けトルク (Recommended Torque) 0.8~1.1 Nm

RECOMMENDED MOUNTING HOLE

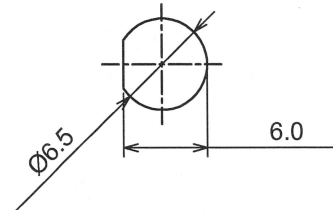

○加工寸法 (ASSEMBLY)

RECOMMENDED CABLE STRIPPING DIMS

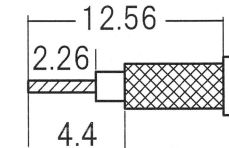

SOLDER CONTACT TO CABLE CENTER CONDUCTOR

RECOMMENDED CLIPPING TOOL SIZE

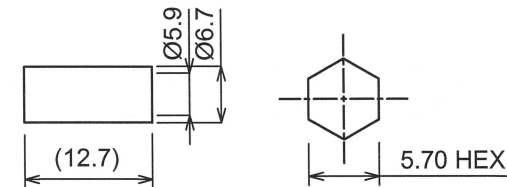

RECOMMENDED CRIMP HEIGHT 5.76±0.2

The tolerance in this area is ± 0.10

No	DESCRIPTION	MATERIAL	FINISH
7	O-ring	S . I . R	RED
6	Washer	BRASS	NICKEL
5	Nut	BRASS	NICKEL
4	Ferrule	BRASS	NICKEL
3	Contact	BeCu	GOLD
2	Dielectric	PTFE	NONE
1	Body	BRASS	NICKEL



TOLERANCE			Unit	日本エレパーツ株式会社 NIHON ELEPARTS Co.,LTD	
DECIMALS	.XX ±0.08	.X ±0.13			
DIAMETER	.X ±0.03		mm	NAME	REV
Approved	Checked	Drawn	A4		SMA-RSFB-RG223U