

***Bluetooth*[®] low energy Module**

Bluetooth[®] 4.2 low energy

EYSGCNAWY-VX

Data Report

顧客は、この文書に記載されている製品を購入することにより、この文書の内容を理解し合意承諾したものとみなします。

Bluetooth[®] とそのロゴマークは、Bluetooth SIG, Inc.の商標で、太陽誘電株式会社はライセンスに基づき使用しています。

EYSGCNAWY-VX

TAIYO YUDEN CO., LTD.

文書リスト

文書名	管理番号	ページ
一般事項書	HD-AG-A181108	1/5 - 5/5
絶対最大定格	HD-AM-A181108	1/1
電気的特性	HD-AE-A181108	1/2 - 2/2
回路図	HD-MC-A181108	1/3 - 3/3
外形寸法図	HD-AD-A181108	1/3 - 3/3
ピンレイアウト	HD-BA-A181108	1/1
取扱注意要領	HQ-BA-537	1/2 - 2/2
梱包仕様書	HD-BB-A181108	1/3 - 3/3
アンテナアプリケーションノート		1/3 - 3/3
デザインガイド		1/1
ソフトウェアマニュアル		1/86- 86/86
その他、注意事項について	HQ-BK-002_02	1/2 - 2/2

変更履歴

23-Apr.-2019 > Ver.1.0 Release

EYSGCNAWY-VX

TAIYO YUDEN CO., LTD.

Control No. HD-AG-A181108	(1/5)	Control name 一般事項書
------------------------------	-------	-----------------------

適用

本仕様書は、太陽誘電株式会社(“弊社”)により製造される **Bluetooth**® 4.2 low energy モジュール “EYSGCNAWY-VX” (“本製品”)に適用します。

1. 認証品名: EYSGCN

ユーザーコード: EYSGCNAWY-VX

*ユーザーコードは量産時などに変更されることがあります。

2. 機能:

無線モジュール **Bluetooth**® Ver 4.2 low energy 規格準拠

3. アプリケーション: ヘルスケア、フィットネス機器、センサ、玩具等

4. 構造:

シリコンモノリシック半導体を用いた混成集積回路

業界標準のリフロープロファイルでの Pb フリー実装に対応

RoHS 準拠 (Pb, Cd, Hg, Cr⁺⁶, PBB, PBDE)

5. 外形: 12.9x 9.6 x 2.0 mm

49ピン ランドグリッドアレイ

6. 表示: 品名, ロット番号, 電波法 ID (日本、米国、カナダ)

7. 特徴:

- 小型プリント基板モジュール
- 低消費電力
- アンテナ内蔵
- システムクロック、スリープクロック内蔵
- **Bluetooth**® 4.2 low energy 規格準拠
- Slave 側または Master 側対応

8. 梱包形態:

テープ&リール + アルミ防湿袋

梱包数量: 1000

*サンプル時はトレイで提供されることがあります。

TAIYO YUDEN CO., LTD.

EYSGCNAWY-VX

TAIYO YUDEN CO., LTD.

Control No. HD-AG-A181108	(2/5)	Control name 一般事項書
------------------------------	-------	-----------------------

9. その他:

- a. 本仕様書に疑義の生じた場合は、打ち合わせにより解決します。
- b. 本製品は、耐放射線設計をしておりませんので、放射線のストレスを受ける環境下での使用は避けて下さい。
- c. 本保証条件以外の条件で御使用になった結果発生した不良・不具合につきましては、弊社は責任を負い兼ねますので御了承下さい。また、過電圧等本保証条件以外の条件で御使用になった場合、ショートモードで破壊する場合があります。安全性の確保のために、フューズや過電流保護回路等の追加をお願い致します。
- d. 本仕様書に記載されている本製品は、ヘルスケア、フィットネス機器、センサ、玩具用として製造されております。従って、高度の安全性や信頼性が求められる医療用機器、宇宙用機器、あるいは防災機器等にお使いになるときは、本製品の適合性をお客様の独自の責任で十分に評価、検討され、判断下さい。又、一般機器において御使用になる場合にも、お客様の独自の責任で十分な安全性評価を実施され、必要に応じて設計時に保護回路等を追加してください。
- e. a) 弊社では、本製品に内蔵されているファームウェアについて十分な品質評価・検証を行っておりますが、お客様におかれましても本製品の量産開始前までに、内蔵ファームウェアに瑕疵やその他品質上の不具合、お客様の製品への組み込み上の不具合がない事を十分に評価され、お客様での本製品の使用用途に合致するものであることをご確認頂けますようお願い申し上げます。
b) 内蔵するソフトウェアのバグまたは不良に起因する不具合に対して弊社は一切責任を負いません。
- f. 弊社は納入後一年間、本製品が本仕様書を満足することを保証します。
- g. 本製品と他製品の通信は、周囲の電波環境及び機器環境により確立又は維持が難しくなることがあります。
- h. 本製品を搭載した製品の電波法認証試験を行うためには、モジュールをテストモードに入れる必要があります。詳細は太陽誘電にお問い合わせ下さい。
- i. 本製品は 2.4GHz 帯の周波数を使用しています。本製品を本製品と同じ周波数を使用した他の無線機器の周辺でご使用になりますと、本製品とかかる他の無線機器との間で電波干渉が発生する可能性があります。電波干渉が発生した場合、他の無線機器を停止するか、本製品の使用場所を変えるなど電波干渉の生じない環境でご使用下さい。
- j. 量産以降前にお客様の製品上で十分にモジュールを評価して下さい。
- k. ユーザーコードの変更
サンプルモジュールのユーザーコードまたは本仕様書中の品名は、太陽誘電の標準品名です。仕様の変更によりモジュールに変更がある場合には、品名が変わります。
以下に挙げる例のような場合に品名が変わります。
 - ファームウェアバージョンの変更（標準品のファームウェアもバージョンアップすることがあります。）
 - その他、設定の変更、外形の変更、表示の変更など

TAIYO YUDEN CO., LTD.

EYSGCNAWY-VX

TAIYO YUDEN CO., LTD.

Control No. HD-AG-A181108	(3/5)	Control name General Items
------------------------------	-------	-------------------------------

- l. 本製品を構成する部材の一部について、代替品を使用する場合があります。代替使用は、本仕様書に記載された保証範囲(特性、外形、使用条件、信頼性、公的規格(電波法等))、および品質に照らし、弊社にて代替(完全な置換え)が可能と判断致しました部材を対象とさせていただきます。尚、使用した部材種についての追跡性は製造ロット毎に確保されます。
- m. 輸出注意事項
本製品は、日本国の「外国為替及び外国貿易法」(関連法令・規則を含む)及び／又は諸外国の輸出管理関連法規に基づく輸出(再輸出を含む)申請、承認又は許可の対象となる場合があります。本製品を輸出(再輸出)する場合には、必ず事前にこれら関連法規が定める手続をご確認頂き、必要な場合には、お客様の責任と費用において適切な承認・許可をお取りください。
- n. 日本規制情報
本製品は、特定アンテナとの組み合わせにおいて工事設計認証を受けた無線設備です。
a) 御社製品に下記を明示願います。製品が小さく明示できない場合には、製品の見やすい箇所(取扱説明書および梱包又は容器を含む)に明示をお願いします。
本製品には、電波法に基づく小電力データ通信システムの無線局として、工事設計認証を受けた無線設備を内蔵しています。
EYSGCN : 001-A06158
- o. カナダ規制情報
a) 本装置は IC ライセンスを免除された RSS 標準に準じております。動作は下記の 2 条件に従います。(1) 本装置は、妨害波の原因とはなりません。(2) 本装置は、好ましくない装置動作の原因となるどのような妨害波を受信した 場合も受け入れます。
This device complies with Industry Canada license-exempt RSS standards. Operation is subject to the following two conditions: (1) this device may not cause interference, and (2) this device must accept any interference, including interference that may cause undesired operation of the device.
L'utilisation de ce dispositif est autorisée seulement aux conditions suivantes: (1) il ne doit pas produire de brouillage et (2) l'utilisateur du dispositif doit être prêt à accepter tout brouillage radioélectrique reçu, même si ce brouillage est susceptible de compromettre le fonctionnement du dispositif.
b) 本製品は Industry Canada によりポータブルデバイスとして認証を受けています。人体暴露要求の遵守維持のため、本製品の仕様で示す範囲でご使用下さい。
This product is certified as type of the portable device with Industry Canada Riles. To maintain compliance with RF Exposure requirement, please use within specification of this product.
Ce produit est certifié comme type de l'appareil portable avec Industrie Règles de Canada. Pour maintenir l'acquiescement avec exigence Exposition de RF, veuillez utiliser dans spécification de ce produit.
- IC: 4389B-EYSGCN
- c) 本製品を組み込む製品には、認証 ID を下記いずれかの方法で記載をお願いします。
Please notify certified ID by either one of the following method in your product.
Specifiez ID certifiée dans votre produit par une de méthode suivante.
-Contains Transmitter module IC : 4389B-EYSGCN
-Contains IC : 4389B-EYSGCN

TAIYO YUDEN CO., LTD.

EYSGCNAWY-VX

TAIYO YUDEN CO., LTD.

Control No. HD-AG-A181108	(4/5)	Control name General Items
------------------------------	-------	-------------------------------

p. FCC 規制情報

- a) 本装置は FCC 規則第 15 章に準拠しています。動作は下記の 2 条件に従います。(1) 本装置は、有害な妨害波の原因とはなりません。(2) 本装置は、好ましくない装置動作の原因となるどのような妨害波を受信した場合も受け入れます。

This device complies with part 15 of the FCC Rules. Operation is subject to the following two conditions: (1) This device may not cause harmful interference, and (2) this device must accept any interference received, including interference that may cause undesired operation.

- b) 本製品を組み込む製品には、認証 ID を下記いずれかの方法で記載をお願いします。

Please notify certified ID by either one of the following method.

-Contains Transmitter Module FCC ID: RYYEYSGCN

-Contains FCC ID: RYYEYSGCN

- c) 適合に責任を持つ当事者によって承認されていない変更や改造は、装置運用の認定が無効となります。

CAUTION: changes or modifications not expressly approved by the party responsible for compliance could void the use's authority to operate the equipment.

- d) 本製品は FCC によりポータブルデバイスとして認証を受けています。SAR 要件遵守維持のため、本製品の仕様で示す範囲でご使用ください。

This product is certified as type of the portable device with FCC Rules. To maintain compliance with RF Exposure requirement, please use within specification of this product.

- e) この無線機が使用するアンテナはいかなる他のアンテナ又は送信機と同一に配置しない、および同時に動作させないで下さい。

The antenna used for this transmitter must not be co-located or operating in conjunction with any other antenna or transmitter.

- f) このモジュールは、モジュール組み込み業者が開発するアプリケーションソフトウェアによって、状況に合わせて出力電力を設定できます。エンドユーザーは出力電力を変更することはできません。

This module can change the output power depending on the circumstances by the application software which is developed by module installer. Any end user cannot change the output power.

q. CE 規制情報

- a) 本装置を内蔵する EU 加盟国で流通する製品は別途認証手続きが必要です。

- b) 製品の認証手続きに無線部分の試験が必要となりますが、無線部分の Conducted 試験結果報告書を製品の認証の一部の資料としてご用意しています。

EYSGCNAWY-VX

TAIYO YUDEN CO., LTD.

Control No. HD-AG-A181108	(5/5)	Control name General Items
------------------------------	-------	-------------------------------

- r. 本製品は Bluetooth®4.2 の規格に従って製造された製品であり、本製品の用途が Bluetooth® 4.2 規格以外もしくは当該規格に従わない製品(「Bluetooth®4.2 規格外製品」)への使用の場合、弊社は第三者の知的財産権の侵害に基づきいかなる責任を負いません。また、弊社は本製品が本仕様書に準拠することのみを保証するもので、上記 Bluetooth®4.2 規格外製品への応用についての保証等いかなる保証を行うものではありません。
- s. EYSGCN シリーズモジュールは、PHY のみの Component カテゴリで Bluetooth SIG 認証を取得しています。このモジュールの QDID は 72109 です。最終製品は販売前に End Product として PHY (モジュール)、SoftDevice、プロファイルを組み合わせて認証を取得する必要があります。本製品の Link レイヤの QDID は 65785、また、Host レイヤの QDID は 79303 です。認証取得は以下の図をご参照頂き、お客様の認証機関、BQC にお問い合わせ下さい。

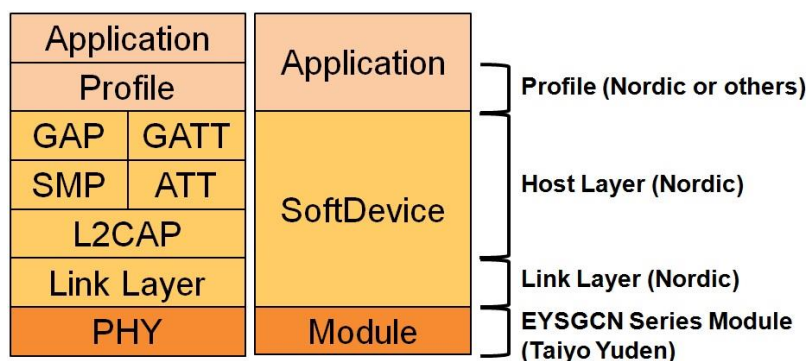

内蔵ソフトウェアについて

ご使用にあたって

本製品のご使用にあたっては、以下の事項をご理解頂き、ご了解頂いた上でご使用ください。

1. 太陽誘電株式会社(以下、「弊社」といいます)は、本製品に内蔵された記憶装置に書込まれたソフトウェア(以下、「内蔵ソフトウェア」といいます)に関する著作権その他の権利を適法に有しています。
弊社は、内蔵ソフトウェアの全部又は一部を問わず、本製品以外での使用、第三者への開示・提供(Webサイトへの内蔵ソフトウェアの掲載やそこからの第三者によるダウンロード等を含む)及び内蔵ソフトウェアの複製・改変・バージョンアップ・仕様変更、譲渡等(解析調査;Reverse engineering 含む)を禁止させていただきます。
2. 本製品を使用される際には、必ず事前に十分な安全性・動作性、他の機器との接続性・適合性等の評価を行い、使用に際し支障が無い事をご確認下さい。
3. 弊社では、あらゆる機器に対して本製品(内蔵ソフトウェア含む)の動作確認を実施しているわけではありません。
また、本仕様書は、本製品において特定の機器への接続性・適合性等を保証するものではありません。内蔵ソフトウェアの潜在的不具合及び各機器との組合せ等により問題が発生した場合にその損害を最小限に止める為にも、本製品を使用する製品に、内蔵ソフトウェアを書き換える為のインターフェイスや外部端子(詳細は本書“ピンレイアウト”を参照)を設けて戴くことを推奨致します。

TAIYO YUDEN CO., LTD.

EYSGCNAWY-VX

TAIYO YUDEN CO., LTD.

Control No. HD-AM-A181108	(1/1)	Control name 絶対最大定格
------------------------------	-------	------------------------

絶対最大定格

Symbol	Parameter	Min.	Max.	Units
VCC_NRF		-0.3	+3.6	V
GND			0	V
VIO		-0.3	VCC_NRF+ 0.3	V
Storage temperature		-40	+85	Deg-C
MSL	Moisture Sensitivity Level	3		
ESD HBM	Human Body Model		1	kV
ESD MM	Machine Model		100	V
Endurance	Flash Memory Endurance	20000		write/erase cycles
Retention	Flash Memory Retention	10 years		At 40 deg-C
Number of times an address can be written between erase cycles			2	times

EYSGCNAWY-VX

TAIYO YUDEN CO., LTD.

Control No. HD-AE-A181108	(1/2)	Control name 電气的特性
------------------------------	-------	-----------------------

電气的特性
推奨動作条件

Symbol	Parameter	Min.	Typ.	Max.	Units
VCC_NRF	Supply voltage, normal mode	1.8	3.0	3.6	V
tR_VCC_NRF	Supply rise time (0V to 1.8V)*1			100	ms
TA	Operation temperature	-25	25	85	Deg-C

*1 Rise time 仕様を超えるとチップ内のパワーオンリセット回路は正しく動作しないことがあります。
電源を切断後、再投入する場合は必ず 0.3V 以下に落としてから立ち上げて下さい。
同様にパワーオンリセット回路が正しく動作しないことがあります。

DC 仕様

Topr.= 25 °C, VCC_NRF = 3.0V で適用される仕様

Symbol	Parameter (condition)	Min.	Typ.	Max.	Units
VIH	Input high voltage	0.7 VCC_NRF		VCC_NRF	V
VIL	Input low voltage	GND		0.3 VCC_NRF	V
VOH	Output high voltage (std. drive, 0.5 mA)	VCC_NRF-0.3		VCC_NRF	V
VOH	Output high voltage (high-drive, 5 mA)	VCC_NRF-0.3		VCC_NRF	V
VOL	Output low voltage (std. drive, 0.5 mA)	GND		0.3	V
VOL	Output low voltage (high-drive, 5 mA)	GND		0.3	V
RPU	Pull-up resistance	11	13	16	kohm
RPD	Pull-down resistance	11	13	16	kohm
ITX,+4dBm	TX only run current @ POUT =+4 dBm		16		mA
IRX	RX only run current		13		mA
IOFF	Current in SYSTEM-OFF, no RAM retention		0.6		uA
RSTR	RESET High to Module Ready		300	600	ms
RPW	RESET Pulse Width		5		ms

UART specifications

Symbol	Description	Min.	Typ.	Max.	Units
f _{UART}	Baud rate for UART	9600		921600	bps

TAIYO YUDEN CO., LTD.

EYSGCNAWY-VX

TAIYO YUDEN CO., LTD.

Control No. HD-AE-A181108	(2/2)	Control name 電气的特性
------------------------------	-------	-----------------------

RF仕様

Symbol	Description	Min.	Typ.	Max.	Units
Fop	Operating frequencies	2402		2480	MHz
Df	Frequency deviation	+/-225	+/-250	+/-275	kHz
PRF	Maximum output power		4		dBm
PRFCR	RF power accuracy			+/-4	dB
PBW	20 dB bandwidth for modulated carrier		950	1100	kHz
PRF1	1st Adjacent Channel Transmit Power 1 MHz			-20	dBc
PRF2	2nd Adjacent Channel Transmit Power 2 MHz			-45	dBc
PRXMAX	Maximum received signal strength at < 0.1% PER		0		dBm
PSSENS IT	Receiver sensitivity (0.1% BER) Ideal transmitter		-93		dBm
PSSENS DT	Receiver sensitivity (0.1% BER) dirty transmitter		-91		dBm

nRF51822 の製品仕様や Product Anomaly Notification 等の多くの文書は下記リンクにあります。弊社モジュールを使用する際は、これらの最新の文書を必ずご確認ください。

Product Specification

https://infocenter.nordicsemi.com/topic/struct_nrf51/struct/nrf51822_ps.html?cp=4_4_0

Product Anomaly Notification

https://infocenter.nordicsemi.com/topic/struct_nrf51/struct/nrf51822_pan.html?cp=4_4_1

SoftDevice

https://infocenter.nordicsemi.com/topic/struct_nrf51/struct/s130.html?cp=4_7_2

For more information

<https://infocenter.nordicsemi.com/index.jsp>

EYSGCNAWY-VX

TAIYO YUDEN CO., LTD.

Control No. HD-MC-A181108	(1/3)	Control name 回路図
------------------------------	-------	---------------------

ブロックダイアグラム

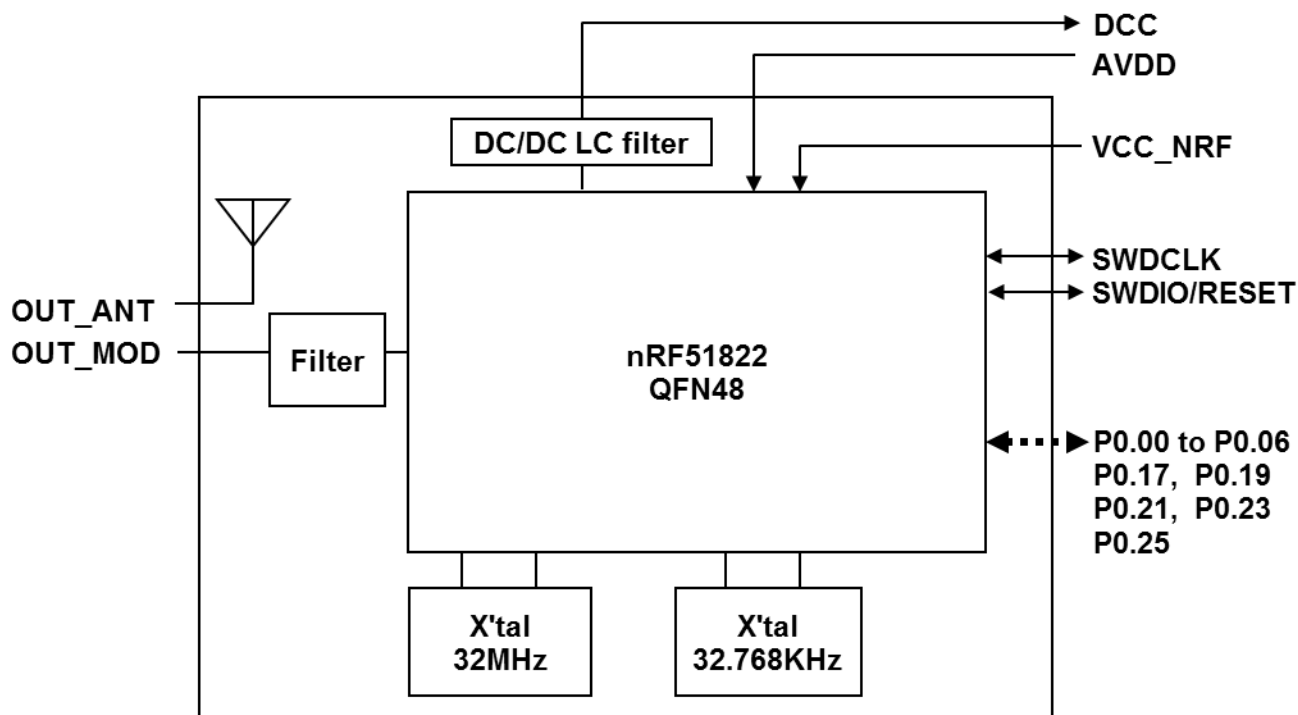

EYSGCNAWY-VX

TAIYO YUDEN CO., LTD.

Control No. HD-MC-A181108	(2/3)	Control name 回路図
------------------------------	-------	---------------------

参考回路

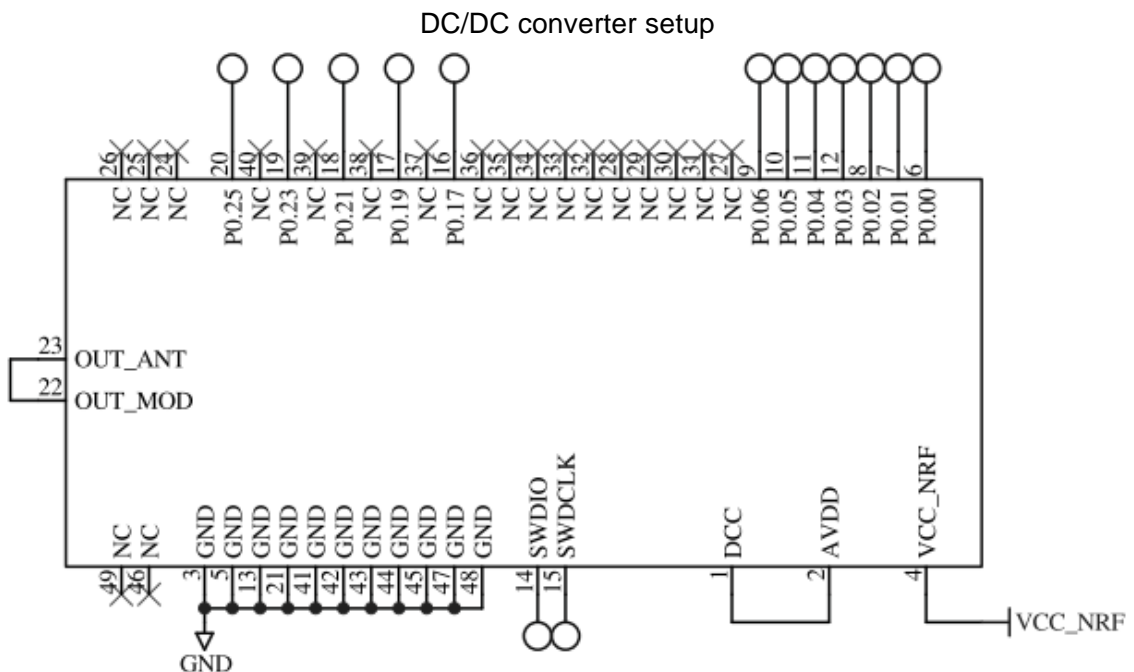
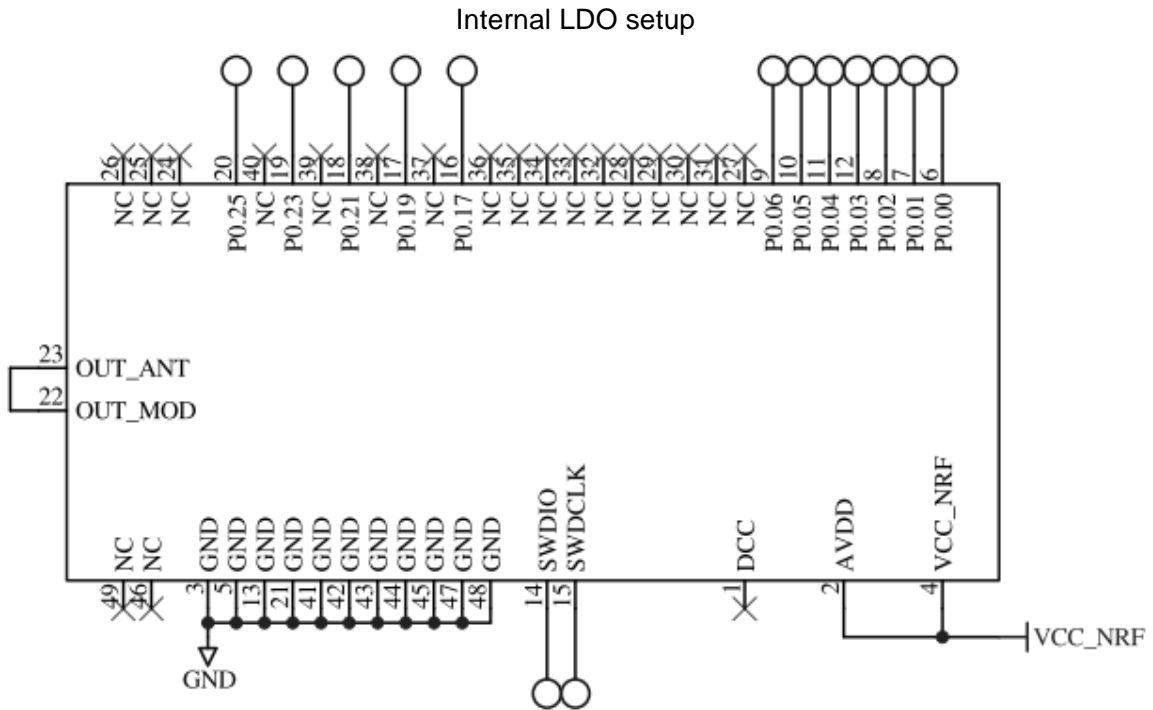

TAIYO YUDEN CO., LTD.

EYSGCNAWY-VX

TAIYO YUDEN CO., LTD.

Control No. HD-MC-A181108	(3/3)	Control name 回路図
------------------------------	-------	---------------------

リファレンス回路

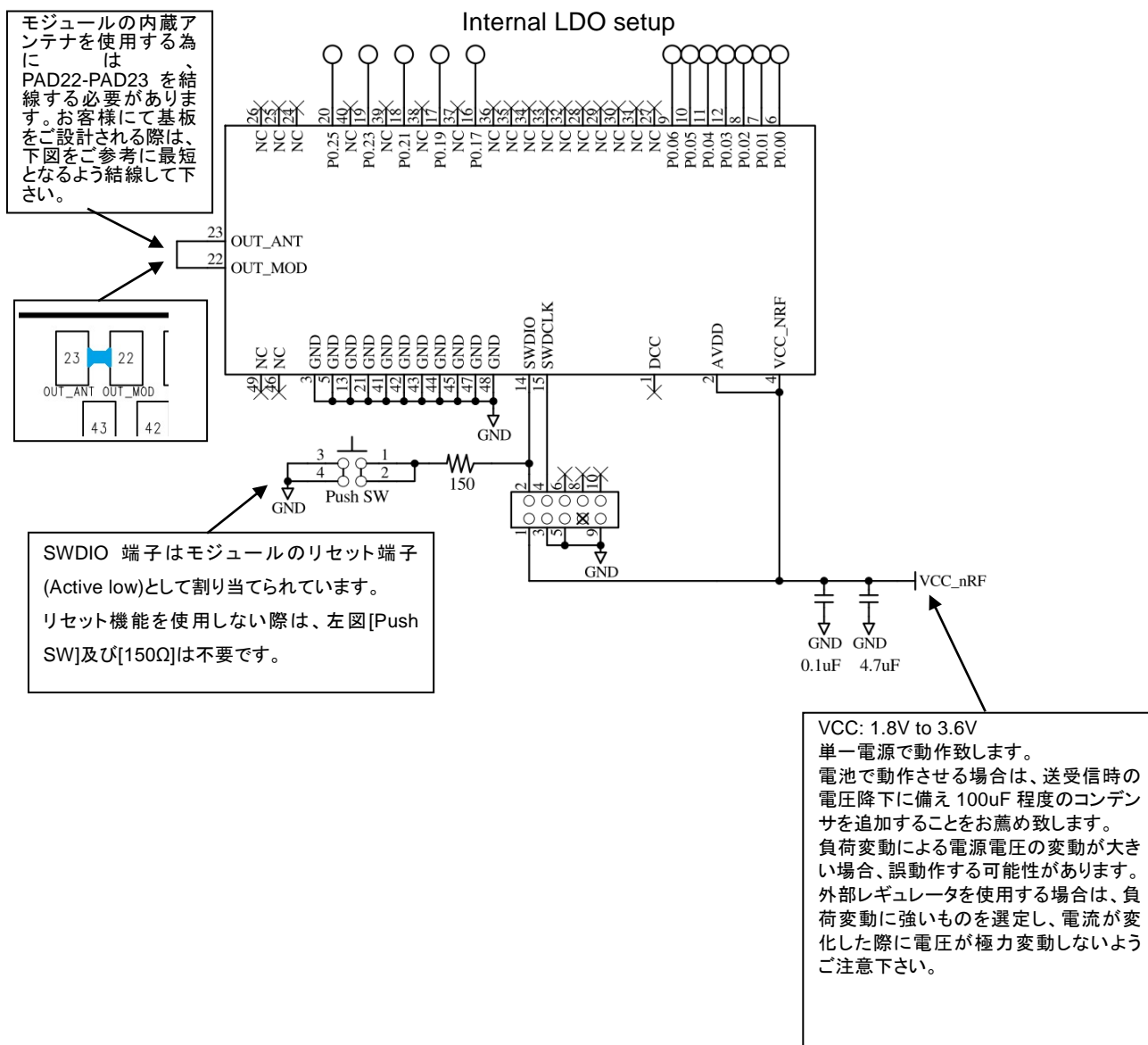

EYSGCNAWY-VX

TAIYO YUDEN CO., LTD.

Control No. HD-AD-A181108 (1/3)	Control name 外形寸法図
---------------------------------------	-----------------------

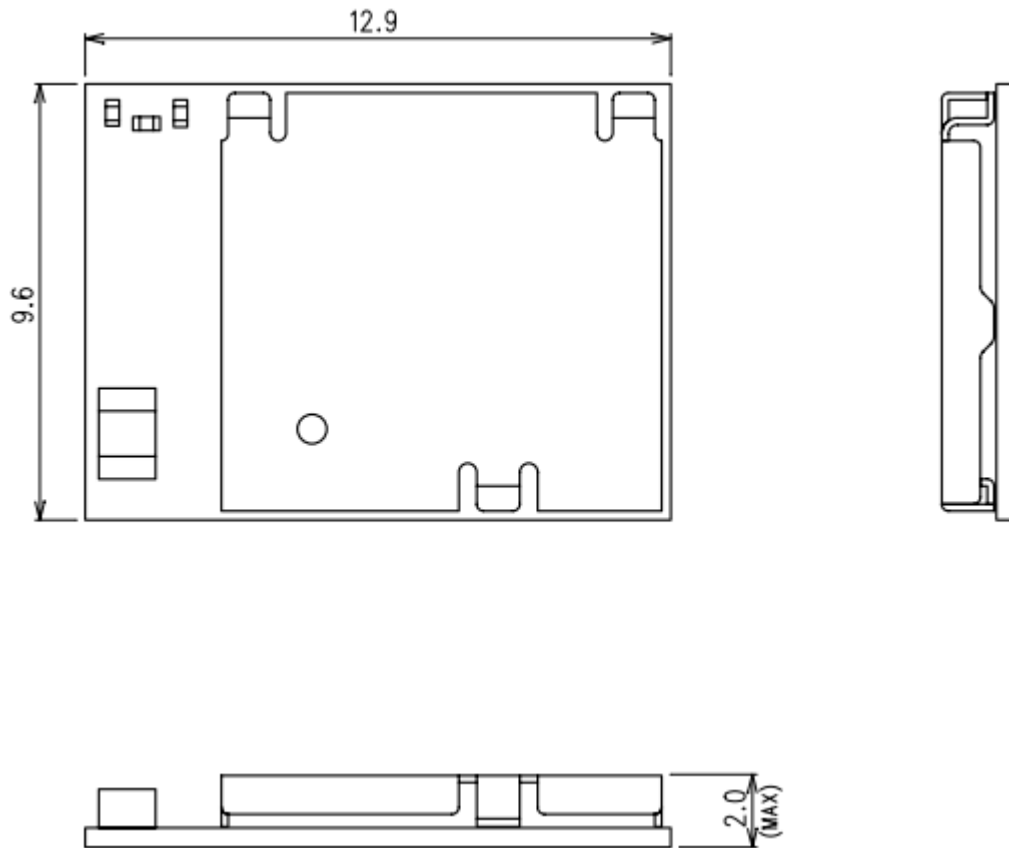

Tolerance: +/- 0.2mm
 Unit : (mm)

EYSGCNAWY-VX

TAIYO YUDEN CO., LTD.

Control No. HD-AD-A181108	(2/3)	Control name 外形寸法図
------------------------------	-------	-----------------------

(TOP VIEW)

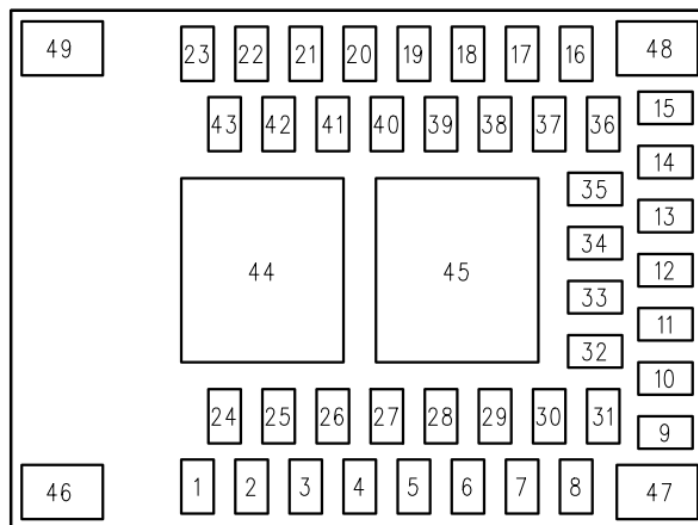
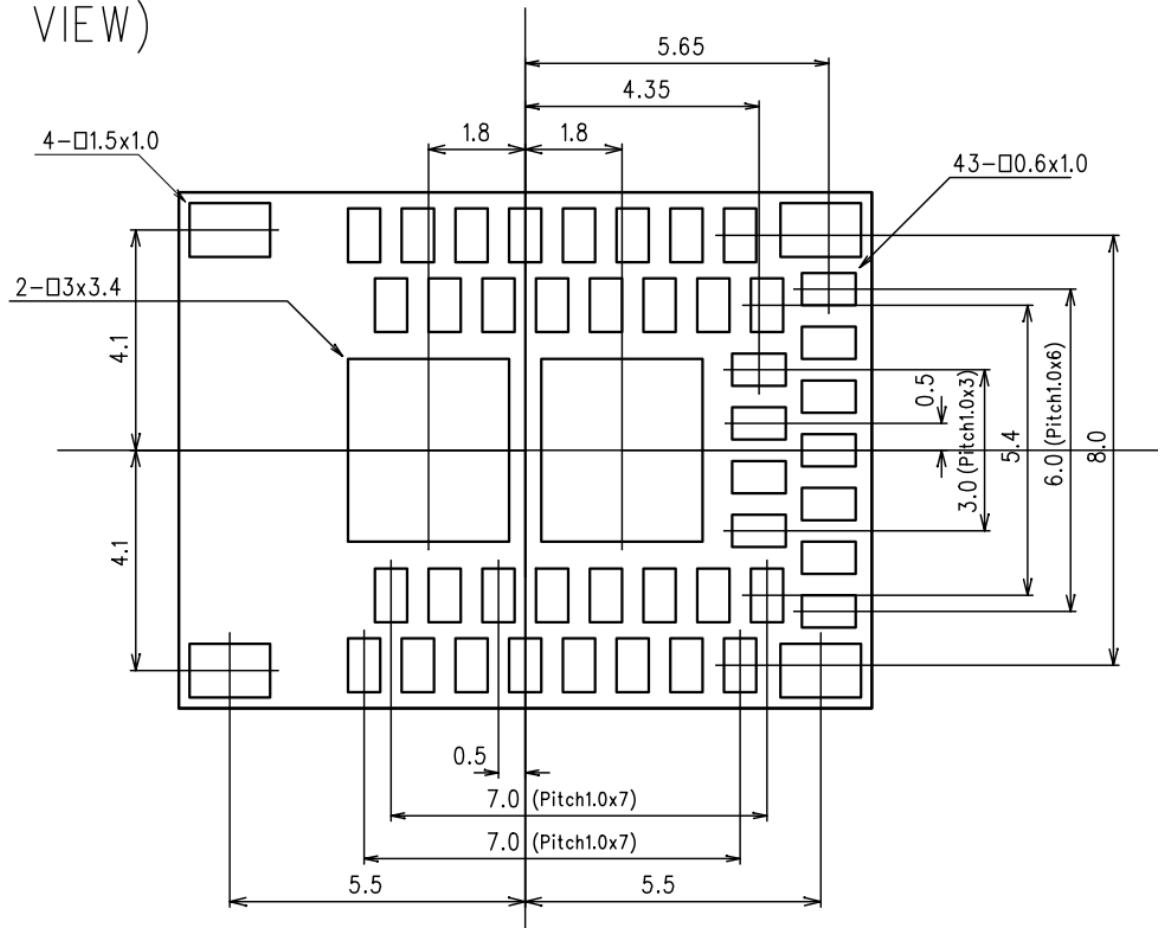

TAIYO YUDEN CO., LTD.

EYSGCNAWY-VX

TAIYO YUDEN CO., LTD.

Control No.
HD-AD-A181108

(3/3)

Control name
外形寸法図

LAND PATTERN EXAMPLE

(TOP VIEW)

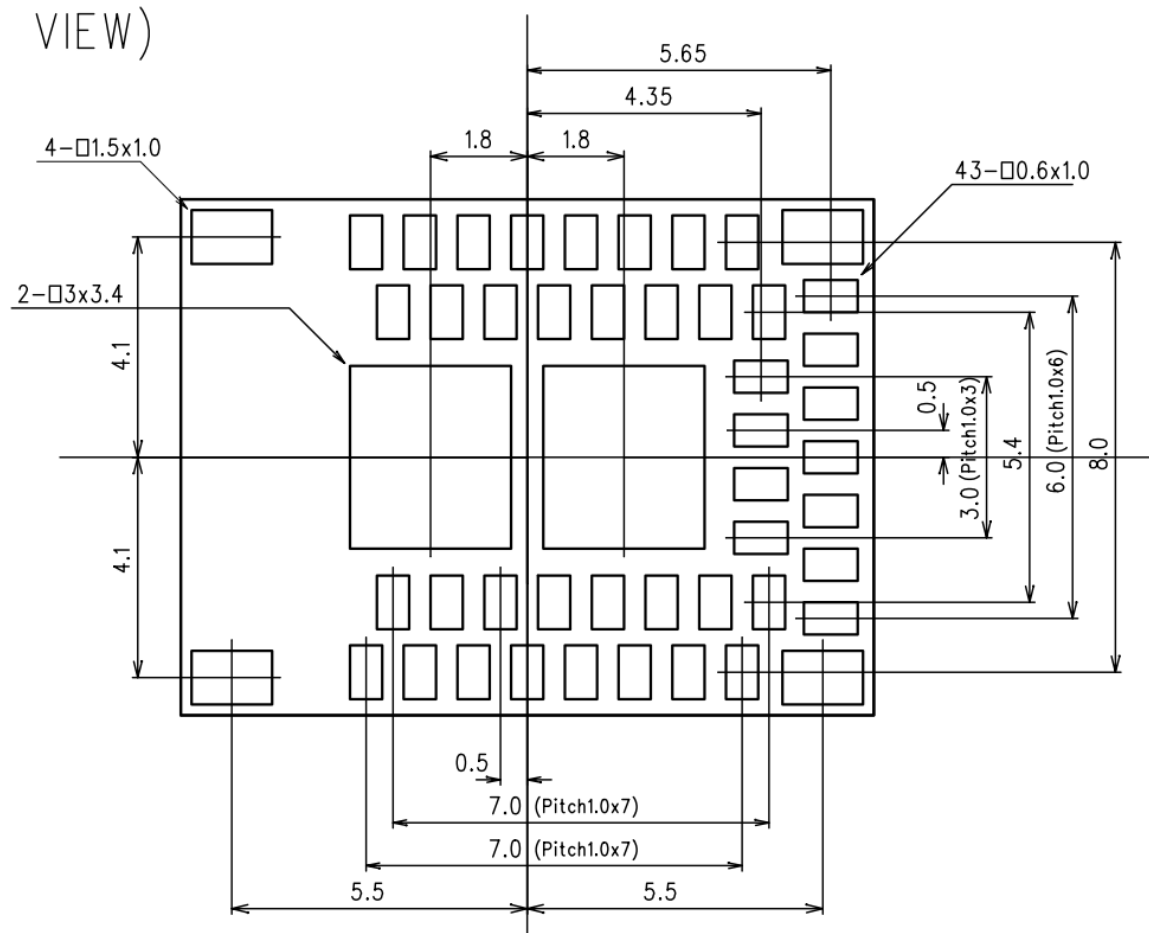

推奨ハンダ印刷メタルマスク

Pad size	Mask opening
Signal pad 43 - 0.6 x 1.0 mm	0.5 x 0.9 mm
Corner pad 4 - 1.5 x 1.0 mm	1.0 x 0.7 mm
Center pad 2 - 3.0 x 3.4 mm	2.6 x 3.0 mm

各開口部の中心は各パッドの中心です。

メタルマスク厚 0.1mm の場合です。異なる場合は同じ体積になるよう開口を調整して下さい

TAIYO YUDEN CO., LTD.

EYSGCNAWY-VX

TAIYO YUDEN CO., LTD.

Control No. HD-BA-A181108	(1/1)	Control name ピンレイアウト
------------------------------	-------	-------------------------

Pin Descriptions

Pin	Pin name	Pin function	Description
1	DCC	Power	Reserved
2	AVDD	Power	アナログ電源
3	GND	Ground	Ground (0 V)
4	VCC_NRF	Power	電源
5	GND	Ground	Ground (0 V)
6	P0.00	Digital Output	UART_RTS
7	P0.01	Digital Output	UART_TX
8	P0.02	Digital Input	UART_CTS
9	P0.06	Digital Input	Disconnect request / Resume from Power saving mode
10	P0.05	Digital Output	Module active / sleep indicate
11	P0.04	Digital Input	Forced initialize / Request Sleep mode
12	P0.03	Digital Input	UART_RX
13	GND	Ground	Ground (0 V)
14	SWDIO	Digital I/O	システムリセット(active low) ハードウェアデバッグ、Flash プログラミング I/O
15	SWDCLK	Digital input	ハードウェアデバッグ、Flash プログラミング I/O
16	P0.17	Digital Input	Request DFU mode
17	P0.19	Digital Output	State indication of module / DFU indication
18	P0.21	Digital Input	Sleep indication of host / Resume from Power saving mode
19	P0.23	Digital Output	Mode indication of module
20	P0.25	Digital Output	Wake up request
21	GND	Ground	Ground (0 V)
22	OUT_MOD	RF In/Out	RF I/O pin. 通常使用時は Pin 23 OUT_ANT に接続して下さい
23	OUT_ANT	Antenna In/Out	内部アンテナ. 通常使用時は Pin 22 OUT_MOD に接続して下さい
24 to 40	NC	Not Connected	Reserved for future use
41 to 45	GND	Ground	Ground (0 V)
46	NC	Not Connected	機械的強度向上のためのピン。基板上で独立したパッドとして下さい
47 to 48	GND	Ground	Ground (0 V)
49	NC	Not Connected	機械的強度向上のためのピン。基板上で独立したパッドとして下さい

TAIYO YUDEN CO., LTD.

EYSGCNAWY-VX

TAIYO YUDEN CO., LTD.

Control No. HQ-BA-537	(1/2)	Control name 取扱注意要領
--------------------------	-------	------------------------

本書類では特に実装時の御願い・条件について記載します。

御願い・条件

(1) 使用・保管環境の管理

1. 弊社出荷時の防湿梱包状態で保管する場合、**40°C/90%RH**以下の環境で保管してください。
2. 工程の環境は**30°C/60%RH**以下に管理してください。
3. モジュールを開梱状態で保管する(工程間の滞留含む)場合、**25±5°C/10%RH**以下の環境で保管してください。

(2) 製品取扱時の御願い・条件

防湿梱包品入庫後、防湿袋に穴、裂け、キズ等のない事を確認してください。万が一異常があった場合、(2)-2項に従い、処置をお願い致します。

梱包に貼付のラベルをご参照ください。

1. 梱包日から**12ヶ月以内**に**全ての**実装(リフロー)作業(リワーク含む)を終了してください。
2. 防湿梱包開梱後、直ちに湿度インジケータにて梱包内の環境が**<10%RH**であることを確認してください。
3. 開封後**168時間以内**に**全ての**実装作業(リワーク含むリフロー作業)を終了してください。
本モジュール以外の実装作業含みます
4. (1)項、及び(2)-2・(2)-3の基準からはずれた場合、**125°C 24h**にてベーキングを行ってください。
5. (2)-4項記載の条件によるベーキングは1回を原則とします。
6. 本モジュールは内部に半導体を有するため、取扱中には静電気に留意してください。(100V以下)必要に応じて、導電マット・アースバンド・静電靴・イオナイザー等を用いて、静電気の対策を講じてください。
7. 機械的振動、衝撃を極力少なくし、落下させないでください。
8. モジュールを実装する際には、裏面の電極を認識してください。
9. 本製品の洗浄は推奨しません。洗浄を行う場合は、洗浄、乾燥後に本製品機能を十分に確認してからご使用ください。尚、本製品への洗浄における不具合に関しましては、当社は一切の責任を負いません。
10. モジュールのリフロー時温度条件は、下記の範囲内で行って下さい。

リフロー回数は最大2回として下さい。

TAIYO YUDEN CO., LTD.

EYSGCNAWY-VX

TAIYO YUDEN CO., LTD.

Control No. HQ-BA-537	(2/2)	Control name 取扱注意要領
--------------------------	-------	------------------------

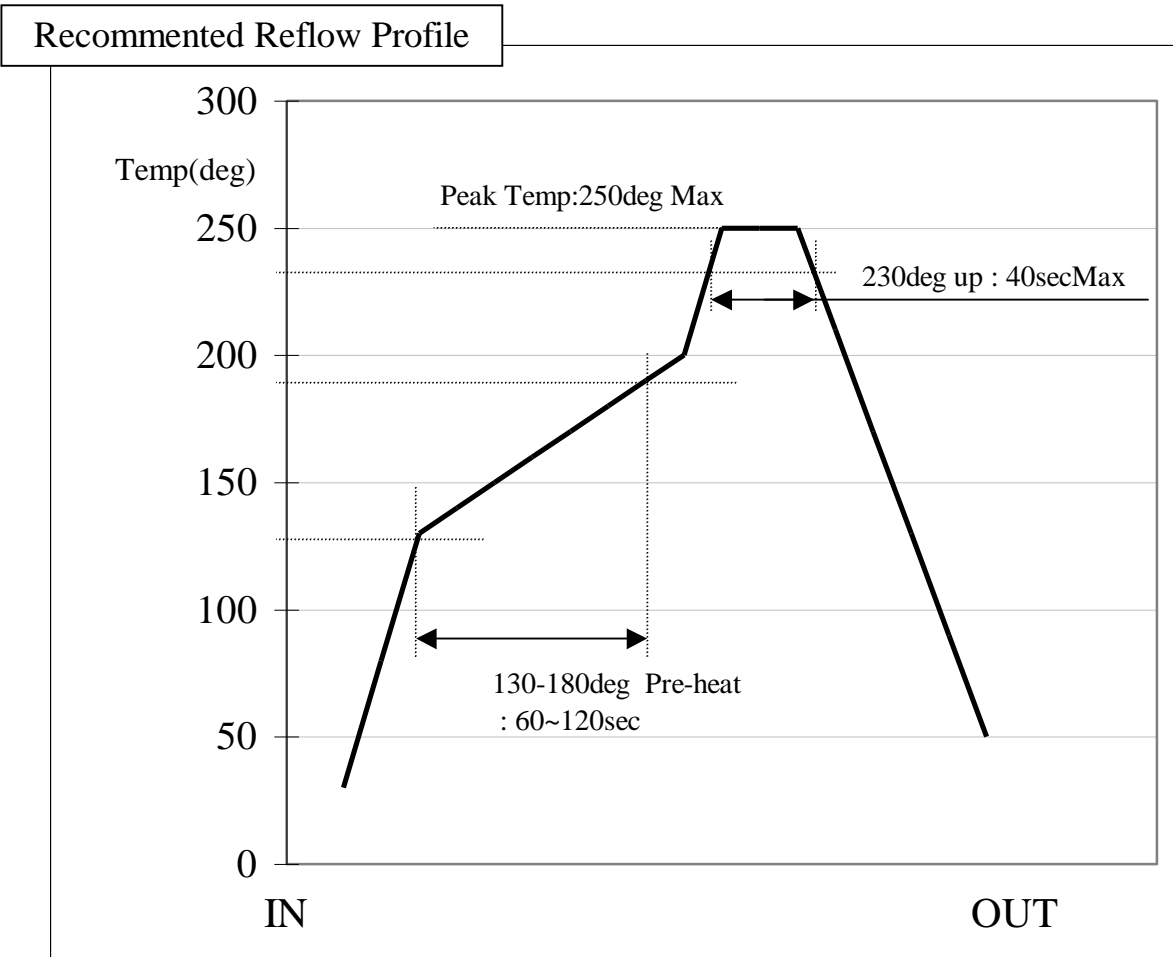

EYSGCNAWY-VX

TAIYO YUDEN CO., LTD.

Control No. HD-BB-A181108	(1/3)	Control name 梱包仕様書
------------------------------	-------	-----------------------

Packaging Specification

梱包仕様

(1) Packaging Material 梱包材料

Name 部材名	Outline 概要	Materials 材質	Note 備考
Emboss エンボス	24mm wide - 12mmPitch 24mm幅 - 12mmピッチ	Conductive PS 導電性 PS	
Cover Tape カバーテープ			
Reel リール	φ 330 mm	Conductive PS 導電性 PS	
Desiccant 乾燥剤	30g × 1		
Humidity indicator card 湿度インジケータ			
Aluminum moisture barrier bag アルミ防湿袋	420 × 460(mm)	(AS)PET/AL/NY/PE(AS)	
Label ラベル			
Corrugated cardboard box(Inner) 個装箱	339 × 351 × 74(mm)		
Corrugated cardboard box(Outer) 外装箱	369 × 369 × 277(mm)		

(2) Packaging Unit

梱包数量

Max 1000 pieces/Reel

Max 3000 pieces/Box(Outer)

(3) Packaging Figure

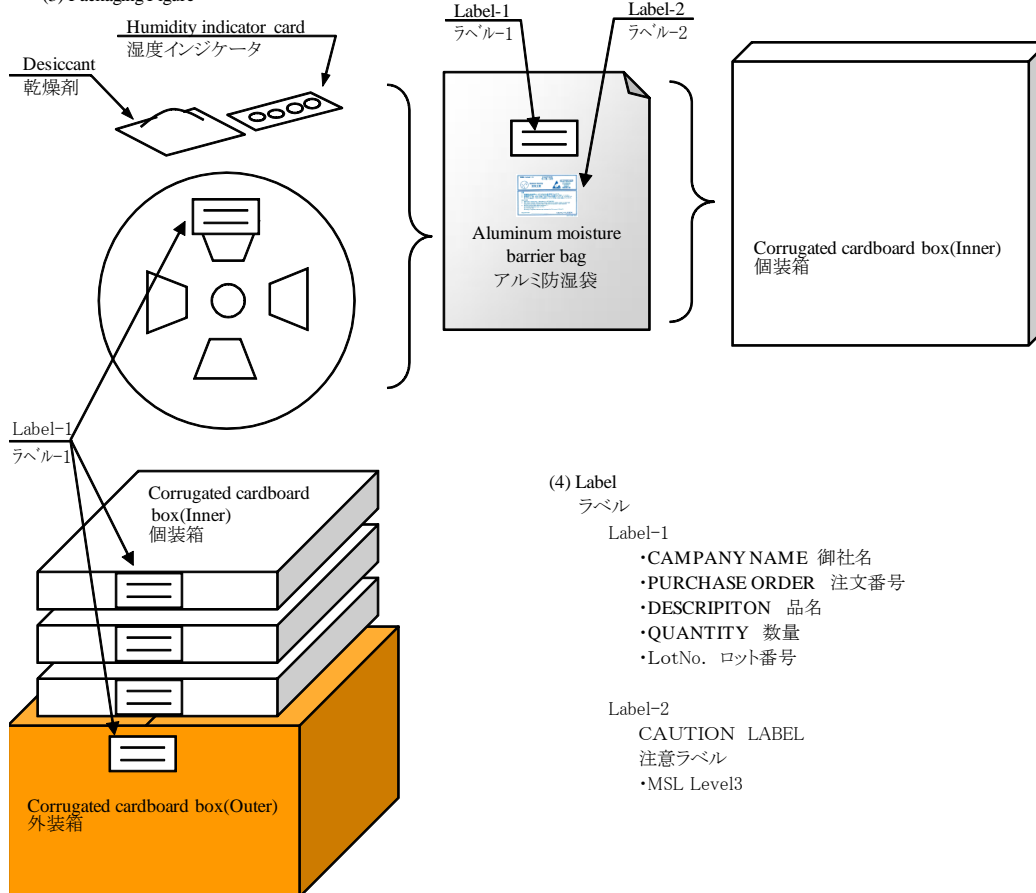

(4) Label

ラベル

Label-1

- COMPANY NAME 御社名
- PURCHASE ORDER 注文番号
- DESCRIPITON 品名
- QUANTITY 数量
- LotNo. ロット番号

Label-2

- CAUTION LABEL
- 注意ラベル
- MSL Level3

TAIYO YUDEN CO., LTD.

EYSGCNAWY-VX

TAIYO YUDEN CO., LTD.

Control No. HD-BB-A181108	(2/3)	Control name 梱包仕様書
------------------------------	-------	-----------------------

Tape specification
テーピング仕様

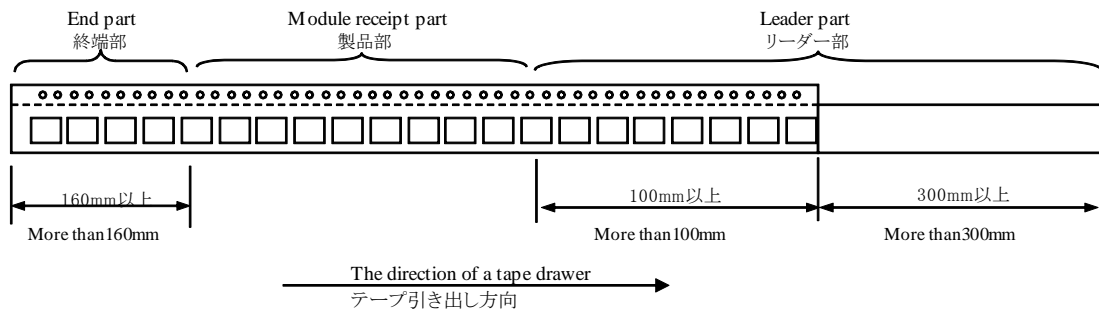
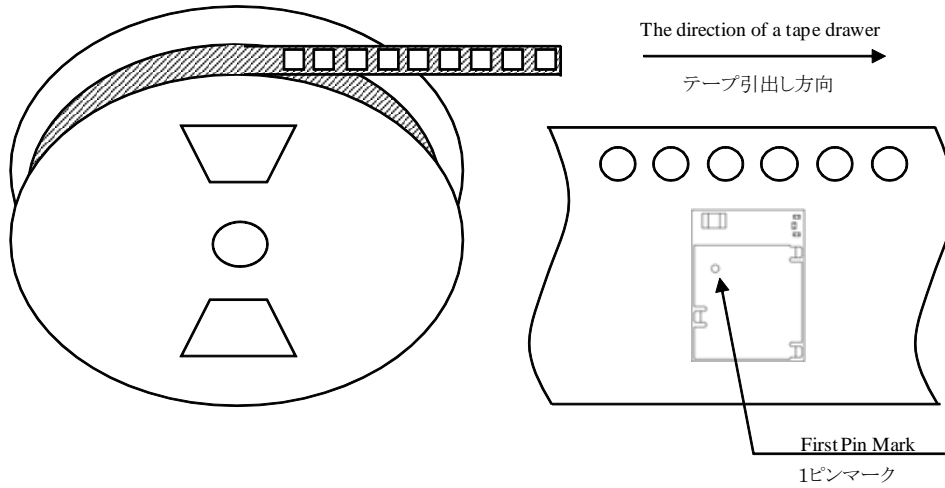

キャリアエンボス図面

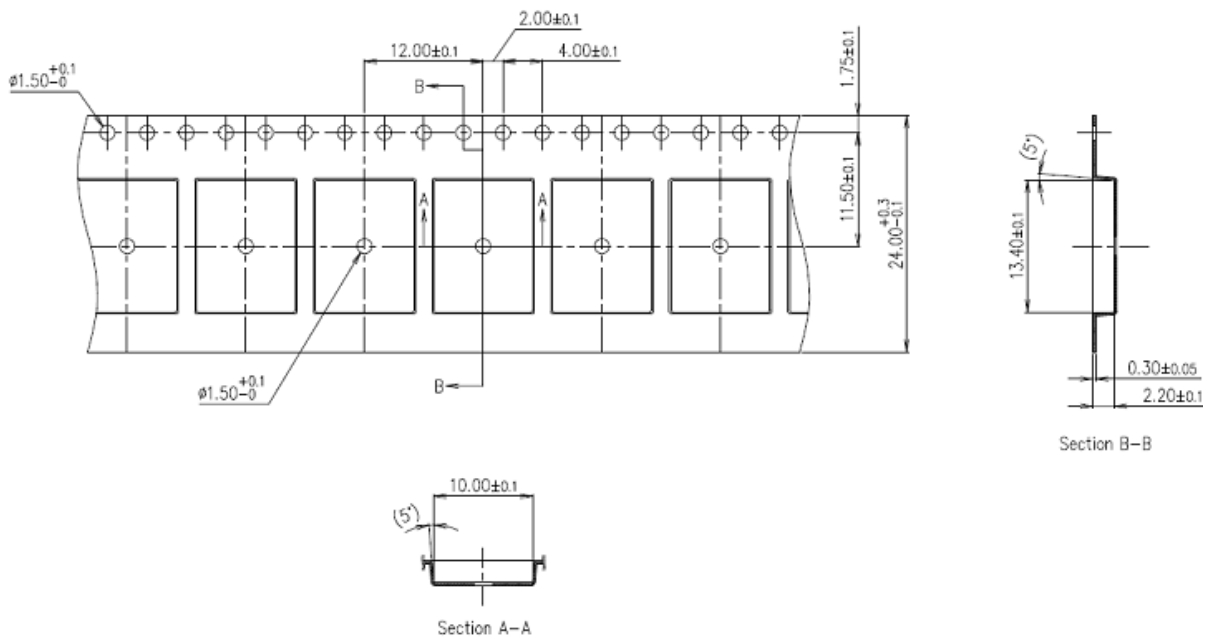

TAIYO YUDEN CO., LTD.

EYSGCNAWY-VX

TAIYO YUDEN CO., LTD.

Control No.
HD-BB-A181108

(3/3)

Control name
梱包仕様書

Reel specification
リール仕様

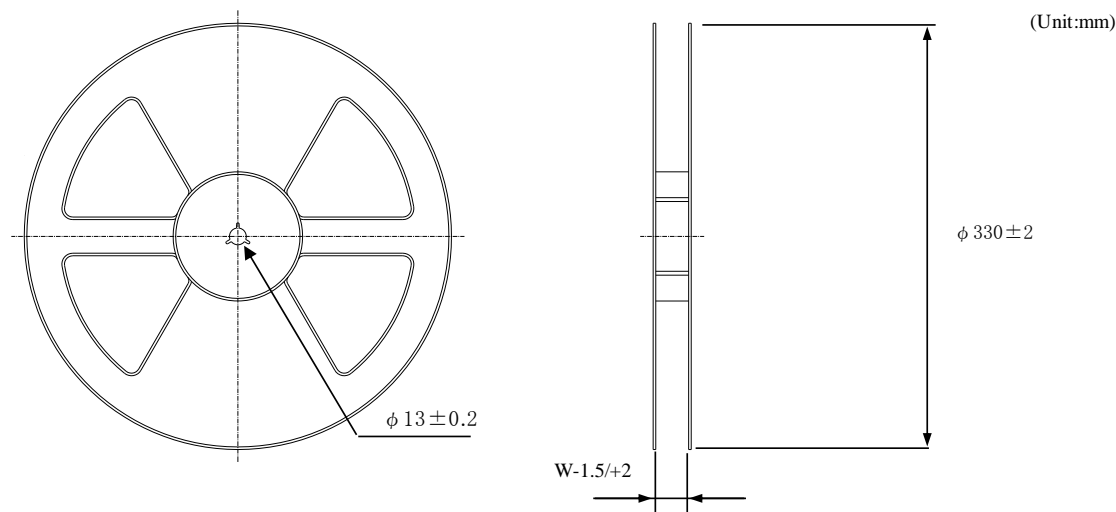

Tape wide	8mm	12mm	16mm	24mm	32mm	44mm
W	9.4mm	13.4mm	17.4mm	25.4mm	33.4mm	45.4mm

Taping performance
テーピング性能

Both of an embossing tape top cover tape bear this, when the power of 10N is applied in the direction of a drawer.
・エンボステープ、トップカバーテープともに、引き出し方向に10Nの力を加えた場合に、これに耐えること。

The exfoliation adhesion of a top cover tape is the intensity of 0.1~1.3N.
(The angle to pull is 165~180 degrees. The speed to pull is 300 mm/min.)

・トップカバーテープの剥離強度は、角度165~180度に保ち、300mm/minのスピードでトップカバーテープを引っ張ったとき、0.1~1.3Nとする。

Note
備考

Lack of the parts in 1 reel is with two or less pieces.

1リール中の部品の欠落は2個までとします。(ラベル表示数量と梱包数は同じです。欠落とはテープ内でのモジュール抜けが2個まで許容させていただくという意味になります。)

MSL Level 3 Under control

MSL はレベル3 で管理しています。

TAIYO YUDEN CO., LTD.

EYSGCNAWY-VX

TAIYO YUDEN CO., LTD.

Control No. (1/3)	Control name アンテナアプリケーションノート
----------------------	---------------------------------

メイン基板へのモジュール実装例 (当社推奨)

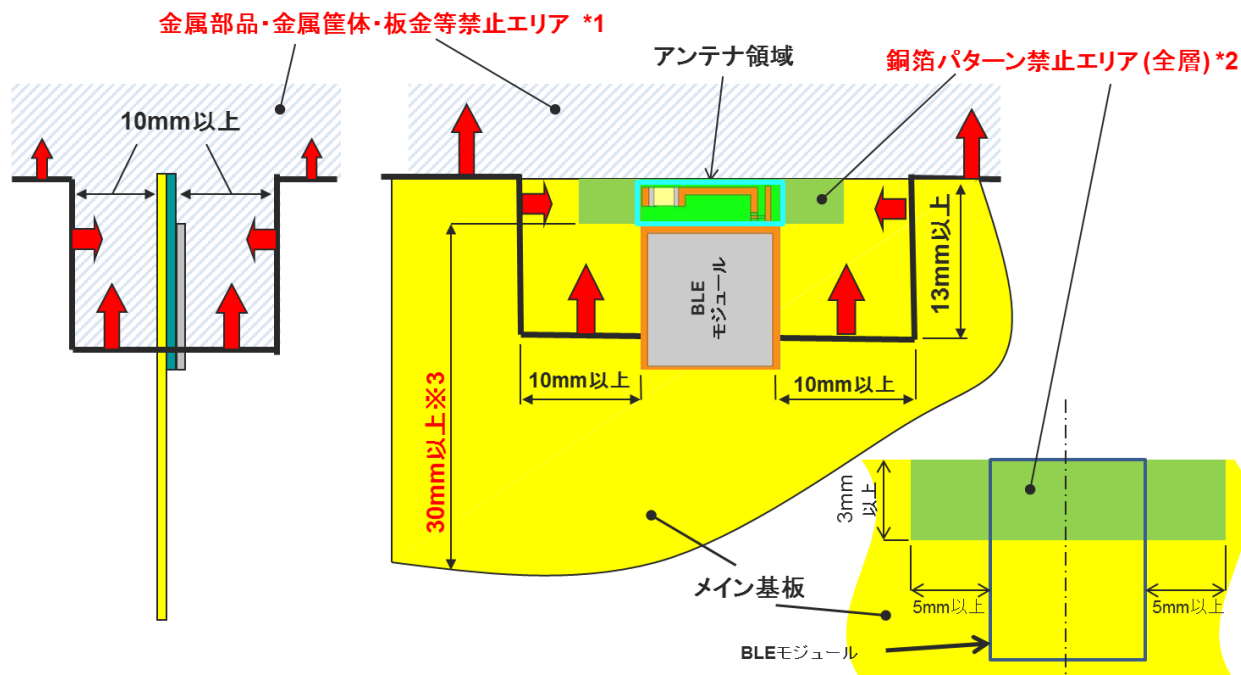

・赤矢印が指す斜線の空間内には、メイン基板以外の金属部品（配線、金属筐体、金属めっきの樹脂など）が無い様にしてください。但し、メイン基板上への部品実装は銅箔パターン禁止エリア(*2)を除き問題ありません。

・メイン基板上の GND パターン長(※3)が 30mm を下回るとアンテナ性能が低下しますので、できる限り 30mm 以上としてください。

・本条件を満足している場合でも、製品の構造によっては通信性能が著しく低下する場合があります。

EYSGCNAWY-VX

TAIYO YUDEN CO., LTD.

Control No. (2/3)	Control name アンテナアプリケーションノート
--------------------------	---------------------------------

その他の実装例

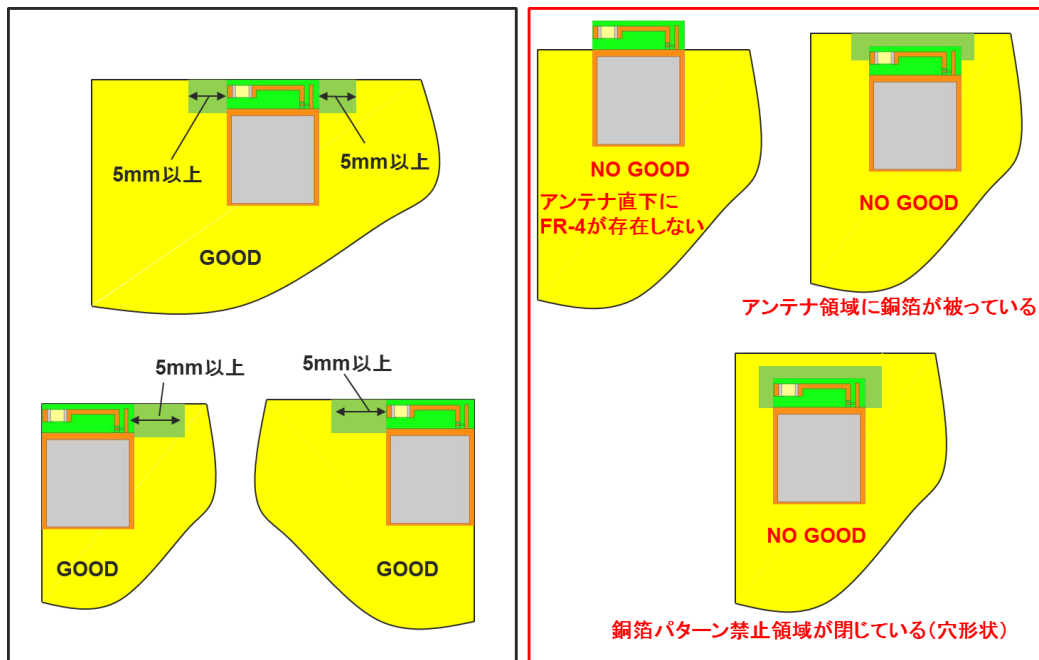

樹脂部品の配置について

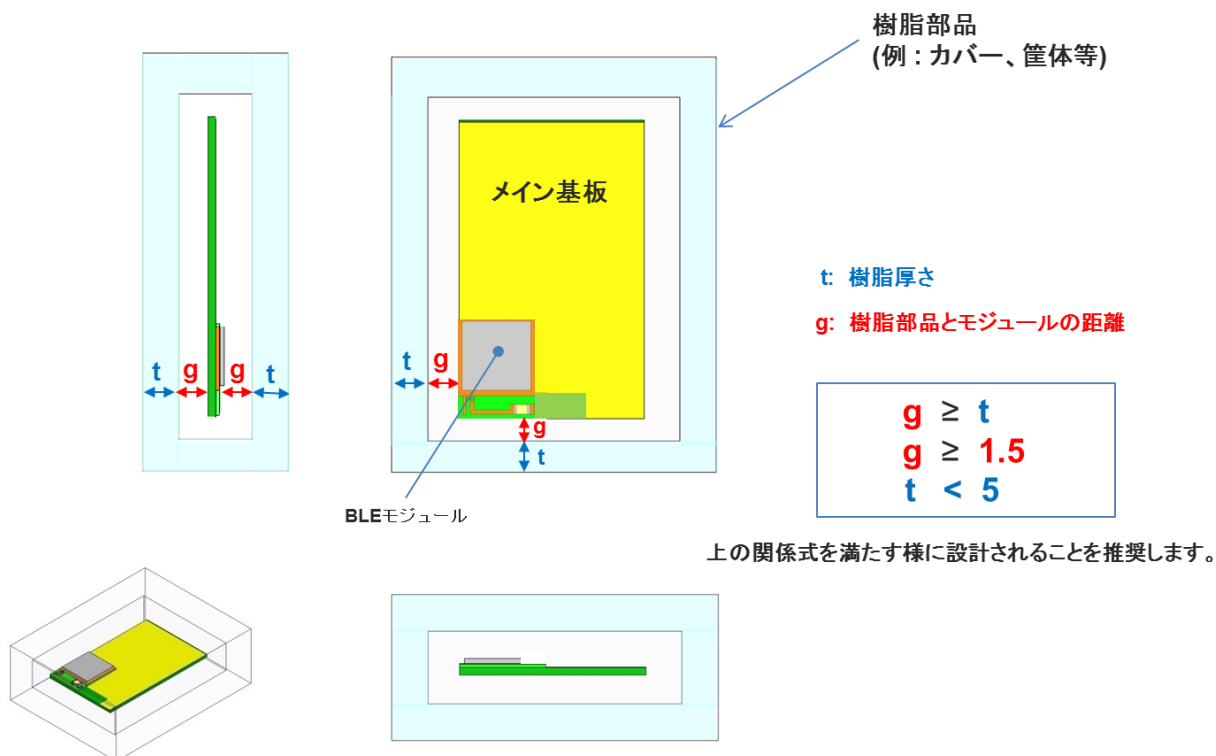

・BLEモジュールアンテナ部へのモールドは避けてください。

TAIYO YUDEN CO., LTD.

Control No.	Control name
(3/3)	アンテナアプリケーションノート

指向性特性例(評価基板実装時)

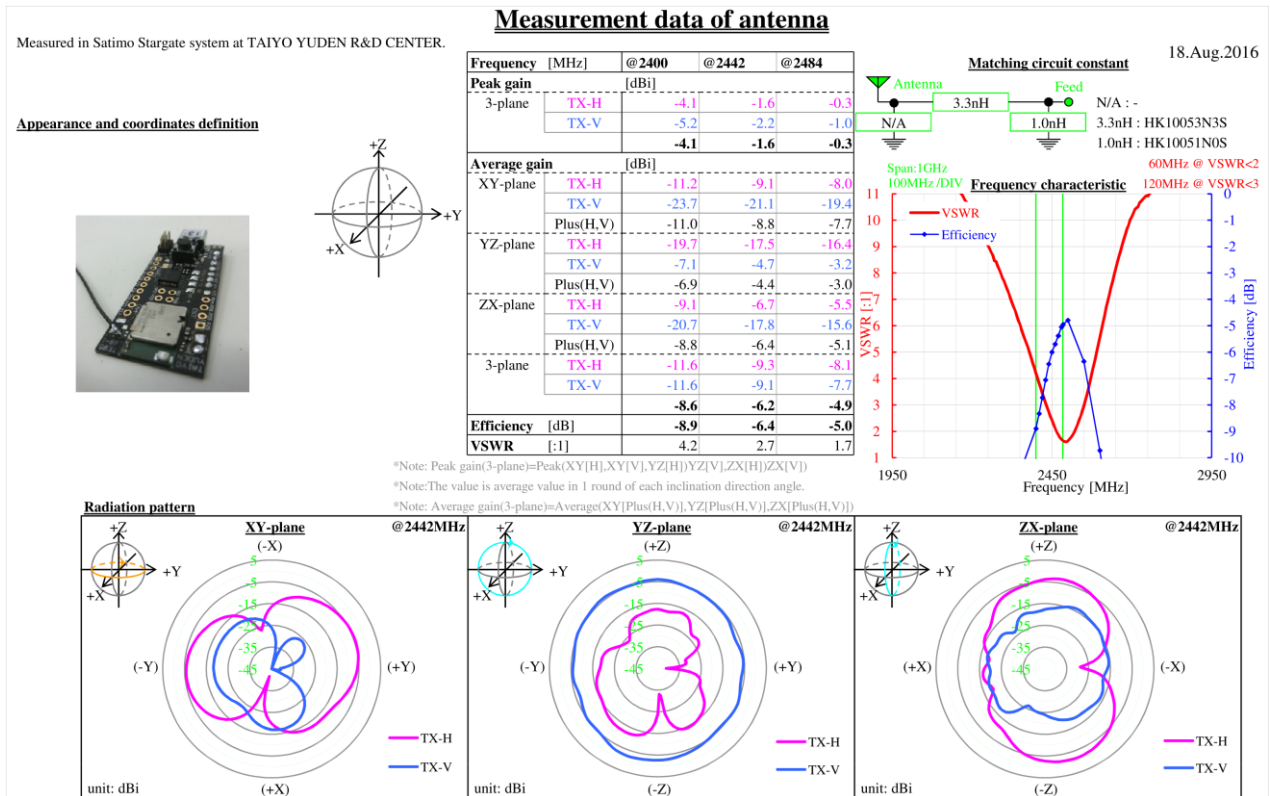

本資料について

- ・本アンテナアプリケーションノートは、BLE モジュールに搭載されているアンテナ特性をより良く確保するための参考資料です。通信性能・飛距離を確保・保証するものではありません。
- ・本製品は、BLE モジュールとして電波法認証を取得しておりますので、周囲環境の影響に合わせて、モジュール内のアンテナ用マッチング回路の定数を変更することはできません。変更した場合は、電波法認証を取り直す必要があります。

EYSGCNAWY-VX

TAIYO YUDEN CO., LTD.

Control No. (1/1)	Control name デザインガイド
----------------------	-------------------------

1. 電源起動シーケンス

VCC_NRFピンの立ち上がり時間 (0V から 1.8V) は100msを超えないで下さい。

2. 推奨電源回路

VCC_NRFはこのモジュールのメイン電源 (1.8 – 3.6V)です。VCC_NRFの電源電圧範囲はLDOモードでは1.8Vから3.6V、DCDCモードでは2.1Vから3.6Vです。内蔵DC/DCコンバータ動作に関するより詳細な情報は、Nordic Semiconductor社発行の"nRF51_Series_Reference_Manual v3.0"の12.1.3章をご参照下さい。負荷変動による電源電圧の変動が大きい場合、誤動作する可能性があります。外部レギュレータを使用する場合は、負荷変動に強いものを選定し、電流が変化した際に電圧が極力変動しないようご注意ください。

3. 電池動作

電源として小型電池 (例: CR2032)を使用する場合は、大容量コンデンサ (低漏れ電流の100uFコンデンサなど)を電池の近くに接続して下さい。低温時にモジュールを動作させる際に、負荷による電圧降下を軽減します。

4. パターン設計ガイド**4-1. 電源系**

電源のデカップリングコンデンサは、モジュールのVCC_NRFピンの直近に配置して下さい。VCC_NRFの配線は、幅0.5mm以上で、より大きな直径のビアを使って接続することを推奨します。

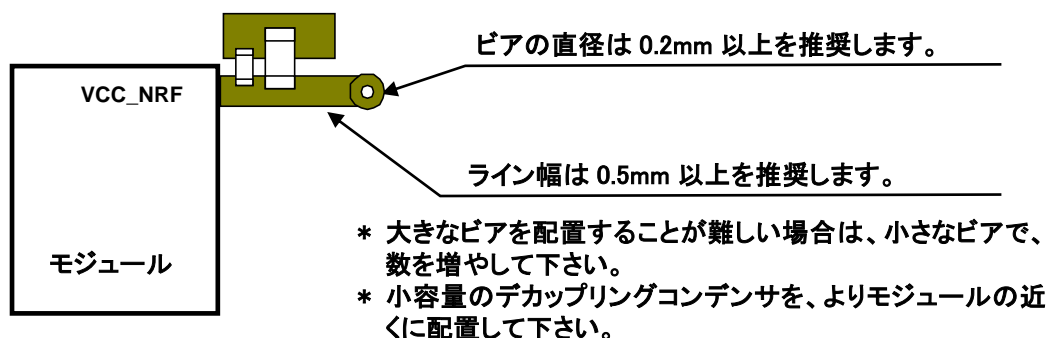
**4-2. デカップリングコンデンサ配置**

デカップリングコンデンサは、小容量コンデンサ (約10pF) と大容量コンデンサ (1uF から 10uF) を組み合わせて配置することを推奨します。デカップリングコンデンサのGNDはクローズドループが最小となるようにモジュールのGNDの直近に配置することを推奨します。

4-3. GND パターン

電源デカップリングコンデンサのGNDはモジュールGNDの近くに配置して下さい。各レイヤのアイソレーションを確保するために、なるべく広くGND層を取って下さい。

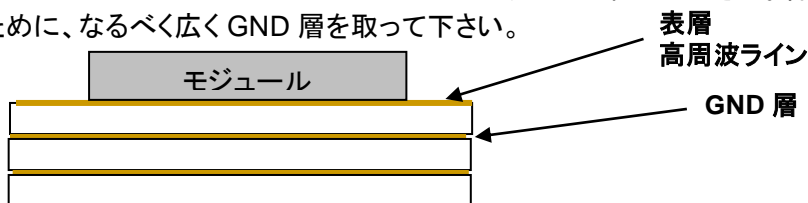

各層のGNDパターンは、多くのビアで内層のGND層に接続して下さい。

EYSGCNAWY-VX

TAIYO YUDEN CO., LTD.

Copyright Information:

- *Bluetooth*® low energy module Software -

This software is owned by TAIYO YUDEN CO., LTD.

You and your company shall conform following:

- (1) The software image may not be made a copy from TAIYO YUDEN CO., LTD.'s module.
- (2) The software image provided by TAIYO YUDEN CO., LTD. must not be loaded to another vendor's module or chipset, and can be copied only for backup.
- (3) The software image may not be provided to anyone.
- (4) The software image may not be analyzed by reverse engineering, decompile, and disassemble.

TAIYO YUDEN CO., LTD. is not responsible for any damage caused by this software.

Copyright Year 2015-

Firmware Version is Ver. 4.0.0

There is a possibility of changing a software specification.

Trademark:

- iBeacon is a trademark of Apple Inc.

TAIYO YUDEN CO., LTD.

EYSGCNAWY-VX

TAIYO YUDEN CO., LTD.

Contents

1. OVERVIEW	31
2. BASIC SOFTWARE STATE DIAGRAM	32
3. COMMAND SYNTAX	33
3.1 CONTROL COMMAND	33
3.2 DATA TRANSMISSION AND RECEPTION COMMAND	33
3.2.1. TRANSMISSION COMMAND	33
3.2.2. TRANSMISSION RESPONSE	33
3.2.3. RECEPTION EVENT	34
4. PERIPHERAL	35
4.1. CONTROL COMMAND AND EVENT LIST	35
4.1.1. COMMON COMMANDS	35
4.1.2. COMMON RESPONSE EVENTS	40
4.2. PERSISTENT STORE (PS) USER KEY DESCRIPTION	41
4.3. ERROR CODES	45
4.3.1. DISCONNECT REASON	45
4.4. MESSAGE SEQUENCE CHART	46
4.4.1. POWER ON (IN CASE OF PSKEY_USER01#'0000' AND PSKEY_USER07#'0000')	46
4.4.2. ADVERTISING START	46
4.4.3. ADVERTISING STOP	47
4.4.4. CONNECT	47
4.4.5. SENDING & RECEIVING DATA OVER A CONNECTED LINK	48
4.4.6. DISCONNECT	49
4.4.7. PAIRING	49
4.4.8. DIRECTED ADVERTISING	50
4.4.9. DISCONNECT REQUEST (GPIO)	51
4.4.10. DISCONNECT REQUEST (COMMAND)	52
4.5. GPIO STATE AND CONTROL	53
4.5.1. ADVERTISING	54
4.5.2. CONNECT	54
4.5.3. DISCONNECT & STANDBY	54
4.5.4. FORCED INITIALIZE	54
4.5.5. SLEEP MODE REQUEST AND INDICATE	55
4.6. SERVICE	56
4.7. UART CONFIGURATION	56
4.8. SWD (SERIAL WIRE DEBUG)	56
4.9. HOST WAKE-UP SEQUENCE	57
4.10. DTM (DIRECT TEST MODE)	58
4.10.1. ENTER DTM AND EXIT DTM WITH GPIO	58
4.10.2. ENTER DTM AND EXIT DTM WITH UART COMMAND (PERMANENT)	59
4.10.3. ENTER DTM AND EXIT DTM WITH COMMAND	60
4.10.4. DTM COMMANDS/EVENTS	60

TAIYO YUDEN CO., LTD.

EYSGCNAWY-VX

TAIYO YUDEN CO., LTD.

4.11. GPIO CHECK	61
4.12. SLEEP MODE (SYSTEM ON).....	62
4.12.1. ENTER SLEEP MODE.....	62
4.12.2. EXIT SLEEP MODE.....	62
4.13. POWER SAVING MODE (SYSTEM OFF).....	63
4.13.1. ON STARTUP (IN CASE OF PSKEY_USER09='0001')	63
4.13.2. BSP COMMAND	63
4.14. DEVICE FIRMWARE UPDATES (DFU)	64
4.15. IDENTIFY THE PEER DEVICE	65
4.15.1. PAIRING.....	65
4.15.2. CONNECTION	66
4.16. CUSTOMIZED ADVERTISING DATA.....	67
4.17. LE SECURE CONNECTION	68
4.18. NOTICES.....	73
5. CENTRAL.....	74
5.1. CONTROL COMMAND AND EVENT LIST	74
5.1.1. COMMON COMMANDS.....	74
5.1.2. COMMON RESPONSE EVENTS.....	78
5.2. PERSISTENT STORE (PS) USER KEY DESCRIPTION	79
5.3. ERROR CODES	85
5.3.1. DISCONNECT REASON	85
5.4. MESSAGE SEQUENCE CHART.....	86
5.4.1. POWER ON (IN CASE OF PSKEY_USER01≠'0000' AND PSKEY_USER07≠'0000')	86
5.4.2. SCAN START.....	86
5.4.3. SCANNING STOP.....	87
5.4.4. CONNECT	87
5.4.5. SENDING & RECEIVING DATA OVER A CONNECTED LINK.....	88
5.4.6. DISCONNECT	89
5.4.7. PAIRING.....	90
5.4.8. DISCONNECT REQUEST (GPIO)	91
5.4.9. DISCONNECT REQUEST (COMMAND)	91
5.5. GPIO STATE AND CONTROL	92
5.5.1. DISCONNECT REQUEST.....	93
5.5.2. CONNECTED.....	93
5.5.3. DISCONNECT & STANDBY	93
5.5.4. FORCED INITIALIZE	93
5.5.5. SLEEP MODE REQUEST AND INDICATE	93
5.6. SERVICE.....	94
5.7. UART CONFIGURATION	94
5.8. SWD (SERIAL WIRE DEBUG)	94
5.9. HOST WAKE-UP SEQUENCE	95
5.10. DTM (DIRECT TEST MODE)	96

TAIYO YUDEN CO., LTD.

5.10.1. ENTER DTM AND EXIT DTM (ONE-TIME)	96
5.10.2. ENTER DTM AND EXIT DTM WITH UART COMMAND (PERMANENT)	97
5.10.3. ENTER DTM AND EXIT DTM WITH GPIO COMMAND (PERMANENT)	98
5.10.4. DTM COMMANDS/EVENTS	98
5.11. GPIO CHECK	99
5.12. SLEEP MODE (SYSTEM ON)	100
5.12.1. ENTER SLEEP MODE	100
5.12.2. EXIT SLEEP MODE	100
5.13. POWER SAVING MODE (SYSTEM OFF)	101
5.13.1. ON STARTUP (IN CASE OF PSKEY_USER09='0001')	101
5.13.2. BSP COMMAND	101
5.14. DEVICE FIRMWARE UPDATES (DFU)	102
5.15. RSSI AND ADVERTISING DATA NOTIFICATION	103
5.16. FILTER	104
5.16.1 PSKEY	104
5.16.2 STF COMMAND	104
5.16.3 GTF COMMAND	106
5.17. LE SECURE CONNECTION	107
5.18. NOTICES	112

1. Overview

This specification is for module based on TAIYO YUDEN original service. This specification will only define supporting point-to-point connections.

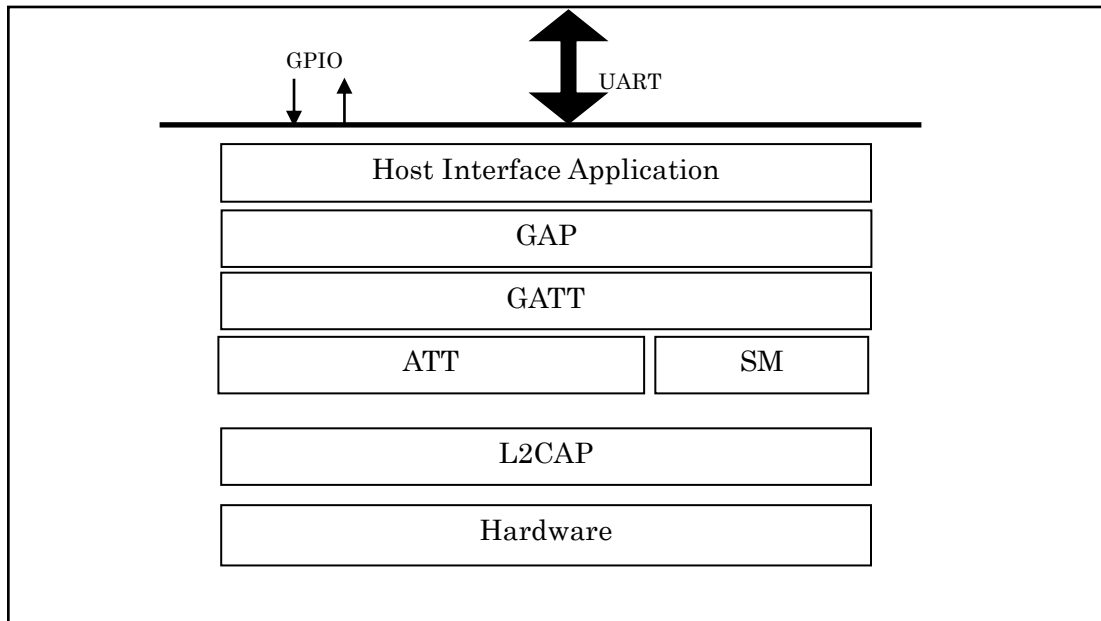

Software Block Diagram

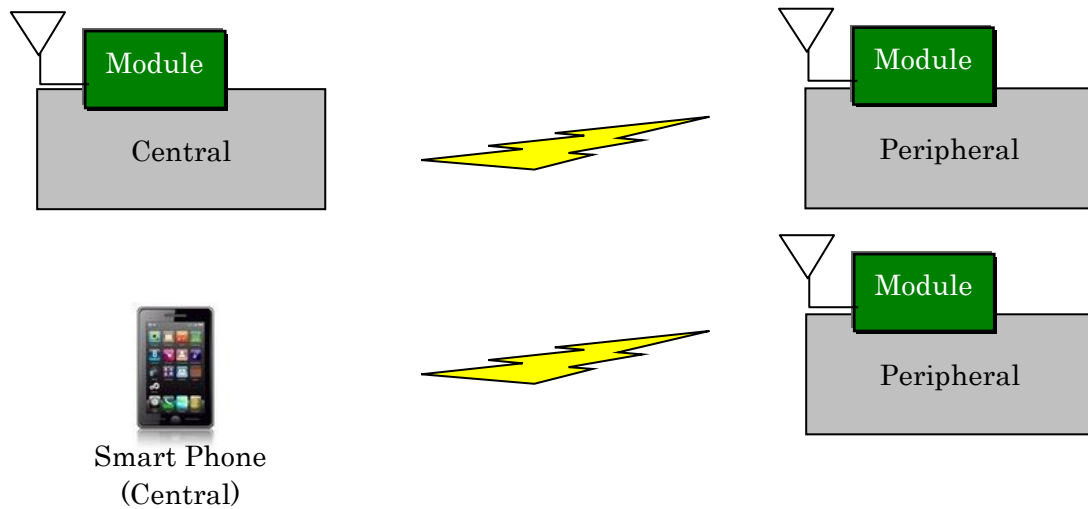

Usage Model

* Only one-to-one connection is supported.

2. Basic software state diagram

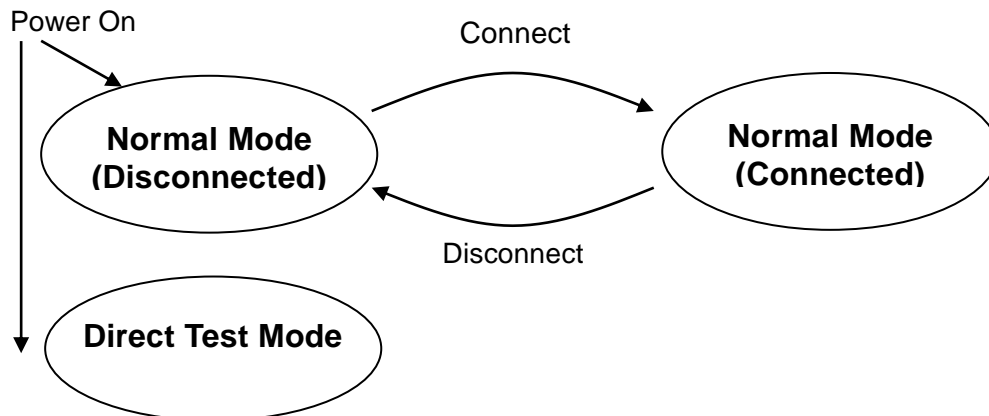

- **Normal Mode (Disconnected) :**
Module can only accept control commands in this mode.
- **Normal Mode (Connected) :**
Module can accept control commands and data transmission command in this mode. When disconnected, it will return to Normal Mode (Disconnected).
- **Direct Test mode :**
RF PHY testing of *Bluetooth*® low energy devices.

3. Command Syntax

3.1 Control Command

Control commands which the host sends are based on character strings that start with “B”(ASCII code: 0x42, 66 decimal), and that end with <CR><LF> (ASCII code: 0x0D 0x0A) (decimal values 13, 10).

Response event which host receives are started with <CR><LF> and ended <CR><LF>. Please note that this specification / application does not allow for multiple commands to be sent to the host. The application is not responsible for parsing of packets / command sequences.

Command Mode – Control Command:

“B”{command characters}[Parameter1Parameter2:: Parameter(N)]<CR><LF>

Response Event:

<CR><LF>{event characters}[Parameter1Parameter2::Parameter(N)]<CR><LF>

3.2 Data Transmission and Reception Command

3.2.1. Transmission Command

B	SEND	,	Index	Method	Length	Data
	CMD				PARAM	

“BSEND,” : 6byte - ascii

Index : 1byte - binary

0 : In Peripheral role

1 : In Central role

Method : 1byte - binary

0 : Notification, Write Command

1 : Indication, Write Request

2 : Battery Service (Peripheral only, Send first byte of data as battery level)

Length : 1byte - binary

1 - 20 (0x01 - 0x14)

Data : 1-20byte (specified at Length param) - binary

3.2.2. Transmission Response

B	SEND	,	Response code	¥r	¥n
	RES		PARAM	CR	LF

Response code : ascii

“ACK” : Successful

“NAKx” : Failed

x=01 Bad parameter

x=02 Disconnected

x=03 Service disabled

x=04 In sending

x=05 Send data error

EYSGCNAWY-VX

TAIYO YUDEN CO., LTD.

x=06 Same data (Battery Service only)

- Data transmission command shall be sent after previous command response.
- In Method = 0 and 1, Characteristic value is updated even when data is failed to be sent in error NAK02-NAK05.
- In Method = 2, Characteristic value is updated even when data is failed to be sent in error NAK05.

3.2.3. Reception Event

B	RECV	,	RSSI	Index	Method	Length	Data
	CMD				PARAM		

“BRCV,” : 6byte – ascii

RSSI : 1byte – binary

-128 - 127 (0x80 – 0x7F : two’s complement)

Index : 1byte - binary

0 : In Peripheral role

1 : In Central role

Method : 1byte - binary

0 : Notification, Write Command

1 : Indication, Write Request

Length : 1byte - binary

1 - 20 (0x01 - 0x14)

Data : 1-20byte (specified at Length param) - binary

EYSGCNAWY-VX

TAIYO YUDEN CO., LTD.

4. Peripheral

4.1. Control Command and Event List

4.1.1. Common Commands

Command Character	Function	Parameter	Response
Configuration These commands are available when advertising stopped.			
ST1	Set initiator's address in Direct Advertising. "BST1112233445566"	<u>Parameter:</u> BD Address	Successful: ACK Failed: NAK##
ST2	Set Local device address "BST2F01234AABBCC" It will return to the initial value when reset. PSKEY_USER10 shall be set to 0000.	<u>Parameter:</u> BD Address (Static Address)	Successful: ACK Failed: NAK##
ST3	Set Local Device Name (MAX 16CHARACTERS) Default : "TYSA-B 4.0.0" The setting will be updated after reset.	<u>Parameter:</u> Device_name	Successful: ACK Failed: NAK##
ST4	Set default value for User data The setting will be updated after reset. User data is PSKEY, Bonding information and Advertising data. Please refer section 4.2 about PSKEY. Baudrate setting is not initialized.	/	Successful: ACK Failed: NAK##
ST5	Set PSKEY Value (Note Values 0 >= are valid) Example BST5030100 (set PSKEY 03 to 0x0100) The setting will be updated after reset. Please refer section 4.2.	<u>Parameter 0:</u> PSKEY: DD (Decimal) <u>Parameter 1:</u> Value: HHHH (Hex Word)	Successful: ACK Failed: NAK##

EYSGCNAWY-VX

TAIYO YUDEN CO., LTD.

ST8	<p>Set Customized Advertising data (MAX 62CHARACTERS (31bytes))</p> <p>The data is stored in FLASH.</p> <p>Example BST801EFFFFFFFFFFFFFFFFFFFFFFF FFFFFFFFFFFFFFFFFFFFFFFFFFFFFFF FFFFFFFFF (Advertising data : 0x1E,0xFF...)</p> <p>BST811EFFFFFFFFFFFFFFFFFFFFFFF FFFFFFFFFFFFFFFFFFFFFFFFFFFFFFF FFFFFFFFF (Scan Response data : 0x1E,0xFF...)</p> <p>Please refer section 4.16 for details.</p> <p>The data will be updated in next "CD" command.</p>	<p><u>Parameter 0:</u> Advertising : 0 Scan Response : 1</p> <p><u>Parameter 1:</u> data: HHHH... (Hex ASCII)</p>	<p>Successful: ACK Failed: NAK##</p>
ST9	<p>Set Customized Advertising data (MAX 62CHARACTERS (31bytes))</p> <p>The data is not stored in FLASH.</p> <p>Example BST901EFFFFFFFFFFFFFFFFFFFFFFF FFFFFFFFFFFFFFFFFFFFFFFFFFFFFFF FFFFFFFFF (Advertising data : 0x1E,0xFF...)</p> <p>BST911EFFFFFFFFFFFFFFFFFFFFFFF FFFFFFFFFFFFFFFFFFFFFFFFFFFFFFF FFFFFFFFF (Scan Response data : 0x1E,0xFF...)</p> <p>Please refer section 4.16 for details.</p> <p>The data will be updated in next "CD" command.</p>	<p><u>Parameter 0:</u> Advertising : 0 Scan Response : 1</p> <p><u>Parameter 1:</u> data: HHHH... (Hex ASCII)</p>	<p>Successful: ACK Failed: NAK##</p>

EYSGCNAWY-VX

TAIYO YUDEN CO., LTD.

GT2	Read Local BD Address		Successful: Local BD_ADDR, ACK Failed: NAK##
GT3	Read Local Device Name		Successful: Local Device Name, ACK Failed: NAK##
GT5	Read PSKEY Value Example: BGT501 (Get PSKEY 1)		Successful: KVHHHH, ACK Failed: NAK##
GT6	Read Paired Initiator's BD Address and IRK (Initiator = Central side) From top to bottom, index 1 to 7 are assigned for DS command.		Successful: Initiator's BD Address, IRK, ACK Failed: NAK##
GT8	Get Customized Advertising data	<u>Parameter 0:</u> Advertising : 0 Scan Response : 1	Successful: HHHH... (Hex ASCII) Stored Advertising data
GT9	Get Customized Advertising data	<u>Parameter 0:</u> Advertising : 0 Scan Response : 1	Successful: HHHH... (Hex ASCII) Current Advertising data
DS	Delete a Specified Paired Central device.	<u>Parameter:</u> 1-7 : index Please refer GT6 command.	Successful: ACK Failed: NAK##
DD	Delete all Paired Central devices		Success: ACK Failed: NAK##
TT	Go to Direct Test Mode		Successful: ACK Failed: NAK##
SP	Go to Power saving mode		Failed: NAK##
RS	Reset the module		Successful: Ver. XXXX Failed: NAK##
RL	Role switch The setting will be updated after reset.	<u>Parameter:</u> 0 : Peripheral 1 : Central	Successful: ACK Failed: NAK##

TAIYO YUDEN CO., LTD.

EYSGCNAWY-VX

TAIYO YUDEN CO., LTD.

Link Control			
CD	<p>Connectable & Discoverable (Advertising Start / Stop)</p> <p>Advertising PDU type '1' - '2': ADV_IND Connectable and Scannable. Allow Scan Request from Any, Allow Connect Request only from White List.</p> <p>'3' - '4': ADV_IND Connectable, Scannable and Discoverable from any devices.</p> <p>'5' : ADV_DIRECT_IND Connectable from the device whose BD Address matches ST1 command.</p> <p>'6' : ADV_NONCONN_IND Non-Connectable, Non-Scannable and Discoverable.</p> <p>'7' : ADV_SCAN_IND Non-Connectable, Scannable and Discoverable.</p> <p>Default data Advertising : 0D09545953412D4220332E302E3 0 020105020A04</p> <p>Scan Response : 03030F181107EB532D21D4E1E1 CB 289A008A70152F44</p>	<p><u>Parameter</u> '0' – Advertising Stop.</p> <p>'1' – Connectable from White List Advertising Start. Default data.</p> <p>'2' – Connectable from White List Advertising Start. Customized data.</p> <p>'3' – Connectable and discoverable from any devices Advertising Start. Default data.</p> <p>'4' – Connectable and discoverable from any devices Advertising Start. Customized data.</p> <p>'5' – Directed Advertising Start.</p> <p>'6' – Non-Connectable and Non-Scannable Advertising Start. Customized data.</p> <p>'7' – Non-Connectable and Scannable Advertising Start. Customized data.</p>	<p>Successful: ACK, Failed: NAK##</p>

TAIYO YUDEN CO., LTD.

EYSGCNAWY-VX

TAIYO YUDEN CO., LTD.

DC	Disconnect		Successful: ACK, DCO Failed: NAK##
IO	Local Device I/O capabilities 0: Display only. (Passkey Entry) 1: Display and enter "yes" or "no". (Numeric Comparison) 2: Keyboard only. (Passkey Entry) 3: No Input and No Display. (Just Works) 5: Out of Band (OOB) (Default is '3') The setting will be updated after reset.	<u>Parameter</u> I/O capabilities (['0','1','2','3','5'])	Successful: ACK, Failed: NAK##
YN	Answer of numeric collation	<u>Parameter</u> Yes/No '0' – Yes, Accept '1' – No, Reject	Successful: PS,CON Failed:NAK##
KY	Enter the passkey number (Six digit number) Example: BKY895361	Passkey (ASCII) (from "000000" to "999999")	Successful: PS,CON Failed:NAK##
OB	Read Local OOB Data		Successful: OBC 32CHARACTERS OBR 32CHARACTERS Failed: NAK##
OC	Remote OOB Data (Simple Pairing Hash C) 32CHARACTERS	OOB (ASCII) (from "00000000000000000000000000000000" " to "FFFFFFFFFFFFFFFFFFFFFFFFFFFFFFFF FFF")	Successful: ACK Failed: NAK##
OR	Remote OOB Data (Simple Pairing Randomizer R) 32CHARACTERS	OOB (ASCII) (from "00000000000000000000000000000000" " to "FFFFFFFFFFFFFFFFFFFFFFFFFFFFFFFF FFF")	Successful: ACK Failed: NAK##

EYSGCNAWY-VX

TAIYO YUDEN CO., LTD.

4.1.2. Common Response Events

Response Events	Function	Parameters
ACK	Successful	
NAK##	Failed	Failed Reason – See Error section 4.3. for further details.
CON	Connection successful	Established Remote BD_ADDR
DCO	Disconnect	<u>Parameter 0:</u> 0 : In Peripheral role 1 : In Central role <u>Parameter 1:</u> Reason in hexadecimal See section 4.3.1 for further details.
ADT	Advertising Timeout	
PAS	Pairing Success	<u>Parameter:</u> 0 : Paired device is not stored 1-7 : Index of paired device list
ESR	Enable Service	<u>Parameter:</u> 0 : Characteristic 0x1571 (Notification) 1 : Characteristic 0x1573 (Indication) 2 : Battery Service
DSR	Disable Service	<u>Parameter:</u> 0 : Characteristic 0x1571 (Notification) 1 : Characteristic 0x1573 (Indication) 2 : Battery Service
NM	Shown a six digit number (Numeric Value)	<u>Parameter:</u> From "000000" to "999999" (ASCII)
OBC	Local OOB Data (Simple Pairing Hash C)	<u>Parameter:</u> From "00000000000000000000000000000000" to "FFFFFFFFFFFFFFFFFFFFFFFFFFFFFFFF" (ASCII)
OBR	Local OOB Data (Simple Pairing Randomizer R)	<u>Parameter:</u> From "00000000000000000000000000000000" to "FFFFFFFFFFFFFFFFFFFFFFFFFFFFFFFF" (ASCII)
KEY	Request passkey number	
PK	Passkey Number indication	<u>Parameter:</u> From "000000" to "999999" (ASCII)

TAIYO YUDEN CO., LTD.

EYSGCNAWY-VX

TAIYO YUDEN CO., LTD.

4.2. Persistent Store (PS) User Key Description

All Values for "Defaults" are in HEX notation.

Name	PSKEY_USER00	Key Length:	1
Descriptive Name:	Baud rate		
Description:	Set Session Baud Rate. (bps) 0001: 9600, 0002: 19200, 0003: 38400, 0004: 57600, 0005: 115200 0006: 230400, 0007: 460800, 0008: 921600		
Default:	0001 (9600bps)		
Range	0001 - 0008		

Name	PSKEY_USER01	Key Length:	1
Descriptive Name:	Advertising Timeout (sec)		
Description:	Advertising Timeout defines the timeout for the advertising. 0000 means timeout is disabling. Advertising will continue forever.		
Default:	003C (60sec)		
Range	0000 – 00B4 (0 – 180sec)		

Name	PSKEY_USER02	Key Length:	1
Descriptive Name:	Advertising Interval (msec)		
Description:	The time between the start of two consecutive advertising events. The value in this parameter is multiplied by 0.625msec.		
Default:	0040 (40msec)		
Range	0020 – 4000 (20 – 10240msec)		

Name	PSKEY_USER03	Key Length:	1
Descriptive Name:	Connection Interval Minimum (msec)		
Description:	Defines minimum value for the connection interval. The value in this parameter is multiplied by 1.25msec.		
Default:	0050 (100msec)		
Range	0006 – 0C80 (7.5 – 4000msec)		

EYSGCNAWY-VX

TAIYO YUDEN CO., LTD.

Name	PSKEY_USER04	Key Length:	1
Descriptive Name:	Connection Interval Maximum (msec)		
Description:	Defines maximum value for the connection interval. The value in this parameter is multiplied by 1.25msec.		
Default:	00A0 (200msec)		
Range	0006 – 0C80 (7.5 – 4000msec)		

Name	PSKEY_USER05	Key Length:	1
Descriptive Name:	Slave latency		
Description:	Defines the slave latency for the connection in number of connection events. The Slave Latency field shall have a value in the range of 0 to ((SupervisionTimeout / connectionIntervalMax*2) -1). The Slave Latency field shall be less than 500.		
Default:	0000		
Range	0000 – 01F3 (0 – 499)		

Name	PSKEY_USER06	Key Length:	1
Descriptive Name:	Supervision Timeout (msec)		
Description:	Defines the connection supervision timeout. The value in this parameter is multiplied by 10msec.		
Default:	01F4 (5000msec)		
Range	000A– 0C80 (100 – 32000msec)		

Name	PSKEY_USER07	Key Length:	1
Descriptive Name:	Auto Advertising Start setting		
Description:	This will store Auto Advertising Start at startup or disconnected setting. The parameter is correspond to that of CD command. “0000” : Auto start OFF “0001” : Auto start, Default Advertising data, ADV_IND (white list) “0002” : Auto start, Customized Advertising data, ADV_IND (white list) “0003” : Auto start, Default Advertising data, ADV_IND “0004” : Auto start, Customized Advertising data, ADV_IND “0006” : Auto start, Customized Advertising data, ADV_NONCONN_IND “0007” : Auto start ON, Customized Advertising data, ADV_SCAN_IND		
Default:	0000		
Range	0000– 0007 (0005 is not available)		

TAIYO YUDEN CO., LTD.

EYSGCNAWY-VX

TAIYO YUDEN CO., LTD.

Name	PSKEY_USER08	Key Length:	1
Descriptive Name:	Security setting		
Description:	This will store Security setting. "0000" will disable Security setting. "0001" will enable Security setting (LE Security Mode1, Level 2). "0002" will enable Secure Connection (LE Security Mode1, Level 4)		
Default:	0000		
Range	0000– 0002		

Name	PSKEY_USER09	Key Length:	1
Descriptive Name:	Power saving mode setting at startup.		
Description:	This will store Power saving mode setting at startup. "0000" will disable Power saving mode. It does not enter Power saving mode. "0001" will enable Power saving mode. It enters Power saving mode. Regardless of the setting, module can enter the mode by BSP command.		
Default:	0000		
Range	0000– 0001		

Name	PSKEY_USER10	Key Length:	1
Descriptive Name:	BD Address type		
Description:	Set the type of BD Address "0000": Static Address "0001" – "000F" : Resolvable Private Address The value in this parameter is multiplied by 60sec and used as address update interval. (1minite – 15minites)		
Default:	0000		
Range	0000– 000F		

Name	PSKEY_USER11	Key Length:	1
Descriptive Name:	Add the "peer device identify" to connection event.		
Description:	It can identify the peer device based on the IRK index. "0000" will disable identify. "0001" will enable identify. Please refer section 4.15 for details.		
Default:	0000		
Range	0000– 0001		

TAIYO YUDEN CO., LTD.

EYSGCNAWY-VX

TAIYO YUDEN CO., LTD.

Name	PSKEY_USER12	Key Length:	1
Descriptive Name:	TX power setting.		
Description:	Set the radio's transmit power. Radio transmit power in dBm (accepted values are -30, -20, -16, -12, -8, -4, 0, and 4 dBm). 0000: 4, 0001: 0, 0002: -4, 0003: -8, 0004: -12, 0005: -16, 0006: -20, 0007: -30		
Default:	0000		
Range	0000– 0007		

Name	PSKEY_USER13	Key Length:	1
Descriptive Name:	DC/DC converter setting		
Description:	DC/DC converter setting. "0000" will disable internal DC/DC converter (and use internal LDO). "0001" will enable internal DC/DC converter. Note: When supply voltage goes below 2.1V, DCDC is disabled, and enabled when the supply voltage goes up again. About hardware specification, please refer to "DataReport".		
Default:	0000		
Range	0000– 0001		

Name	PSKEY_USER14	Key Length:	1
Descriptive Name:	-		
Description:	Not use this user key. This value should be 0000.		
Default:	0000		
Range	0000		

EYSGCNAWY-VX

TAIYO YUDEN CO., LTD.

4.3. Error Codes

#	Error Name	Program Logic Cause / Action taken by Host
-1	Unknown Error	There is the possibility that the hardware is out of order.
00	Command Not Recognized	It confirms whether or not the command is correct.
01	Bad Parameter	It confirms parameter range.
02	Invalid State	Stop Advertising / Scanning or Disconnect.
04	UART Buffer full (buffer size : 128byte)	The commands shall be sent after previous command response.
05	Connection Fail (Central Only)	Please try again. If bond information exists, delete it and try again.
06	Device Full	Flash block for storing pairing information is full. (Max 7) To store new device information, delete with BDD command.
07	Pairing Failed	Please try again. If bond information exists, delete it and try again.
08	FLASH access error	Please run forced initialize (4.5.4).
11	Connection Parameter Error	It confirms connection parameter. Check PSKEY settings.
21	Advertising Parameter Error (Peripheral Only)	It confirms advertising data and parameter. Check PSKEY setting. If Advertising data is customized, check the parameter and the response of ST9 command.
22	Whitelist Error	It confirms whether or not bonded devices exist.
31	Scanning Parameter Error (Central Only)	It confirms scanning parameter. Check PSKEY setting.

4.3.1. Disconnect reason

#	Error Name	Description
08	BLE_HCI_CONNECTION_TIMEOUT	Connection Timeout.
13	BLE_HCI_REMOTE_USER_TERMINATED_CONNECTION	Remote User Terminated Connection.
16	BLE_HCI_LOCAL_HOST_TERMINATED_CONNECTION	Local Host Terminated Connection.
3D	BLE_HCI_CONN_TERMINATED_DUE_TO_MIC_FAILURE	Connection Terminated due to MIC Failure.

About other error codes, please see below.

https://infocenter.nordicsemi.com/topic/com.nordic.infocenter.s130.api.v2.0.1/group_ble_hci_status_codes.html

EYSGCNAWY-VX

TAIYO YUDEN CO., LTD.

4.4. Message Sequence Chart

4.4.1. Power On (In case of PSKEY_USER01#'0000' and PSKEY_USER07#'0000')

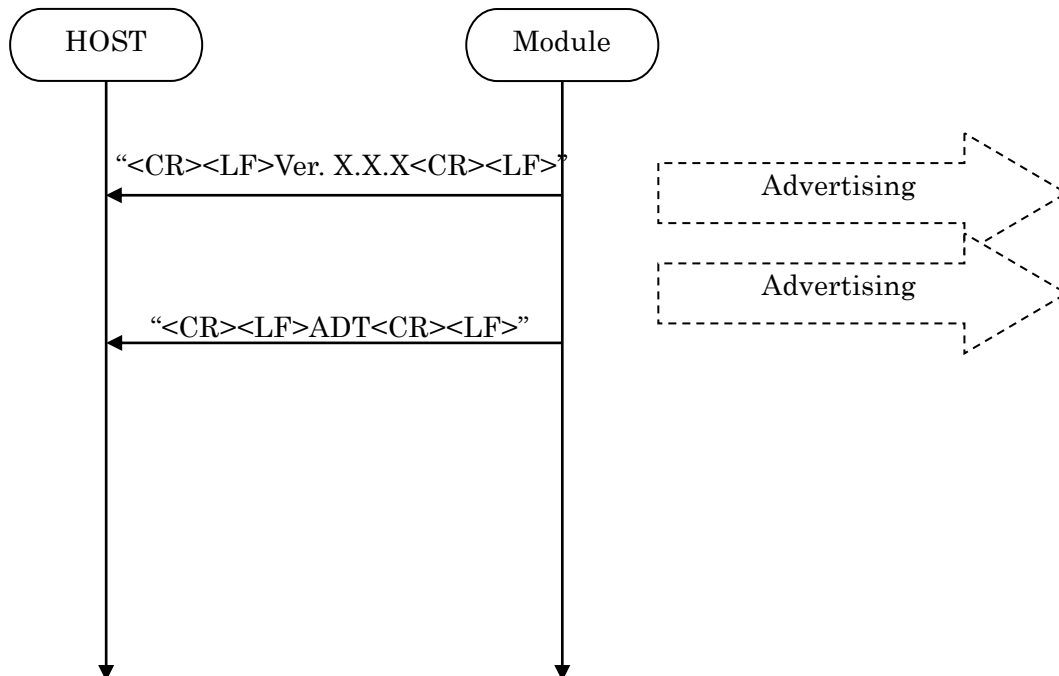

4.4.2. Advertising Start

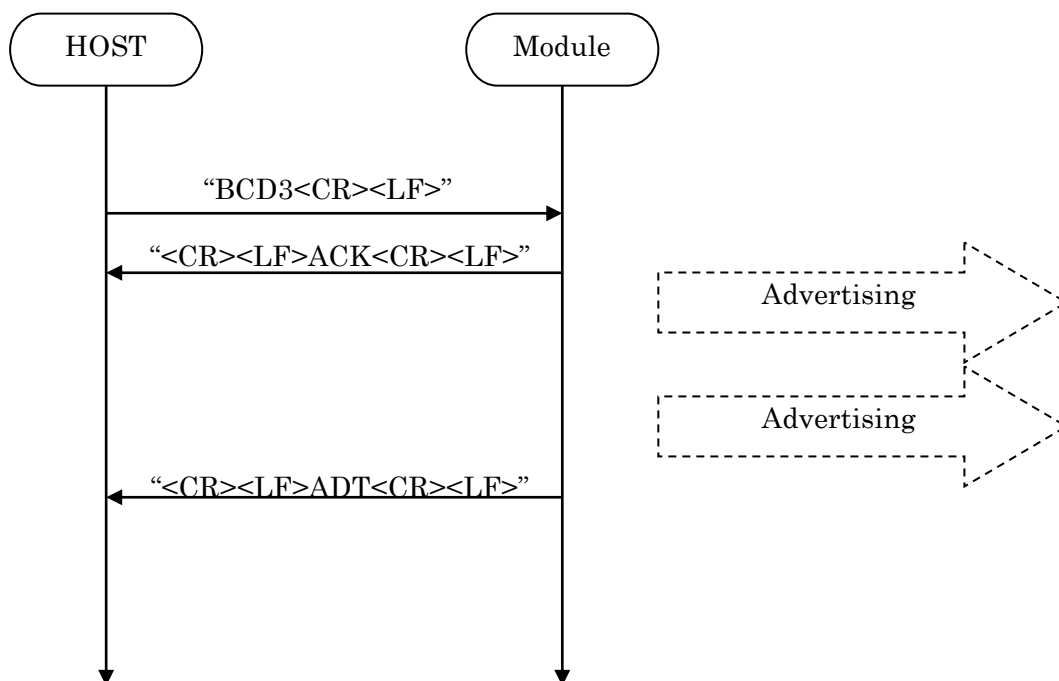

EYSGCNAWY-VX

TAIYO YUDEN CO., LTD.

4.4.3. Advertising Stop

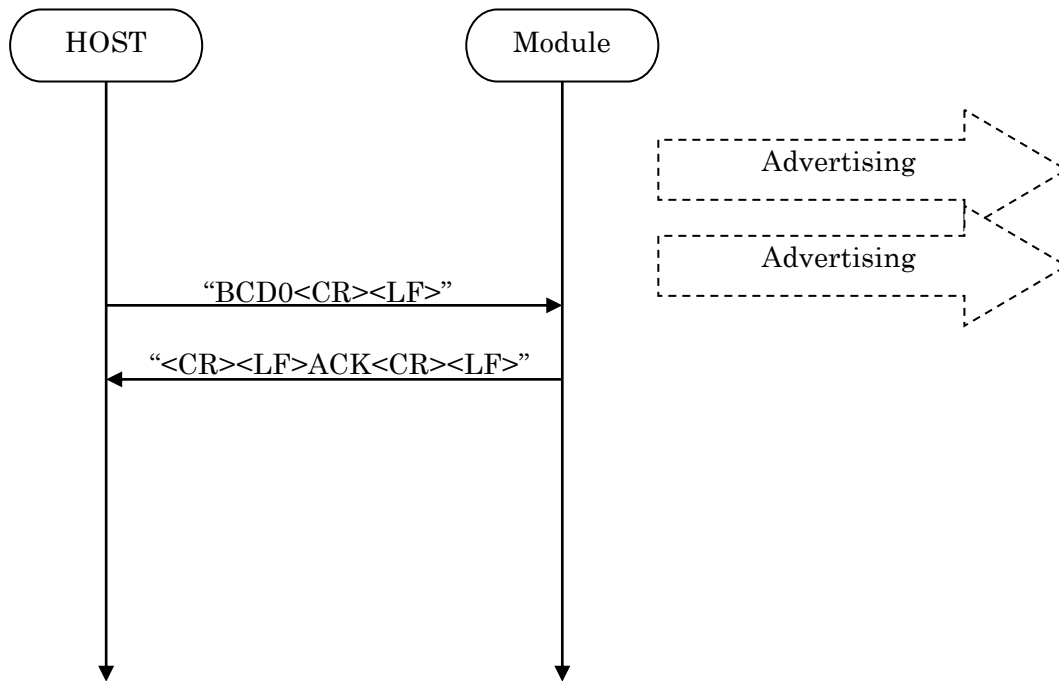

4.4.4. Connect

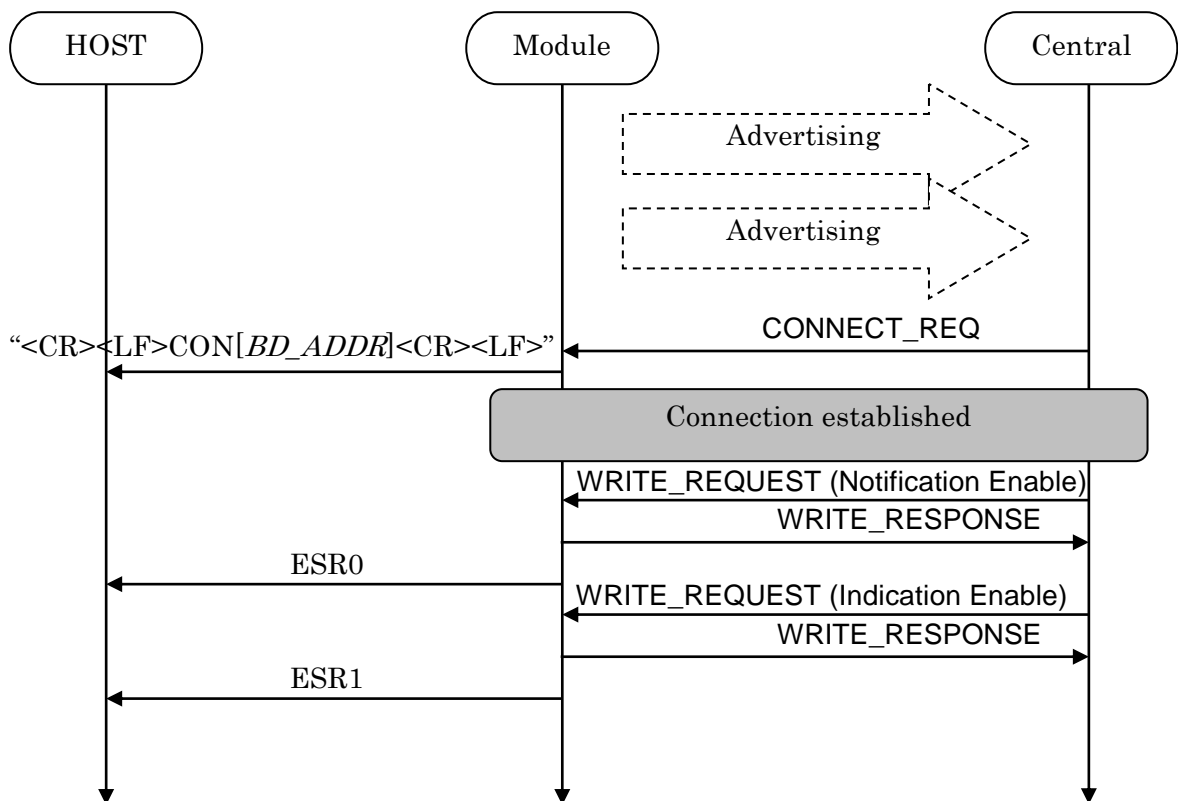

4.4.5. Sending & Receiving Data over a connected Link

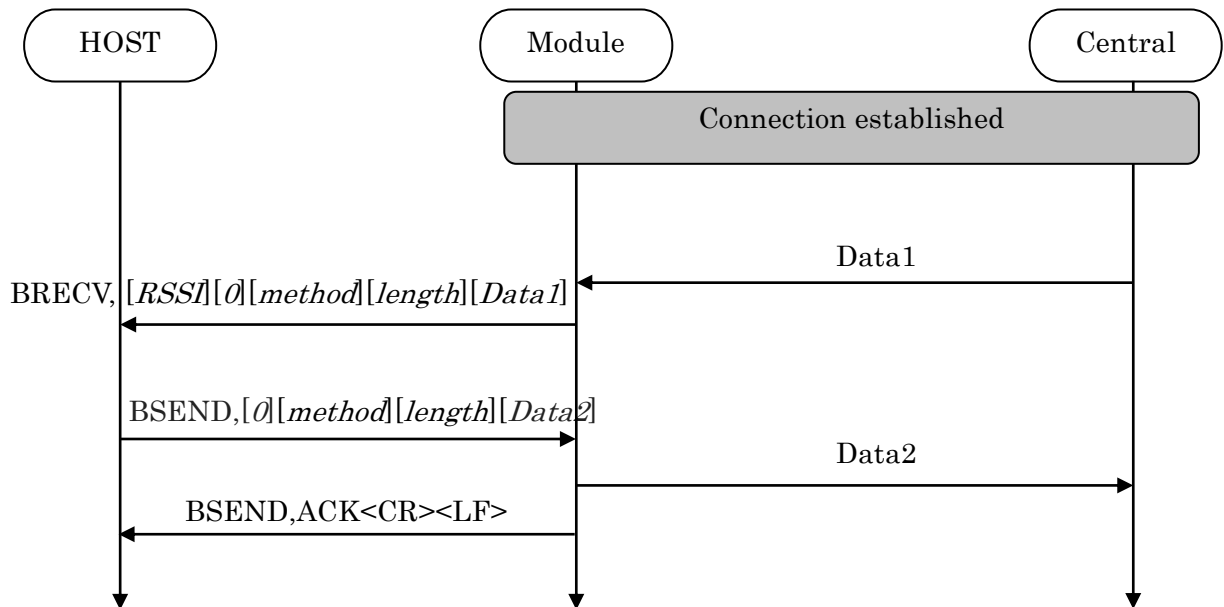

Max send a packet data size = 20bytes
 Max receive a packet data size = 20bytes

4.4.6. Disconnect

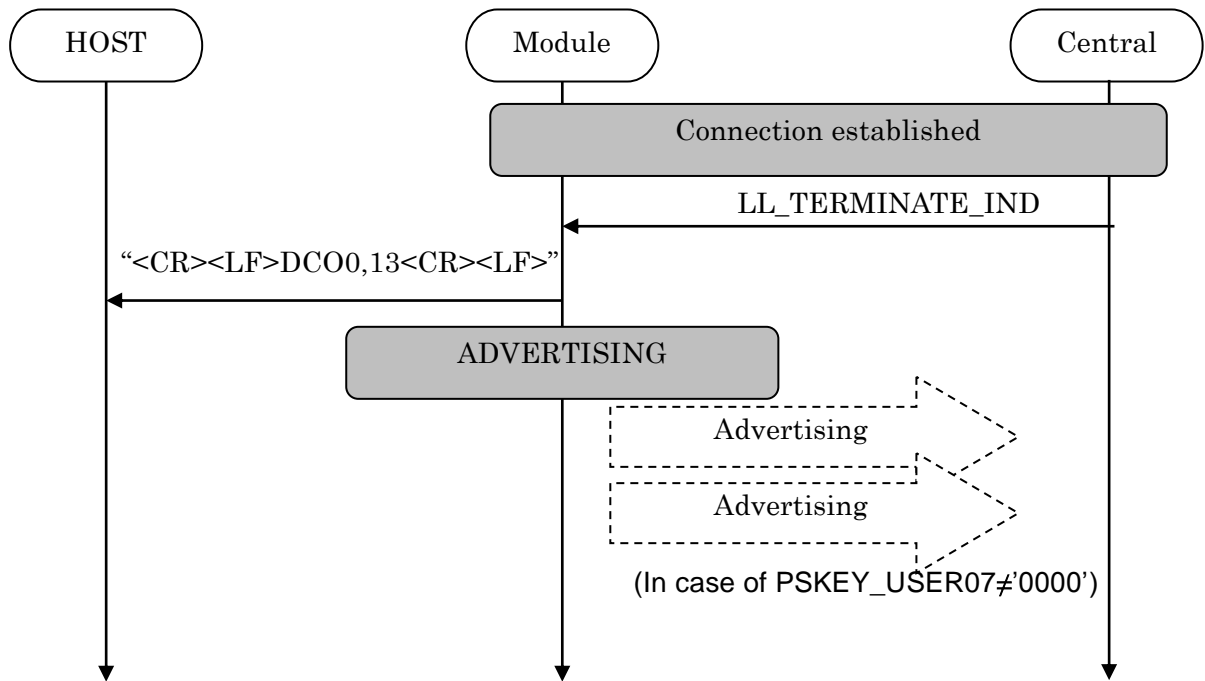

4.4.7. Pairing

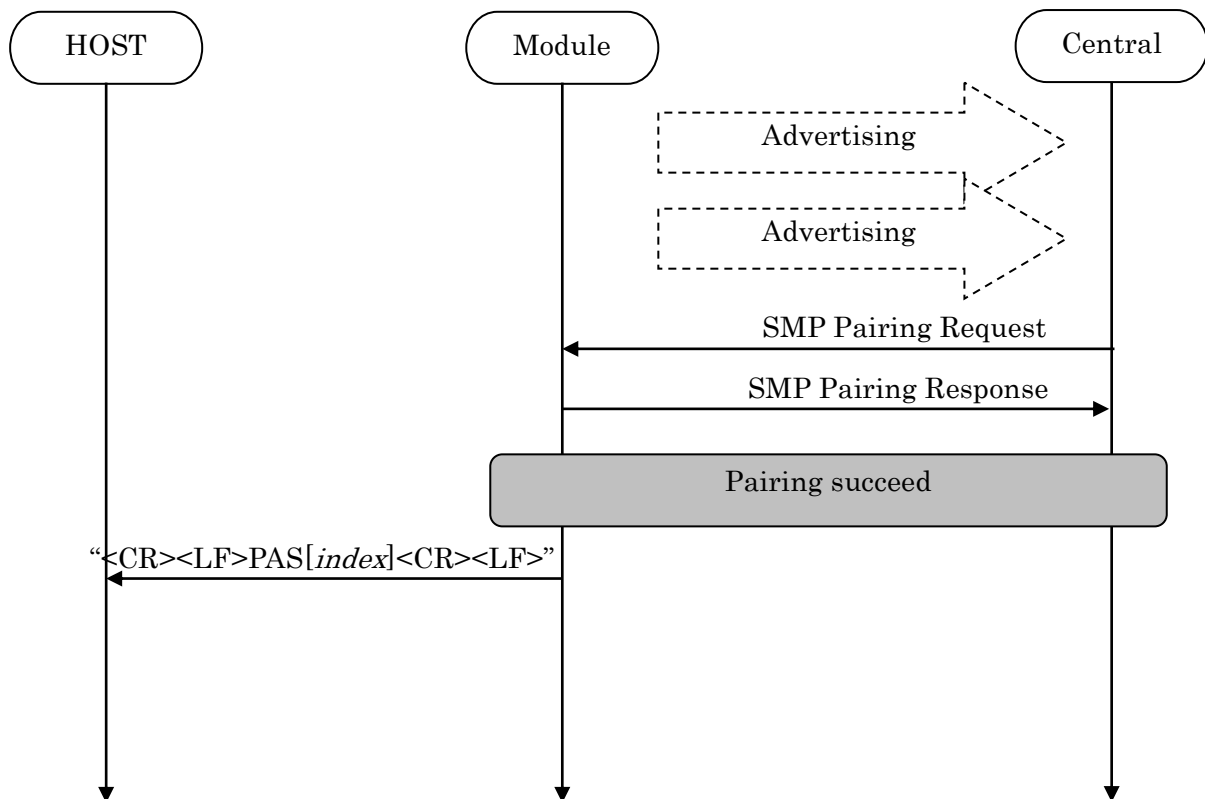

4.4.8. Directed Advertising

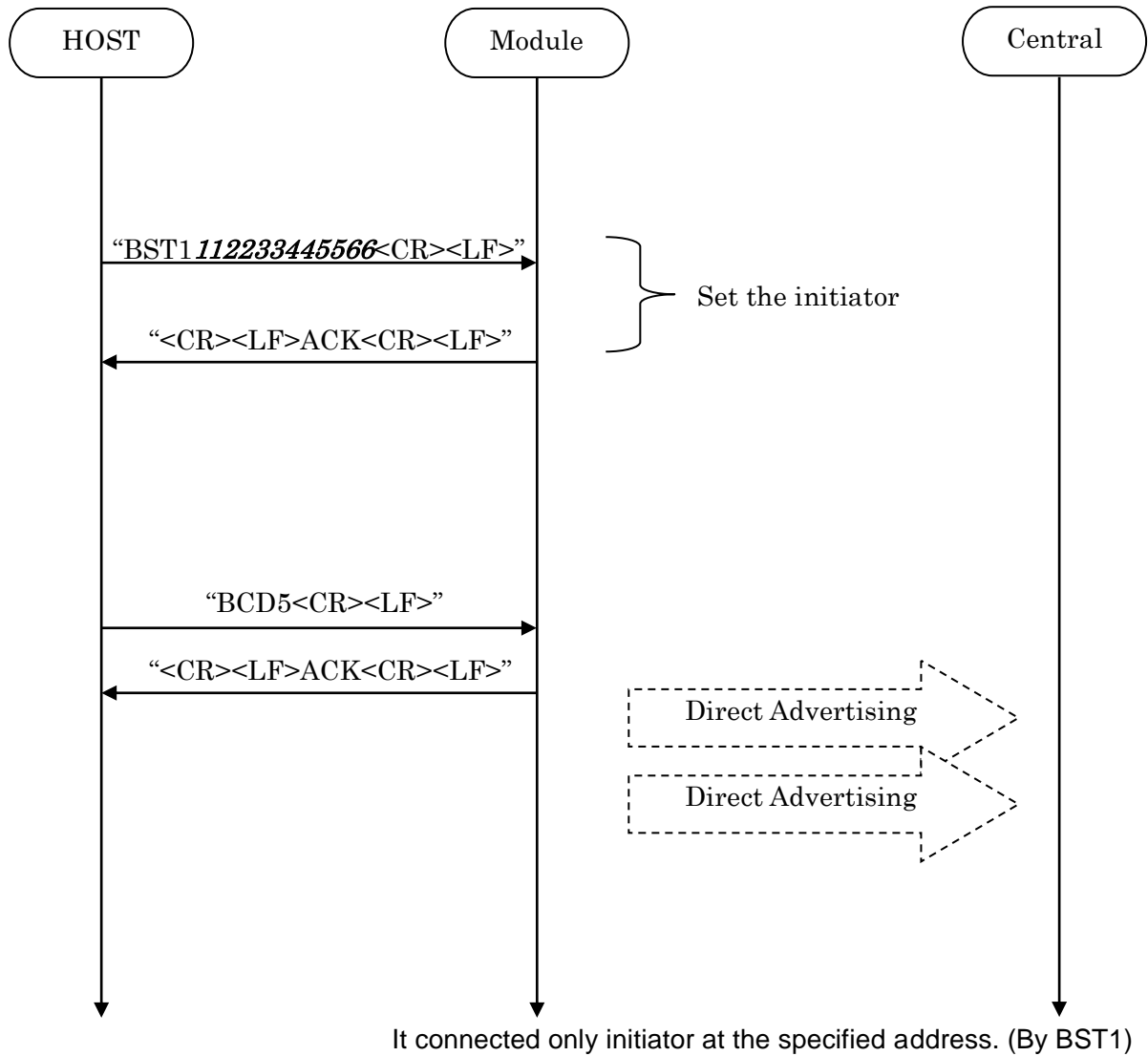

* Direct Advertising Timeout is 1.28sec regardless of Advertising Timeout setting (PSKEY_USER01).

4.4.9. Disconnect Request (GPIO)

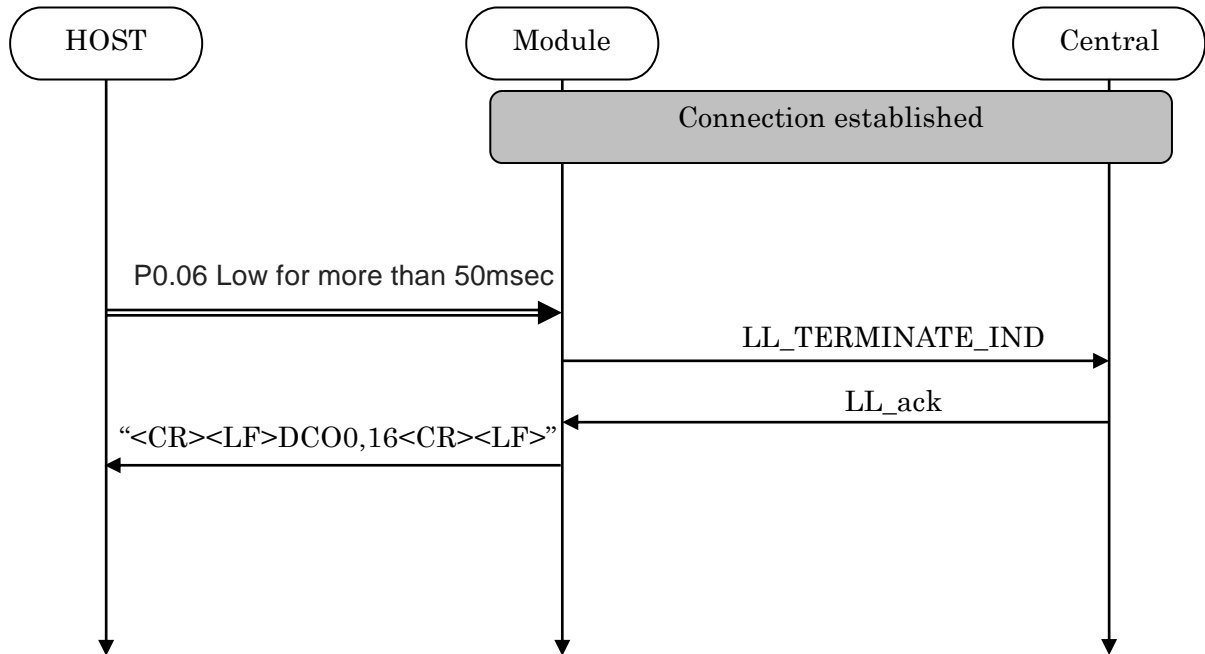

4.4.10. Disconnect Request (Command)

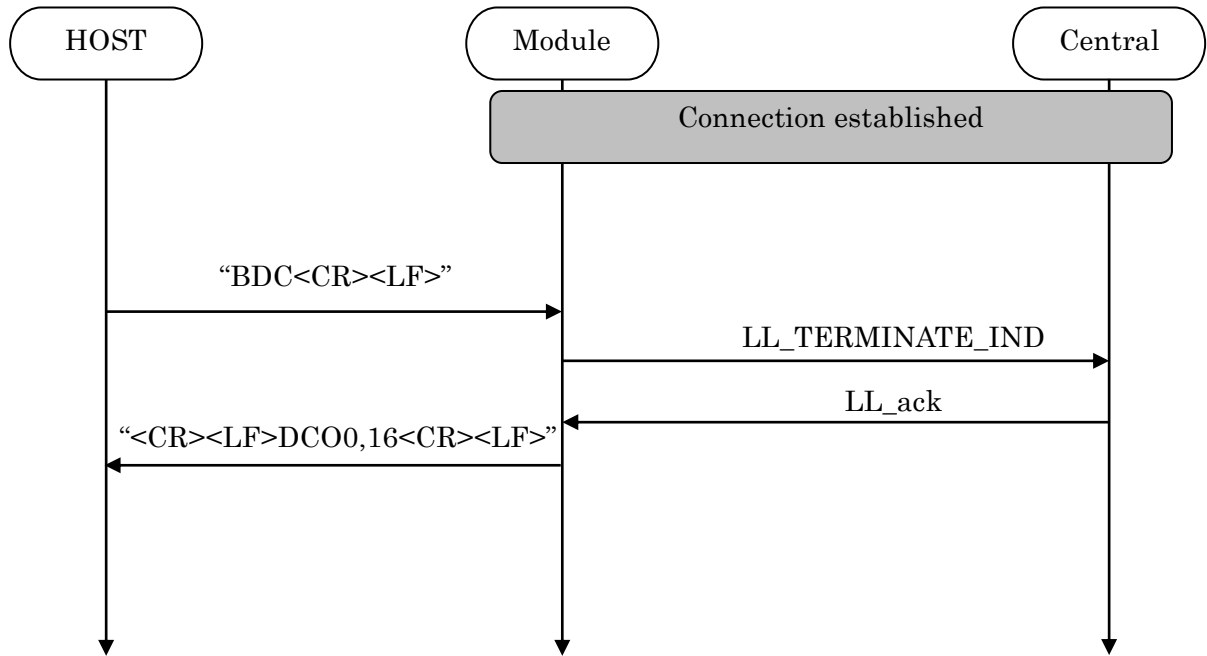

4.5. GPIO state and control

Pin Name	Input / Output	Description
P0.04	Input	Forced initialize(Peripheral's Info)
		Request Sleep mode
		Request Direct Test mode
P0.17	Input	Request DFU mode
		Request Direct Test mode
P0.05	Output	Module active/sleep indicate
P0.19	Output	State indication of module
		DFU indication
P0.06	Input	Disconnect request
		Resume from Power saving mode
		Request Direct Test mode
P0.21	Input	Sleep indication of host
		Resume from Power saving mode
P0.25	Output	Wake up request

EYSGCNAWY-VX

TAIYO YUDEN CO., LTD.

4.5.1. Advertising

P0.19

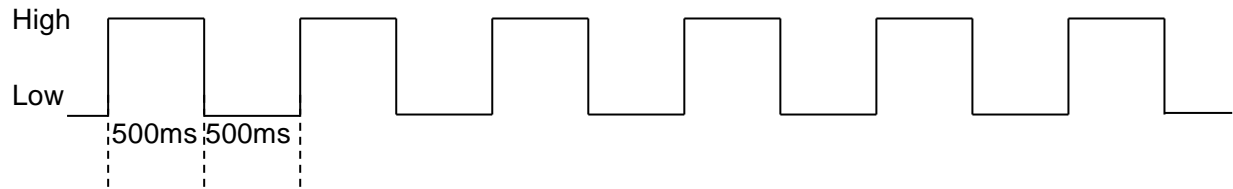

4.5.2. Connect

P0.19 High

4.5.3. Disconnect & Standby

P0.19 Low

4.5.4. Forced initialize

Both Central and Peripheral user setting of the module return to a default value when make P0.04 Low at module startup.

After P0.04 Low, H/W reset or power restart is necessary.

The module start as Peripheral role.

EYSGCNAWY-VX

TAIYO YUDEN CO., LTD.

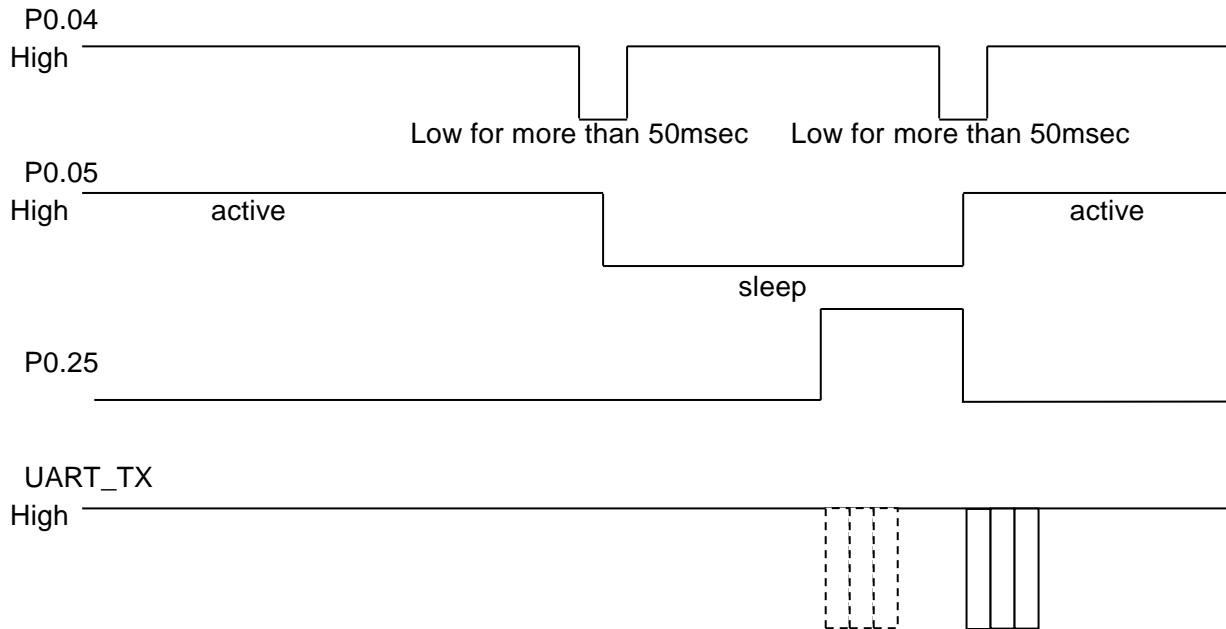
4.5.5. Sleep mode request and indicate

* Buffer size : 128byte If the buffer is full, further data received is discarded without any events.

4.6. Service

Primary Service

TAIYO YUDEN Original Service UUID :

0x442F1570-8A00-9A28-CBE1-E1D4212D53EB

Characteristic

TAIYO YUDEN Original Characteristic UUID :

0x442F1571-8A00-9A28-CBE1-E1D4212D53EB (Read, Notification)

TAIYO YUDEN Original Characteristic UUID :

0x442F1572-8A00-9A28-CBE1-E1D4212D53EB (Write no response)

TAIYO YUDEN Original Characteristic UUID :

0x442F1573-8A00-9A28-CBE1-E1D4212D53EB (Read, Indication)

TAIYO YUDEN Original Characteristic UUID :

0x442F1574-8A00-9A28-CBE1-E1D4212D53EB (Write)

*** GATT Server is implemented in Peripheral role of this software.****4.7. UART configuration**

RX_PIN : P0.03

TX_PIN : P0.01

CTS_PIN : P0.02

RTS_PIN : P0.00

Baud rate : depend on PSKEY_USER00 (default setting: 9600)

Data : 8 bit

Parity : none

Stop : 1 bit

Hardware flow control : Enabled (In case of DTM, flow control is disabled)

4.8. SWD (Serial Wire Debug)

SWDIO :

SWDCLK :

These pins are for FW debug and flash programming I/O.

We recommend your company set up these pins for rewriting the firmware.

4.9. Host wake-up sequence

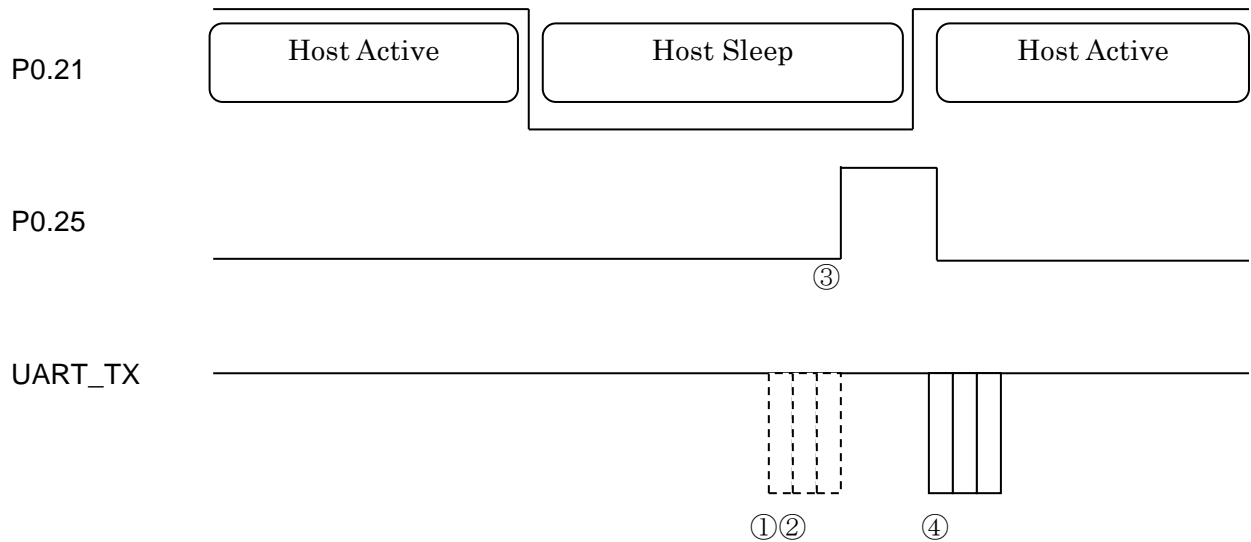

- ① Communication data or an event occurs in HOST Sleep.
- ② It waits until the host becomes active.
- ③ Module request to host wake-up via PIO.
- ④ If HOST becomes Active and Module is active (refer 4.5.5), module send communication data or event.

*** Buffer size : 128byte If the buffer is full, further data received is discarded without any events.**

4.10. DTM (Direct Test Mode)

4.10.1. Enter DTM and exit DTM with GPIO

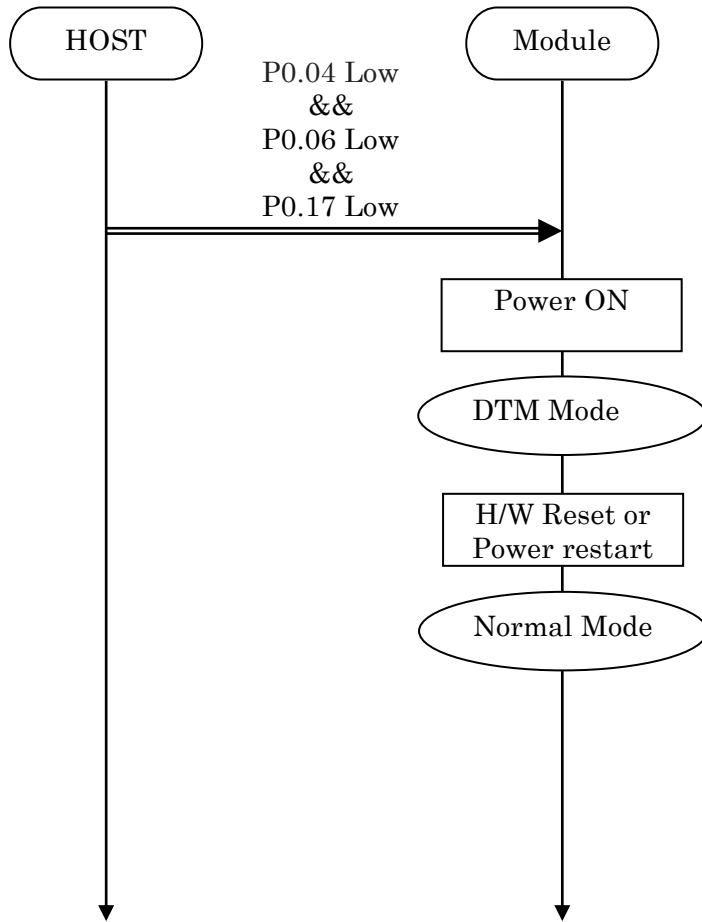

4.10.2. Enter DTM and exit DTM with UART command (permanent)

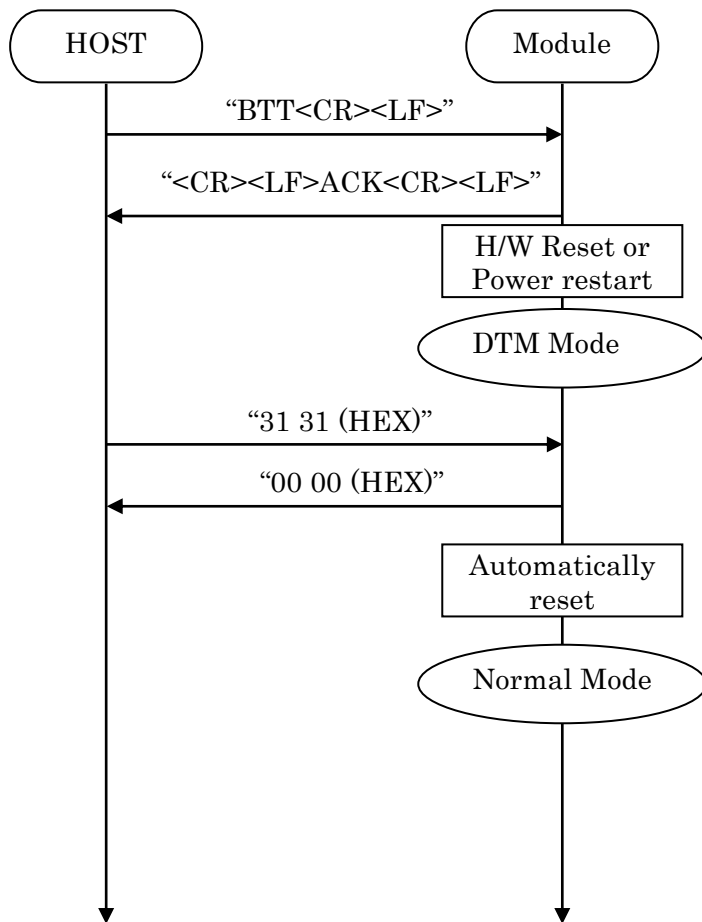

4.10.3. Enter DTM and exit DTM with Command

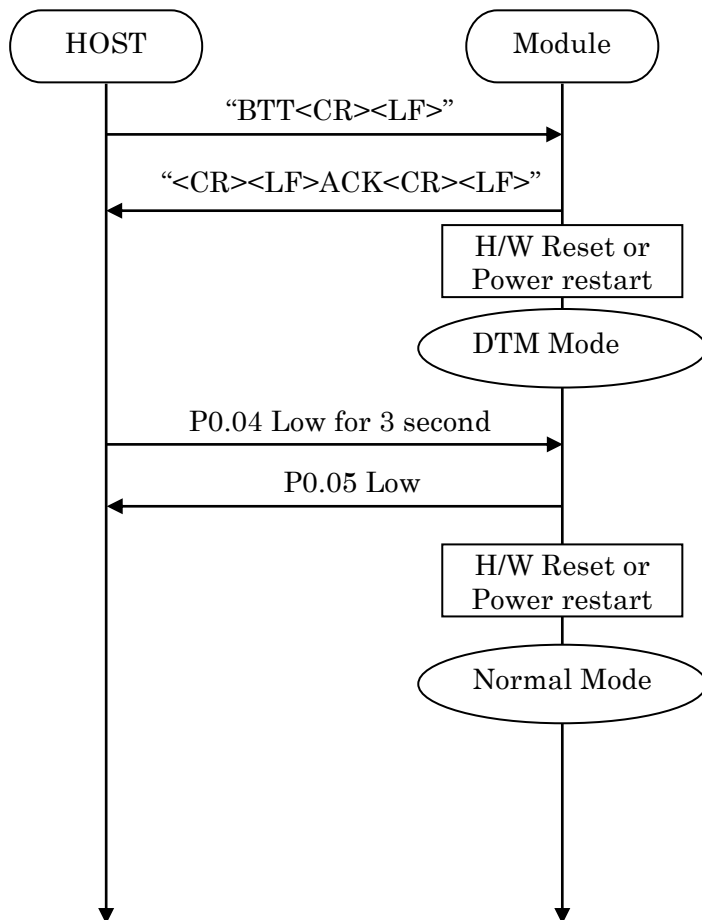

4.10.4. DTM Commands/Events

These commands/events are conforming to DTM of *Bluetooth*[®] specifications V4.0. Please refer to *Bluetooth*[®] specifications V4.0. (Core System Package [Low Energy Controller volume] Part F, Direct Test Mode)

EYSGCNAWY-VX

TAIYO YUDEN CO., LTD.

4.11. GPIO check

Host can inspect GPIO by special commands in DTM.

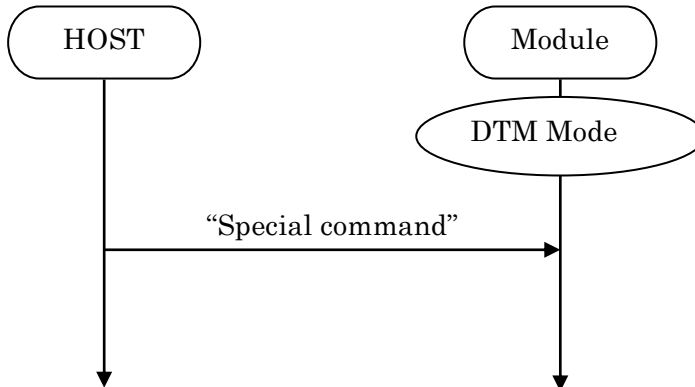

Command (Hex value)	Function	Response
32 30	It makes P0.05 Low.	00 00
32 31	It makes P0.05 High.	00 00
33 30	It makes P0.19 Low.	00 00
33 31	It makes P0.19 High.	00 00
34 30	It makes P0.25 Low.	00 00
34 31	It makes P0.25 High.	00 00
35 30	It makes P0.23 Low.	00 00
35 31	It makes P0.23 High.	00 00
39 39	It acquires state of Input Pin.	XX 00 00 XX: state Bit0: P0.04 (0:Low, 1:High) Bit1: P0.17 (0:Low, 1:High) Bit2: P0.06 (0:Low, 1:High) Bit3: P0.21 (0:Low, 1:High) Example 01 : P0.04 is High. Other Pin is Low. 0F: All Pin is High. 0B: P0.06 is Low. Other Pin is High.

4.12. Sleep Mode (SYSTEM ON)

This Sleep is available in during Advertising and Connection.
 UART I/F is not usable during Sleep.

4.12.1. Enter sleep mode

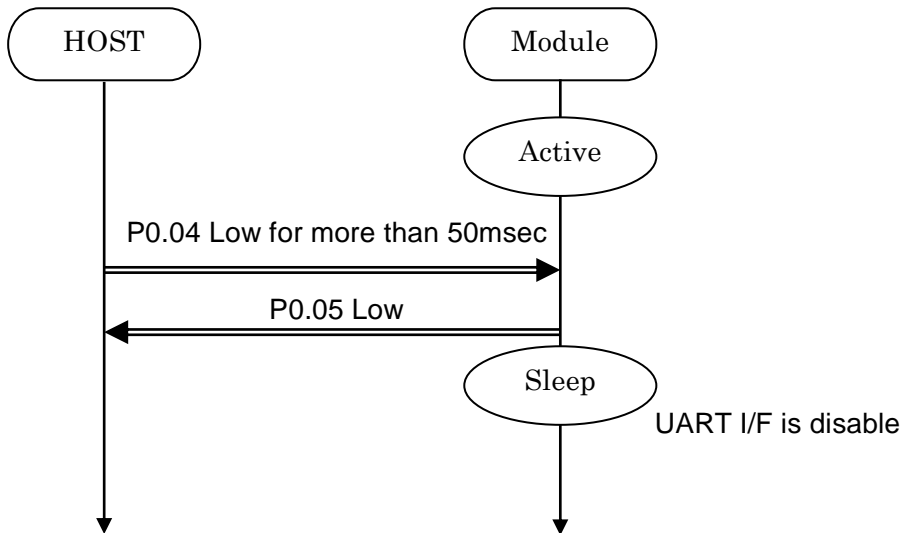

In case of UART data happen, the module notify to Host via P0.25.
 It is same as "Host wake-up".

4.12.2. Exit sleep mode

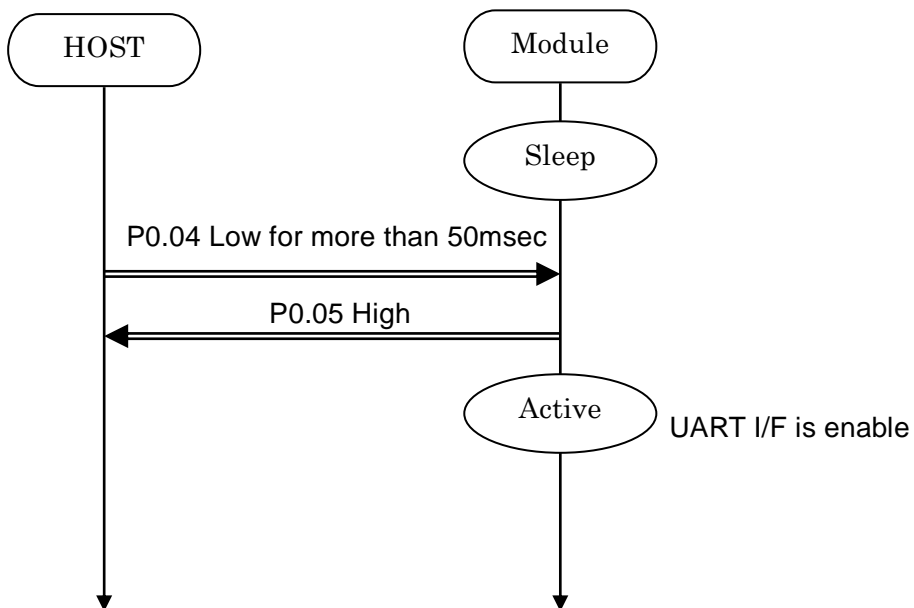

4.13. Power saving mode (SYSTEM OFF)

4.13.1. On startup (In case of PSKEY_USER09='0001')

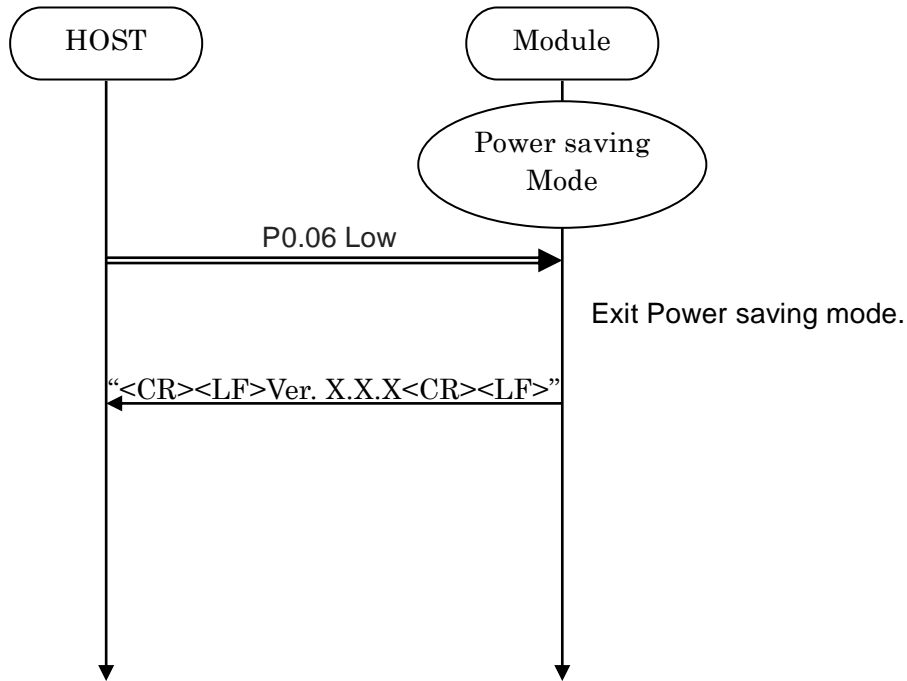

4.13.2. BSP command

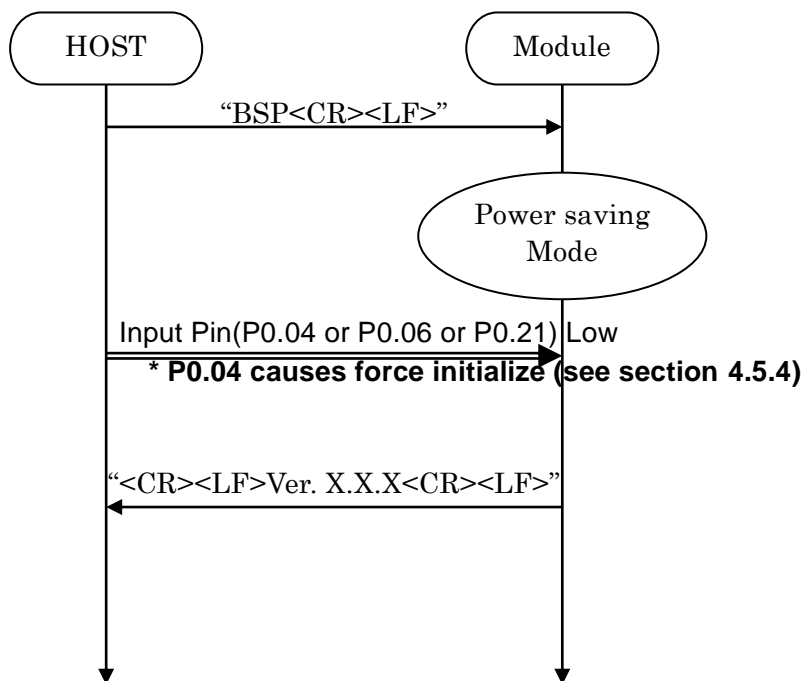

4.14. Device Firmware updates (DFU)

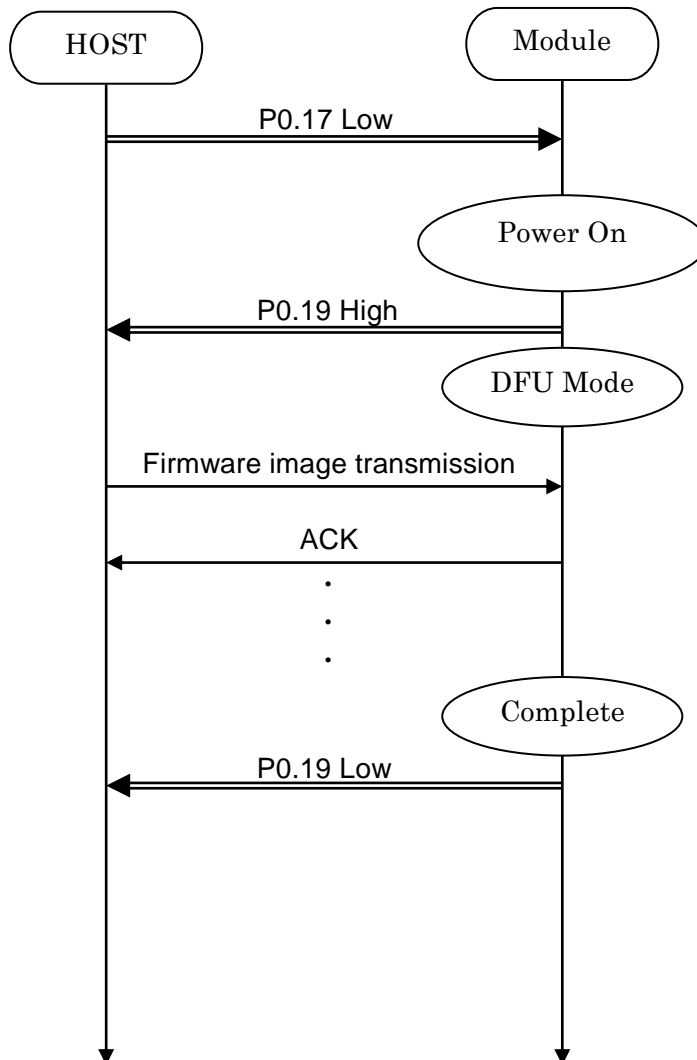

UART

Baud rate : 38400 bps
 Data : 8 bit
 Parity : none
 Stop : 1 bit
 Hardware flow control : Enabled

*** Please contact TAIYO YUDEN when you use this function.**

EYSGCNAWY-VX

TAIYO YUDEN CO., LTD.

4.15. Identify the peer device

Some central devices use a Random Address and make an IRK entry. In this case, the address would change. It is unclear whether the connection with any central. You can add identify to the connection event by the setting PSKEY.

In case of PSKEY_USER08='0001' (Security On) and PSKEY_USER11='0001' (Enable Identify)

4.15.1. Pairing

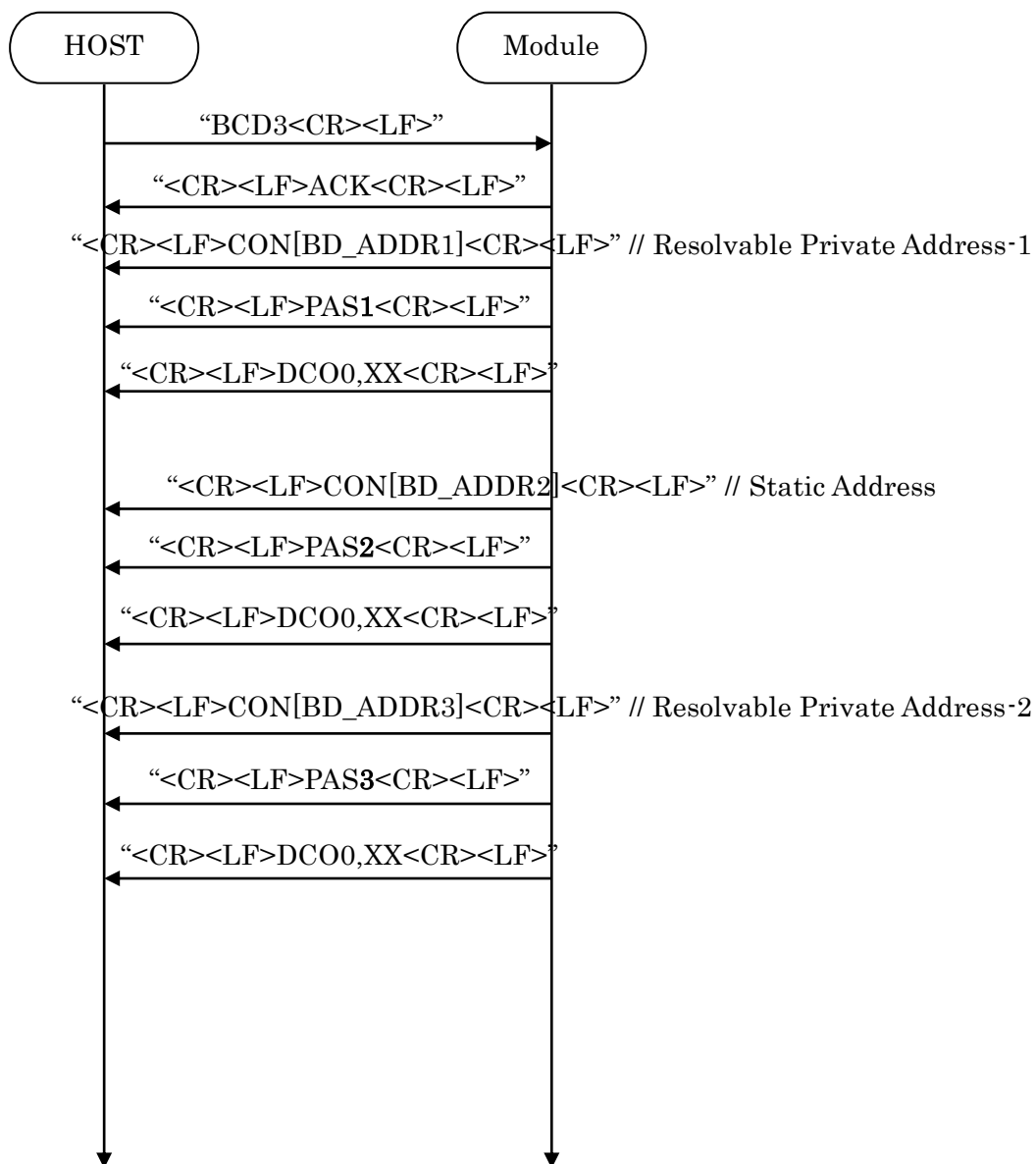

TAIYO YUDEN CO., LTD.

4.15.2. Connection

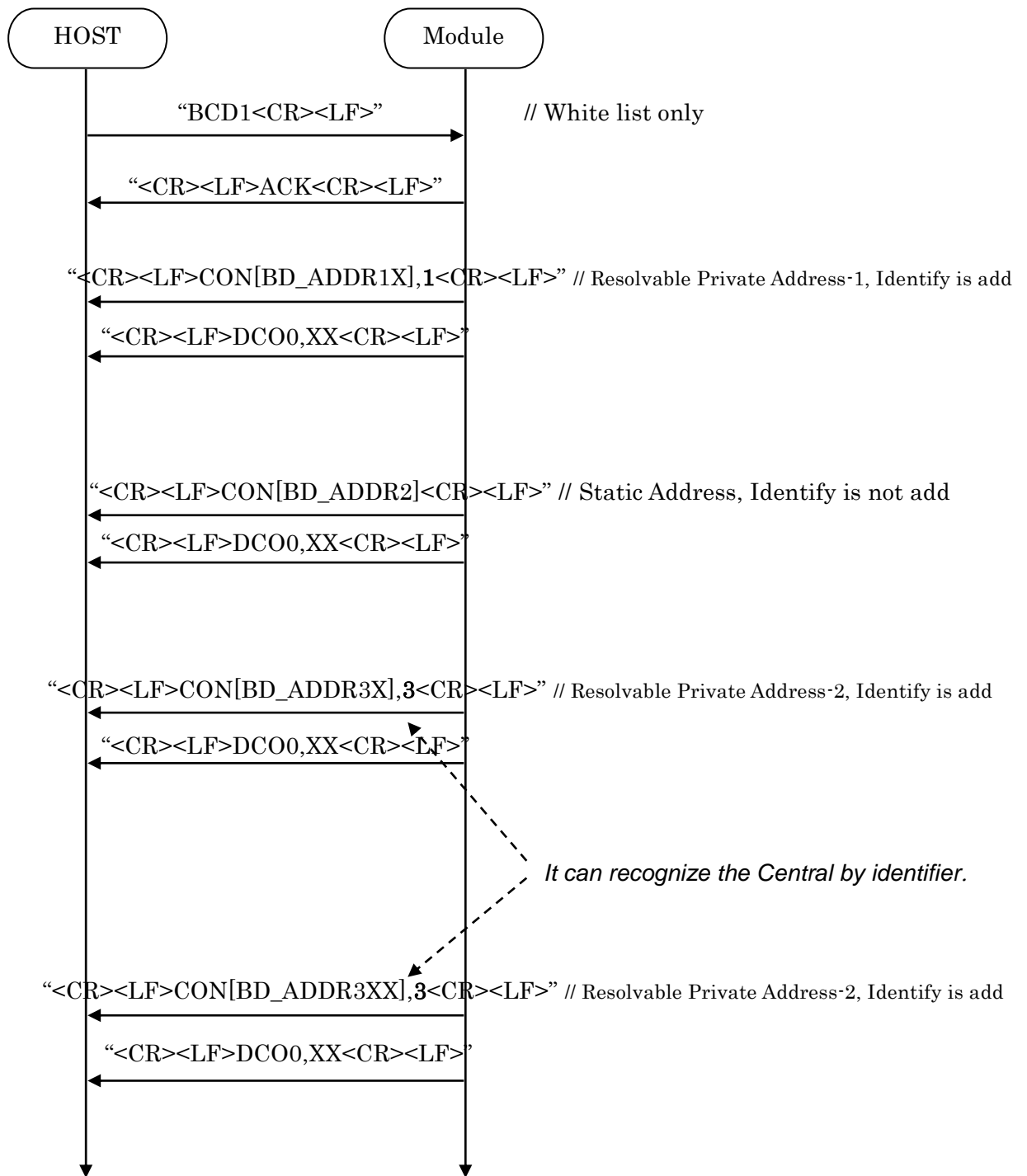

EYSGCNAWY-VX

TAIYO YUDEN CO., LTD.

4.16. Customized Advertising data

Sample iBeacon data

0	1	2	3	4	5	6	7	8
Size (02)	Type (01)	Flag (06)	Size (1A)	Type (FF)	Company ID (4C 00) Little endian		Beacon Type[0] (02)	Beacon Type[1] (15)

9 - 24	25	26	27	28	29
Proximity UUID (442FFFFFF8A009A28CBE1E1D4212D53EB) Big-endian 442FFFFFF-8A00-9A28-CBE1-E1D4212D53EB	Major (01 F4) Big-endian		Minor (03 89) Big-endian		Measured Power (B1)

Please refer "Supplement to the Bluetooth Core Specification" and iBeacon specification about the data format.

The following command stores above data as Customized Advertising data.

```
BST800201061AFF4C000215442FFFFFF8A009A28CBE1E1D4212D53EB01F40389B1<CR><LF>
```

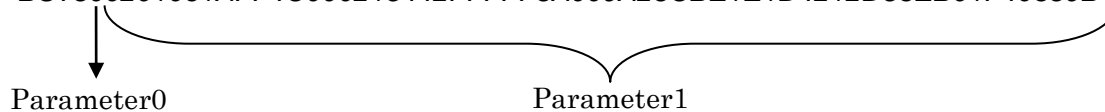

EYSGCNAWY-VX

TAIYO YUDEN CO., LTD.

4.17. LE Secure Connection

4.17.1 Numeric Comparison

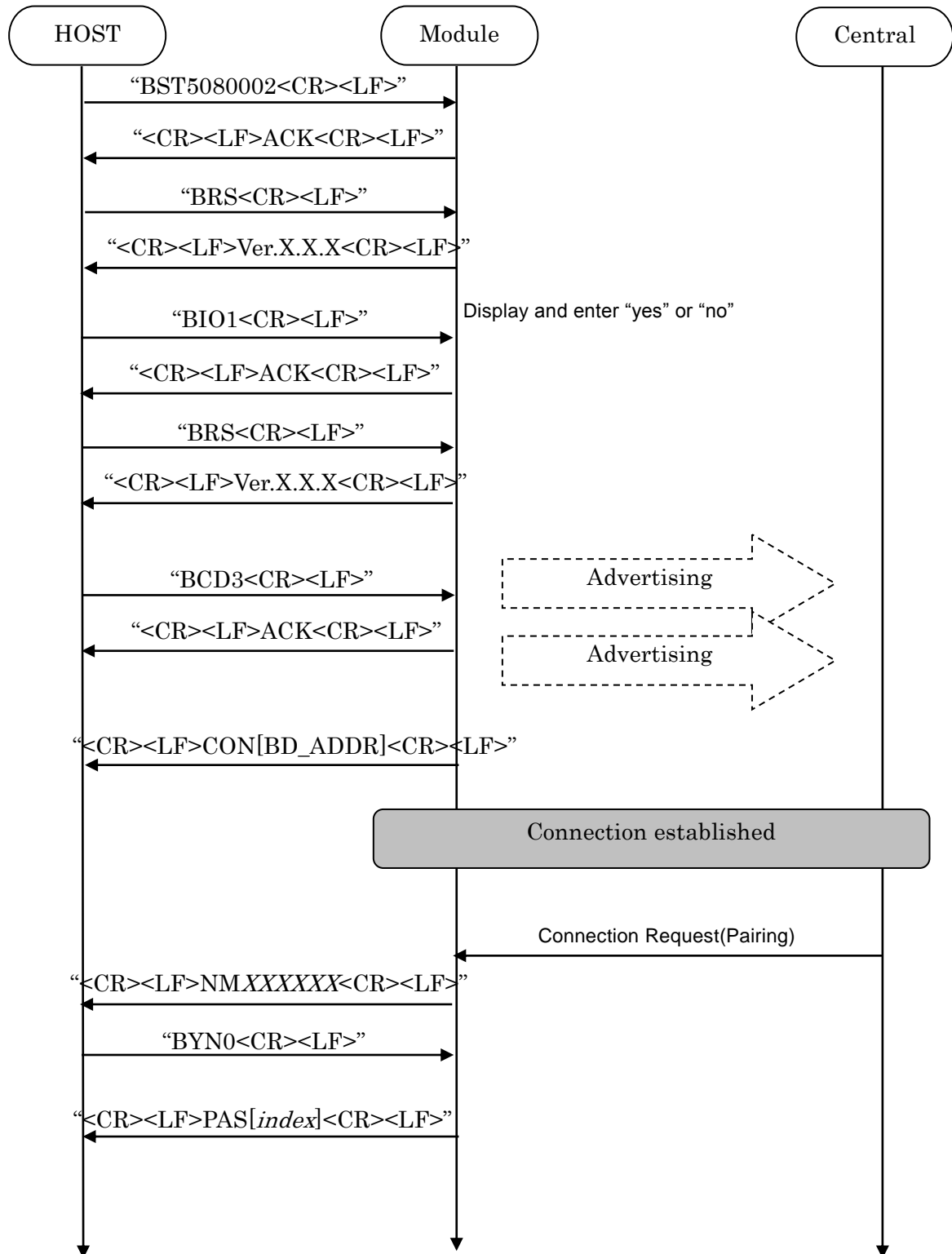

4.17.2 Out of Band

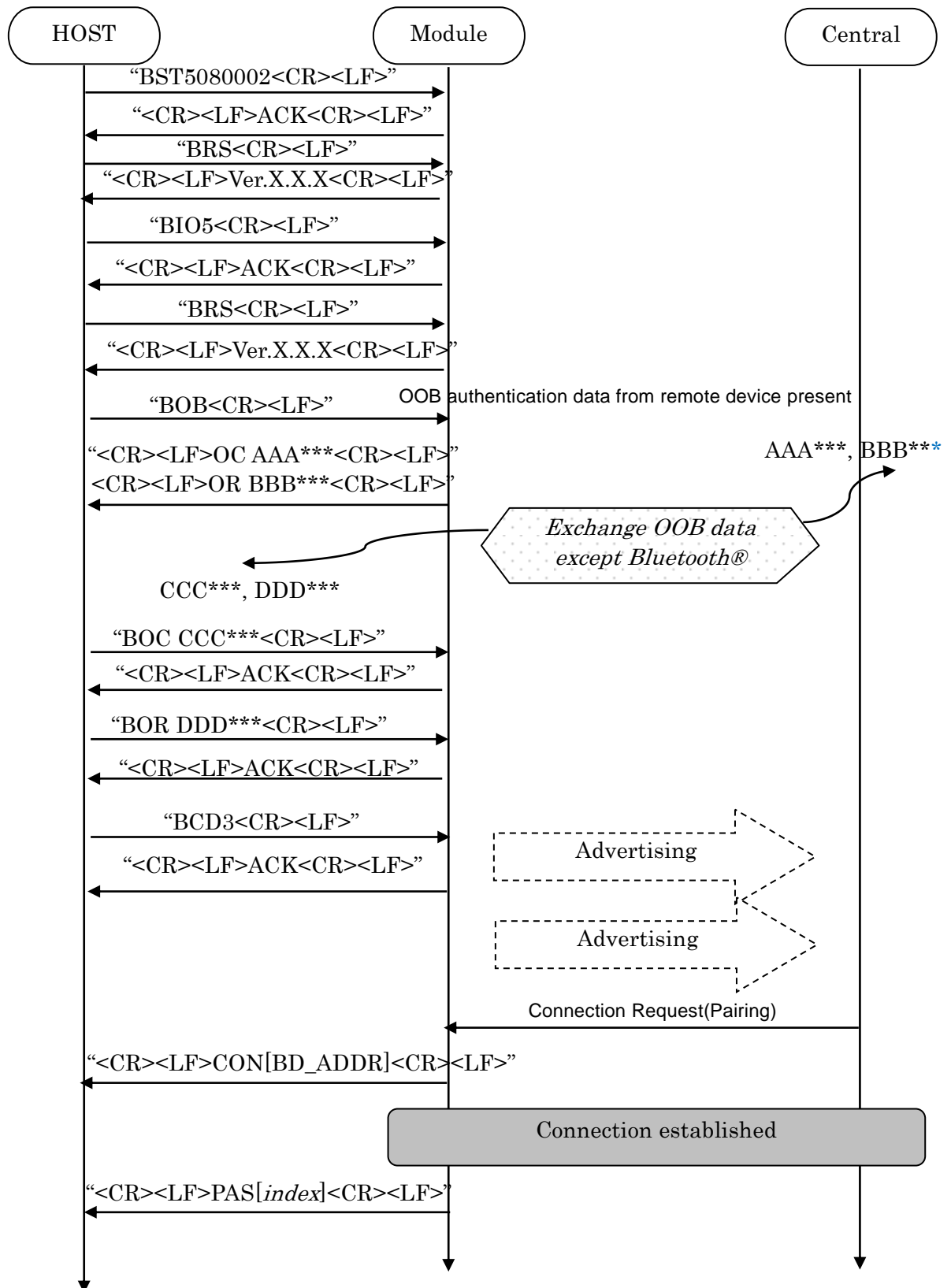

4.17.3 Passkey Entry, Peripheral Displays

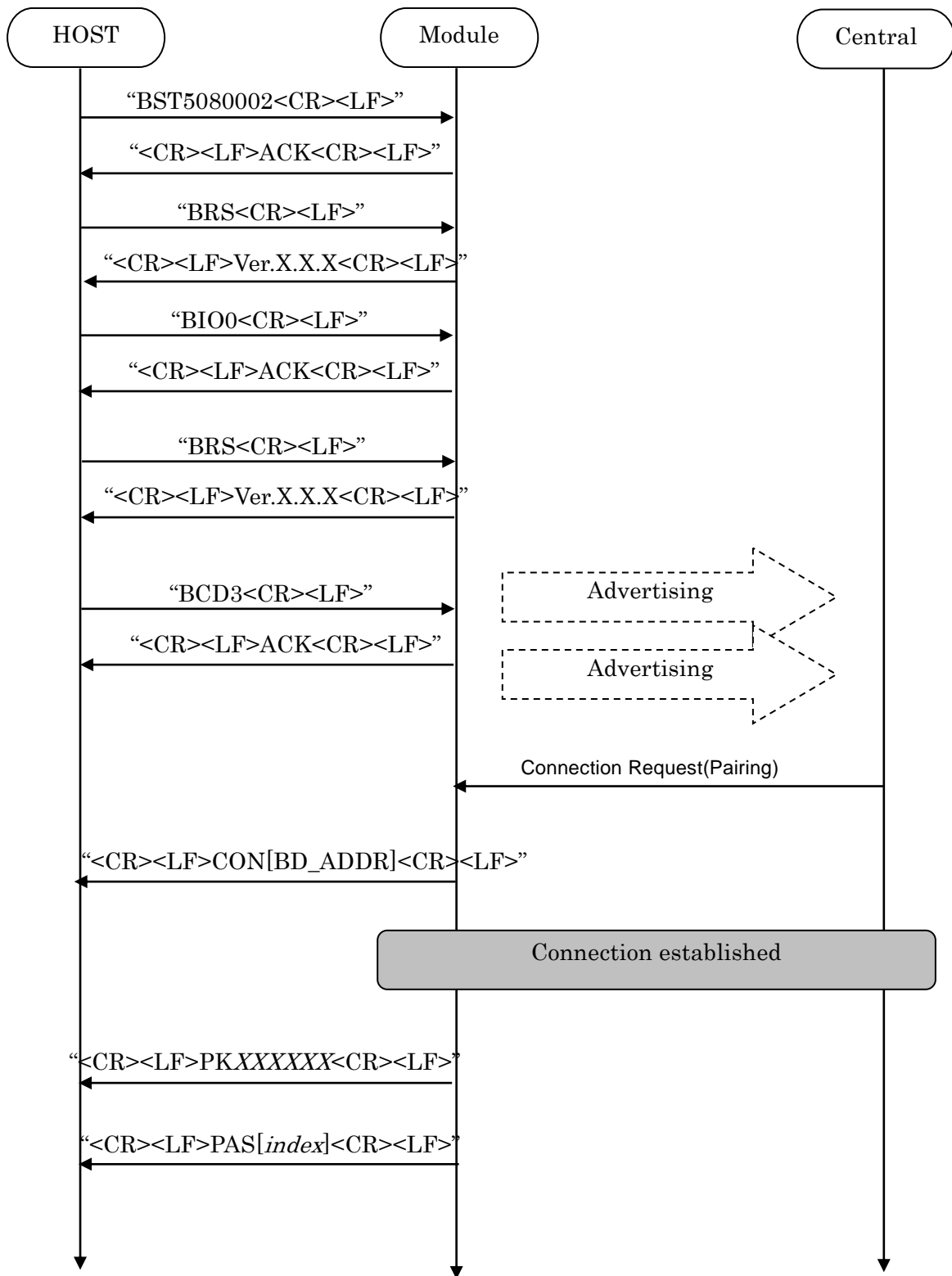

4.17.4 Passkey Entry, User Inputs on Peripheral

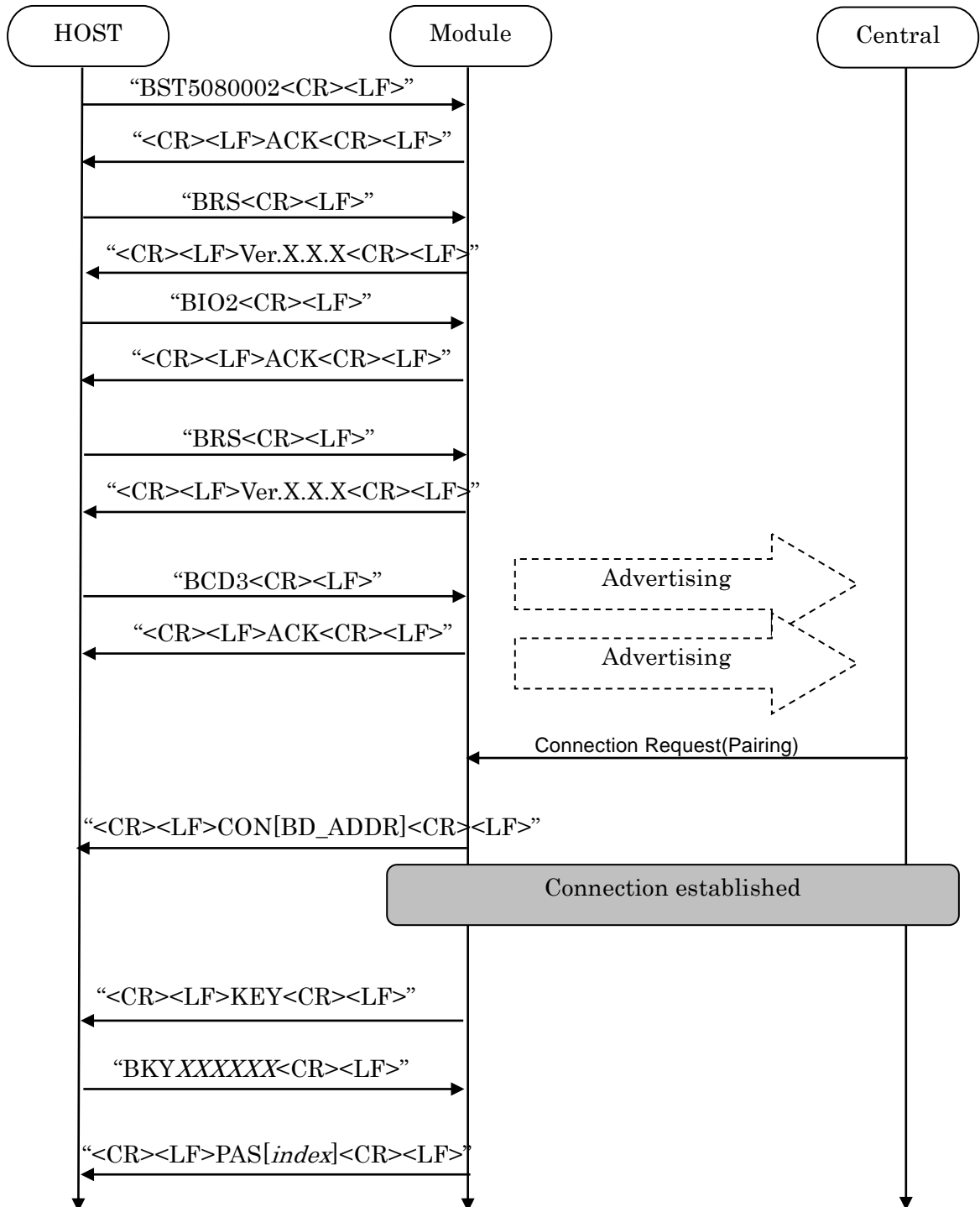

EYSGCNAWY-VX

TAIYO YUDEN CO., LTD.

4.17.5 Just Works

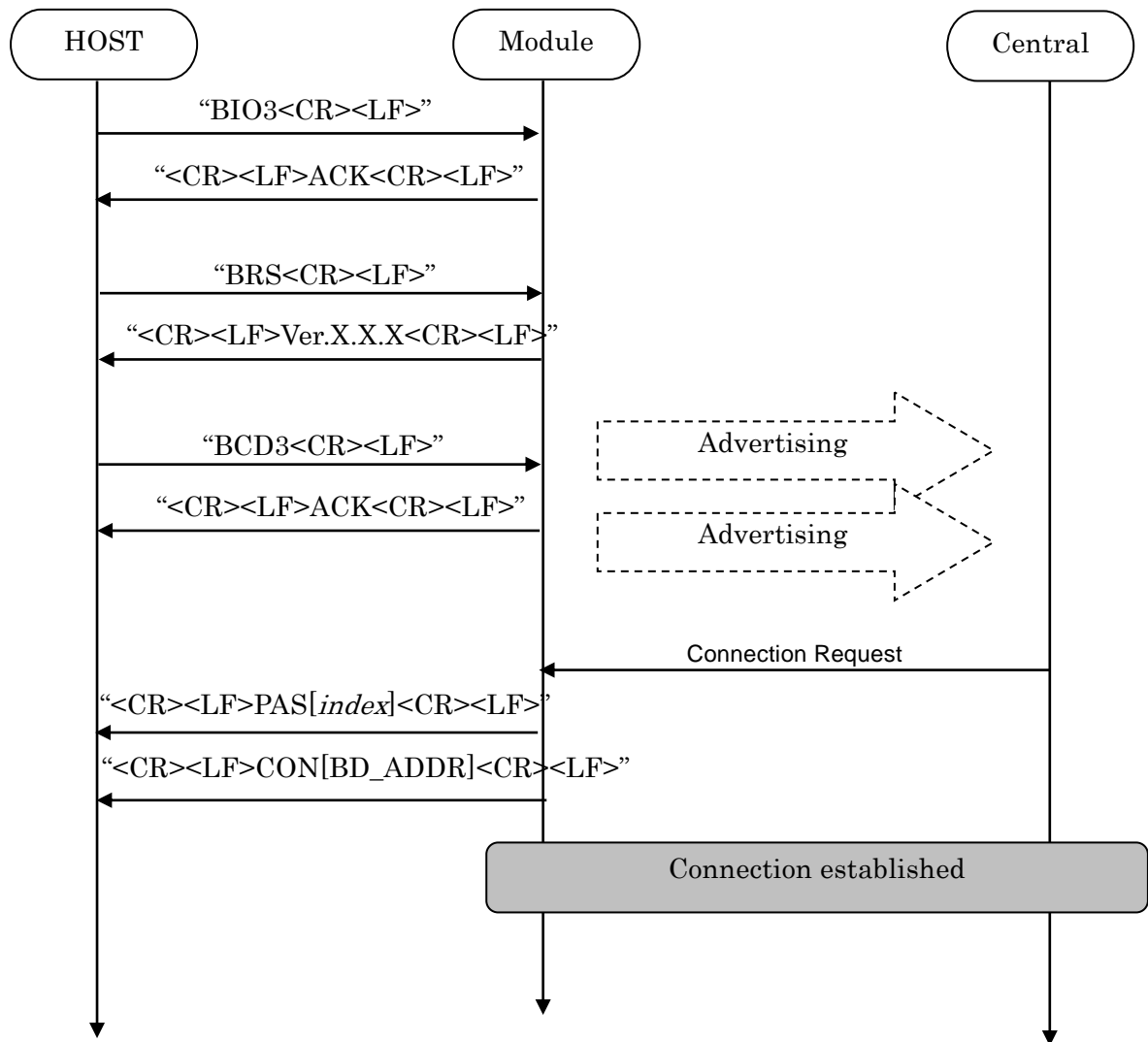

4.18. Notices

1. This application uses Softdevice S130 V2.0.1. for Peripheral.
2. <CR><LF> are not added to the first response for the GT3 command. After outputting the first response, <CR><LF>ACK<CR><LF> is outputted.
3. The parameter of the ST3 command is ignored on and after NULL(0x00).
4. Connection Interval may be refused. It will accept if there is a request for Connection Interval from Central side.
5. ST2 command accepts only Static Address (BLUETOOTH SPECIFICATION Version 4.2 [Vol 6 PartB] 1.3.2.1). A static address is a 48-bit randomly generated address and shall meet the following requirements.
 - The two most significant bits of the static address shall be equal to '1'.
 - All bits of the random part of the static address shall not be equal to '1'.
 - All bits of the random part of the static address shall not be equal to '0'.
6. The buffer size for Sleep (Section 4.5.5) is 128byte. If the buffer is full, further data received is discarded without any events.
7. The buffer size for Host wake-up (Section 4.9) is 128byte. If the buffer is full, further data received is discarded without any events.
8. TT command set the flag for Direct Test Mode.
To reset the flag, input "31 31(HEX)" or set GPIO P0.04 Low for 3 second. Until the flag is reset, the module keeps DTM even after system restart.
9. Do not turn the power off while the data is written to FLASH memory with ST3/ST4/ST5/ST8/DS/DD/TT command. It takes up to 500ms to complete the writing process asynchronously after ACK response.
10. For CD command with parameter 2 (White List Advertising, Customized Advertising data), do not turn on "Discoverable Mode" flag in Flags data type in Customized Advertising data.
11. If the bonding information of the same device is stored multiple times, delete with DS command except the latest stored data.
It may occurs when the bonding information in bonded peer device is deleted then the device is connected in whitelist Advertising mode (CD1 and CD2).
12. Connection parameter update request is sent 5 seconds after the connection is established if the connection parameters of Peripheral are different from the parameters Central has specified in CONNECT_REQ.
13. PSKEY_USER08 and PSKEY_USER 11 must be enabled before setting the Local Device I/O capabilities
14. It takes about 10 seconds to initialize the FLASH area when executing DFU. Please start communication after Pin0.19 goes High after completion of initialization.

EYSGCNAWY-VX

TAIYO YUDEN CO., LTD.

5. Central

5.1 Control Command and Event List

5.1.1. Common Commands

Command Character	Function	Parameter	Response
Configuration These commands are available when scanning stopped.			
ST2	Set Local device address "BST2F01234AABBCC" It will return to the initial value when reset. PSKEY_USER10 shall be set to 0000.	<u>Parameter:</u> BD Address (Static Address)	Successful: ACK Failed: NAK##
ST4	Set default value for User data The setting will be updated after reset. User data is PSKEY, Bonding information and filter's parameter. Please refer section 5.2 about PSKEY. Baudrate setting is not initialized.	/	Successful: ACK Failed: NAK##
ST5	Set PSKEY Value (Note Values 0 >= are valid) Example BST5030100 (set PSKEY 03 to 0x0100) The setting will be updated after reset. Please refer section 5.2.	<u>Parameter 0:</u> PSKEY: DD (Decimal) <u>Parameter 1:</u> Value: HHHH (Hex Word)	Successful: ACK Failed: NAK##
STF	Set Filter's parameter	Please refer section 5.16.	Successful: ACK Failed: NAK##
GT2	Read Local BD Address	/	Successful: Local BD_ADDR, ACK Failed: NAK##
GT5	Read PSKEY Value Example: BGT501 (Get PSKEY 1)	/	Successful: KVHHHH, ACK Failed: NAK##
GT6	Read Paired Peripheral's BD Address and IRK. From top to bottom, index 1 to 7 are assigned for DS command. * All 0xFF is set to IRK. Please refer 5.18 No.4	/	Success: Peripheral's BD Address, IRK, ACK Failed: NAK##

TAIYO YUDEN CO., LTD.

EYSGCNAWY-VX

TAIYO YUDEN CO., LTD.

GTF	Get filter's parameter	Please refer section 5.16.	Successful: Value Failed: NAK##
DS	Delete a Specified Paired Peripheral device.	<u>Parameter:</u> 1-7 : index Please refer GT6 command.	Success: ACK Failed: NAK##
DD	Delete All Paired Peripheral Devices.		Success: ACK Failed: NAK##
TT	Go to Direct Test Mode		Successful: ACK Failed: NAK##
SP	Go to Power saving mode		Failed: NAK##
RS	Reset the module		Successful: Ver. X.X.XC Failed: NAK##
RL	Role switch The setting will be updated after reset.	<u>Parameter:</u> 0 : Peripheral 1 : Central	Successful: ACK Failed: NAK##

EYSGCNAWY-VX

TAIYO YUDEN CO., LTD.

Link Control			
SC	Scan Start or Stop	<u>Parameter</u> '0' – Scanning Stop. '1' – Scanning Start. (Passive scan, Connectable) '2' – Scanning Start. (Active scan, Connectable) '3' – Scanning Start. (Passive scan, Non-Connectable) '4' – Scanning Start. (Active scan Non-Connectable)	Successful: ACK Failed: NAK##
DC	Disconnect		Successful: ACK, DCO Failed: NAK##

EYSGCNAWY-VX

TAIYO YUDEN CO., LTD.

Link Control			
IO	Local Device I/O capabilities 0: Display only. (Passkey Entry) 1: Display and enter "yes" or "no". (Numeric Comparison) 2: Keyboard only. (Passkey Entry) 3: No Input and No Display. (Just Works) 5: Out of Band (OOB) (Default is '3') The setting will be updated after reset.	<u>Parameter</u> I/O capabilities (['0','1','2','3','5'])	Successful: ACK, Failed: NAK##
YN	Answer of numeric collation	<u>Parameter</u> Yes/No '0' – Yes, Accept '1' – No, Reject	Successful: PS,CON Failed:NAK##
KY	Enter the passkey number (Six digit number) Example: BKY895361	Passkey (ASCII) (from "000000" to "999999")	Successful: PS,CON Failed:NAK##
OB	Read Local OOB Data		Successful: OBC 32CHARACTERS OBR 32CHARACTERS Failed: NAK##
OC	Remote OOB Data (Simple Pairing Hash C) 32CHARACTERS	OOB (ASCII) (from "00000000000000000000000000000000" to "FFFFFFFFFFFFFFFFFFFFFFFFFFFFFFFF")	Successful: ACK Failed: NAK##
OR	Remote OOB Data (Simple Pairing Randomizer R) 32CHARACTERS	OOB (ASCII) (from "00000000000000000000000000000000" to "FFFFFFFFFFFFFFFFFFFFFFFFFFFFFFFF")	Successful: ACK Failed: NAK##

EYSGCNAWY-VX

TAIYO YUDEN CO., LTD.

5.1.2. Common Response Events

Response Events	Function	Parameters
ACK	Successful	
NAK##	Failed	Failed Reason – See Error section 5.3. for further details.
CON	Connection successful	Established Remote BD_ADDR
DCO	Disconnect	<u>Parameter 0:</u> 0 : In Peripheral role 1 : In Central role <u>Parameter 1:</u> Reason in hexadecimal See section 5.3.1 for further details.
SCT	Scanning Timeout	
PAS	Pairing Success	<u>Parameter 0:</u> 0 : Paired device is not stored 1-7 : Index of paired device list
INT	Connection Interval	<u>Parameter0:</u> Max Connection Interval <u>Parameter1:</u> Min Connection Interval
ESR	Enable Service	<u>Parameter:</u> 0 : Characteristic 0x1571 (Notification) 1 : Characteristic 0x1573 (Indication)
DSR	Disable Service	<u>Parameter:</u> 0 : Characteristic 0x1571 (Notification) 1 : Characteristic 0x1573 (Indication)
NM	Shown a six digit number (Numeric Value)	<u>Parameter:</u> From "000000" to "999999" (ASCII)
OBC	Local OOB Data (Simple Pairing Hash C)	<u>Parameter:</u> From "00000000000000000000000000000000" to "FFFFFFFFFFFFFFFFFFFFFFFFFFFFFFFF" (ASCII)
OBR	Local OOB Data (Simple Pairing Randomizer R)	<u>Parameter:</u> From "00000000000000000000000000000000" to "FFFFFFFFFFFFFFFFFFFFFFFFFFFFFFFF" (ASCII)
KEY	Request passkey number	
PK	Passkey Number indication	<u>Parameter:</u> From "000000" to "999999" (ASCII)

EYSGCNAWY-VX

TAIYO YUDEN CO., LTD.

5.2 Persistent Store (PS) User Key Description

All Values for "Defaults" are in HEX notation.

Name	PSKEY_USER00	Key Length:	1
Descriptive Name:	Baud rate		
Description:	Set Session Baud Rate. (bps) 0001: 9600, 0002: 19200, 0003: 38400, 0004: 57600, 0005: 115200 0006: 230400, 0007: 460800, 0008: 921600		
Default:	0001 (9600bps)		
Range	0001 - 0008		

Name	PSKEY_USER01	Key Length:	1
Descriptive Name:	Scanning Timeout (sec)		
Description:	Scanning Timeout defines the timeout for the scanning. 0000 means timeout is disabling. Scanning will continue forever.		
Default:	003C (60sec)		
Range	0000 – 3FFF (0 – 16383sec)		

Name	PSKEY_USER02	Key Length:	1
Descriptive Name:	Scanning Interval (msec)		
Description:	The time between the start of two consecutive scanning events. The value in this parameter is multiplied by 0.625msec.		
Default:	00A0 (100msec)		
Range	0004 – 4000 (2.5msec – 10.24sec)		

Name	PSKEY_USER03	Key Length:	1
Descriptive Name:	Connection Interval Minimum (msec)		
Description:	Defines minimum value for the connection interval. The value in this parameter is multiplied by 1.25msec.		
Default:	0014 (25msec)		
Range	0006 – 0C80 (7.5 – 4000msec)		

EYSGCNAWY-VX

TAIYO YUDEN CO., LTD.

Name	PSKEY_USER04	Key Length:	1
Descriptive Name:	Connection Interval Maximum (msec)		
Description:	Defines maximum value for the connection interval. The value in this parameter is multiplied by 1.25msec.		
Default:	0028 (50msec)		
Range	0006 – 0C80 (7.5 – 4000msec)		

Name	PSKEY_USER05	Key Length:	1
Descriptive Name:	Slave latency		
Description:	Defines the slave latency for the connection in number of connection events. The Slave Latency field shall have a value in the range of 0 to ((SupervisionTimeout / connectionIntervalMax*2) -1). The Slave Latency field shall be less than 500.		
Default:	0000		
Range	0000 – 01F3 (0 – 499)		

Name	PSKEY_USER06	Key Length:	1
Descriptive Name:	Supervision Timeout (msec)		
Description:	Defines the connection supervision timeout. The value in this parameter is multiplied by 10msec.		
Default:	01F4 (5000msec)		
Range	000A– 0C80 (100 – 32000msec)		

Name	PSKEY_USER07	Key Length:	1
Descriptive Name:	Auto Scanning Start setting		
Description:	This will store Auto Scanning Start setting. The parameter is correspond to that of SC command. “0000” : Auto start OFF “0001” : Auto start, Passive scan, Connectable “0002” : Auto start, Active scan, Connectable “0003” : Auto start, Passive scan, Non-Connectable “0004” : Auto start, Active scan, Non-Connectable		
Default:	0000		
Range	0000– 0004		

TAIYO YUDEN CO., LTD.

EYSGCNAWY-VX

TAIYO YUDEN CO., LTD.

Name	PSKEY_USER08	Key Length:	1
Descriptive Name:	Scan window setting		
Description:	This will store Scan window setting. The value in this parameter is multiplied by 0.625msec. Scan window shall be less than or equal to Scan interval.		
Default:	0032 (31.25msec)		
Range	0004 – 4000 (2.5msec – 10.24sec)		

Name	PSKEY_USER09	Key Length:	1
Descriptive Name:	Power saving mode setting at startup.		
Description:	This will store Power saving mode setting at startup. "0000" will disable Power saving mode. It does not enter Power saving mode. "0001" will enable Power saving mode. It enters Power saving mode. Regardless of the setting, module can enter the mode by BSP command.		
Default:	0000		
Range	0000– 0001		

Name	PSKEY_USER10	Key Length:	1
Descriptive Name:	BD Address type		
Description:	Set the type of BD Address "0000": Static Address "0001" – "000F" : Resolvable Private Address The value in this parameter is multiplied by 60sec and used as address update interval. (1minute – 15minutes)		
Default:	0000		
Range	0000– 000F		

Name	PSKEY_USER11	Key Length:	1
Descriptive Name:	Notice of Connection Parameter Update.		
Description:	"0000": It does not notice the Connection Interval. "0001": When Connection Interval is changed, It notify via "INT" event.		
Default:	0000		
Range	0000– 0001		

TAIYO YUDEN CO., LTD.

EYSGCNAWY-VX

TAIYO YUDEN CO., LTD.

Name	PSKEY_USER12	Key Length:	1
Descriptive Name:	TX power setting.		
Description:	Set the radio's transmit power. Radio transmit power in dBm (accepted values are -30, -20, -16, -12, -8, -4, 0, and 4 dBm). 0000: 4, 0001: 0, 0002: -4, 0003: -8, 0004: -12, 0005: -16, 0006: -20, 0007: -30		
Default:	0000		
Range	0000– 0007		

Name	PSKEY_USER13	Key Length:	1
Descriptive Name:	DC/DC converter setting		
Description:	DC/DC converter setting. "0000" will disable internal DC/DC converter (and use internal LDO). "0001" will enable internal DC/DC converter. Note: When supply voltage goes below 2.1V, DCDC is disabled, and enabled when the supply voltage goes up again. About hardware specification, please refer to "DataReport".		
Default:	0000		
Range	0000– 0001		

Name	PSKEY_USER14	Key Length:	1
Descriptive Name:	RSSI and Advertising data notification setting		
Description:	RSSI and Advertising data notification setting. Please refer section 5.15 for details. "0000" : RSSI disable and Data disable "0001" : RSSI enable and Data disable "0002" : RSSI enable and Data enable		
Default:	0000		
Range	0000– 0002		

EYSGCNAWY-VX

TAIYO YUDEN CO., LTD.

Name	PSKEY_USER15	Key Length:	1
Descriptive Name:	Filter (Device name)		
Description:	Set the filter of Device name. "0000" will disable the filter. "0001" will enable the filter. Device name is set with STF command.		
Default:	0001		
Range	0000– 0001		

Name	PSKEY_USER16	Key Length:	1
Descriptive Name:	Filter (Advertising data)		
Description:	Set the filter of Advertising data. "0000" : disable filter "0010" : iBeacon (UUID filter OFF) "0011" : iBeacon (UUID filter ON) "0020" : iBeacon (-ish) (UUID filter OFF) "0021" : iBeacon (-ish) (UUID filter ON) UUID is set with STF command.		
Default:	0000		
Range	0000– 0021		

Name	PSKEY_USER17	Key Length:	1
Descriptive Name:	Filter (RSSI)		
Description:	Set the filter of RSSI. Parameter "00XX" XX : -128 - 127 (0x80 – 0x7F : two's complement)		
Default:	0080		
Range	0080– 007F		

EYSGCNAWY-VX

TAIYO YUDEN CO., LTD.

Name	PSKEY_USER18	Key Length:	1
Descriptive Name:	Filter (BD Address)		
Description:	<p>Set the filter of BD Address. The filter checks "Allow" then "Deny".</p> <p>Parameter "00XY"</p> <p>X : Allow Y : Deny</p> <p>0 Disable filter</p> <p>1 Specify in BD Address</p> <p>2 Specify in Company ID(Public BD Address)</p> <p>BD Address is set with STF command.</p>		
Default:	0000		
Range	0000– 0022		

5.3 Error Codes

#	Error Name	Program Logic Cause / Action taken by Host
-1	Unknown Error	There is the possibility that the hardware is out of order.
00	Command Not Recognized	It confirms whether or not the command is correct.
01	Bad Parameter	It confirms parameter range.
02	Invalid State	Stop Advertising / Scanning or Disconnect.
04	UART Buffer full (buffer size : 128byte)	The commands shall be sent after previous command response.
05	Connection Fail (Central Only)	Please try again. If bond information exists, delete it and try again.
06	Device Full	Flash block for storing pairing information is full. (Max 7) To store new device information, delete with BDD command.
07	Pairing Failed	Please try again. If bond information exists, delete it and try again.
08	FLASH access error	Please run forced initialize (5.5.4).
11	Connection Parameter Error	It confirms connection parameter. Check PSKEY settings.
21	Advertising Parameter Error (Peripheral Only)	It confirms advertising data and parameter. Check PSKEY setting. If Advertising data is customized, check the parameter and the response of ST9 command.
22	Whitelist Error	It confirms whether or not bonded devices exist.
31	Scanning Parameter Error (Central Only)	It confirms scanning parameter. Check PSKEY setting.

5.3.1. Disconnect reason

#	Error Name	Description
08	BLE_HCI_CONNECTION_TIMEOUT	Connection Timeout.
13	BLE_HCI_REMOTE_USER_TERMINATED_CONNECTION	Remote User Terminated Connection.
16	BLE_HCI_LOCAL_HOST_TERMINATED_CONNECTION	Local Host Terminated Connection.
3D	BLE_HCI_CONN_TERMINATED_DUE_TO_MIC_FAILURE	Connection Terminated due to MIC Failure.

About other error codes, please see below.

https://infocenter.nordicsemi.com/topic/com.nordic.infocenter.s130.api.v2.0.1/group_ble_hci_status_codes.html

5.4 Message Sequence Chart

5.4.1. Power On (In case of PSKEY_USER01#'0000' and PSKEY_USER07#'0000')

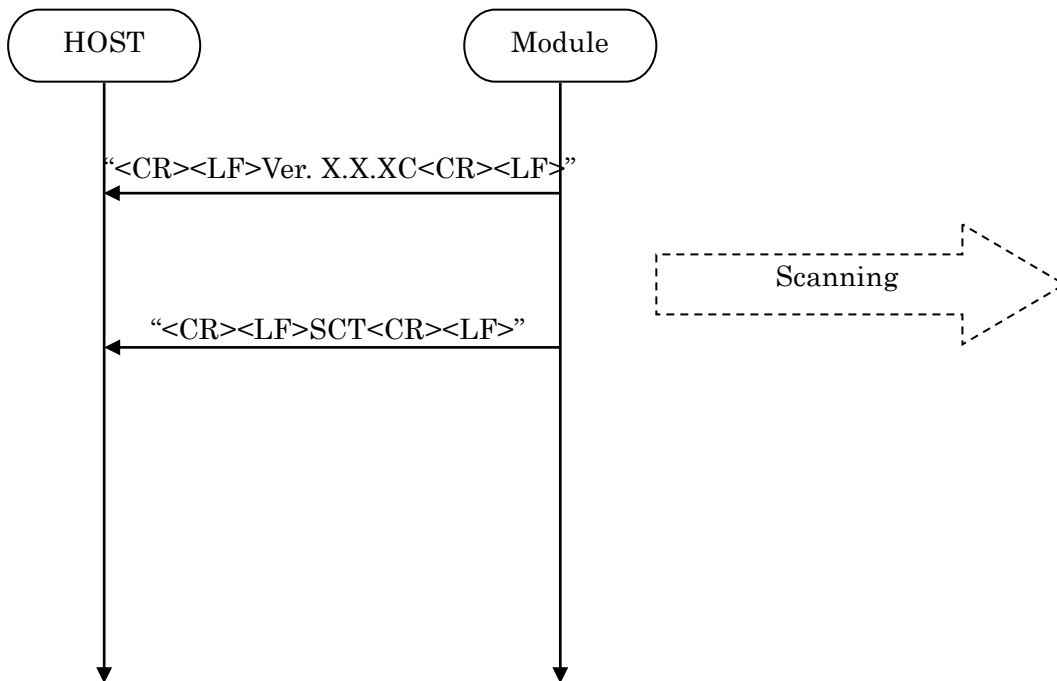

5.4.2. Scan Start

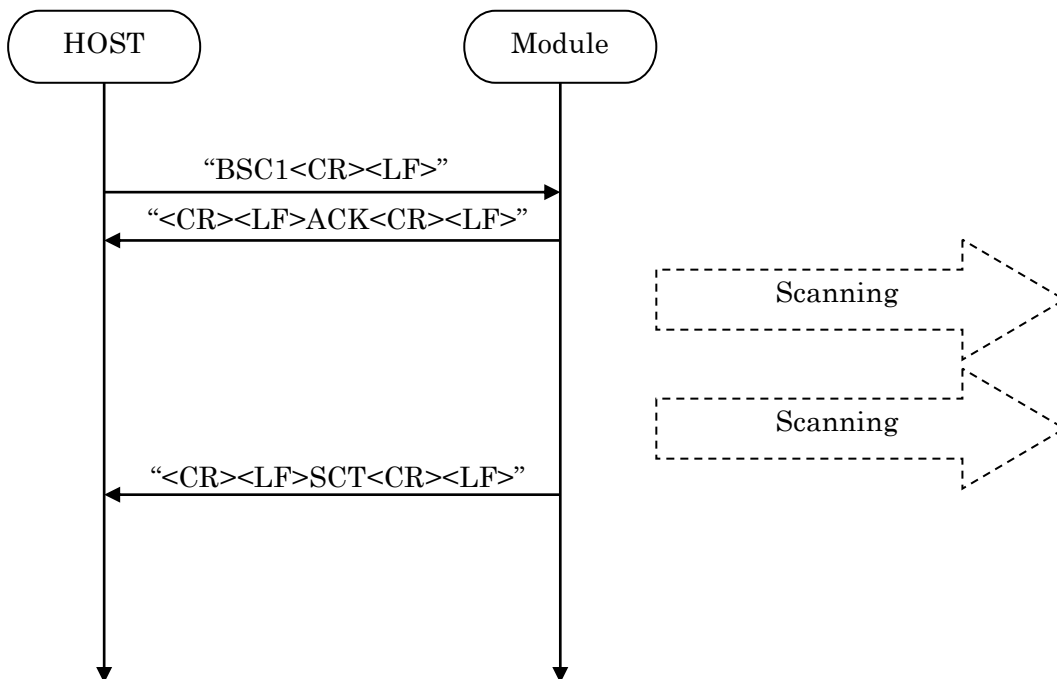

5.4.3. Scanning Stop

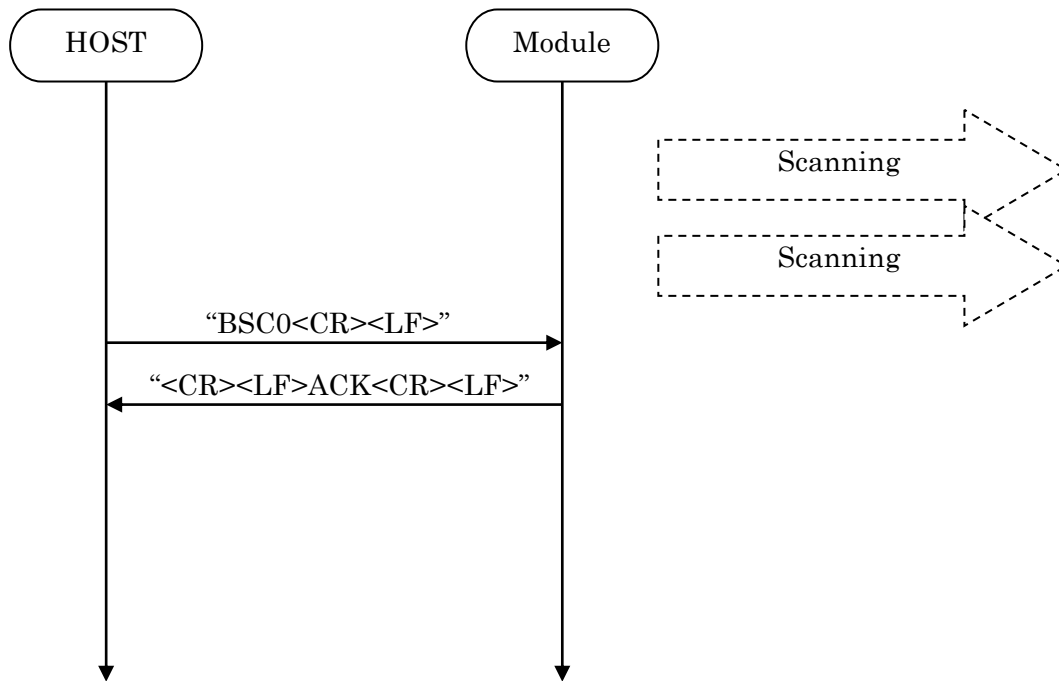

5.4.4. Connect

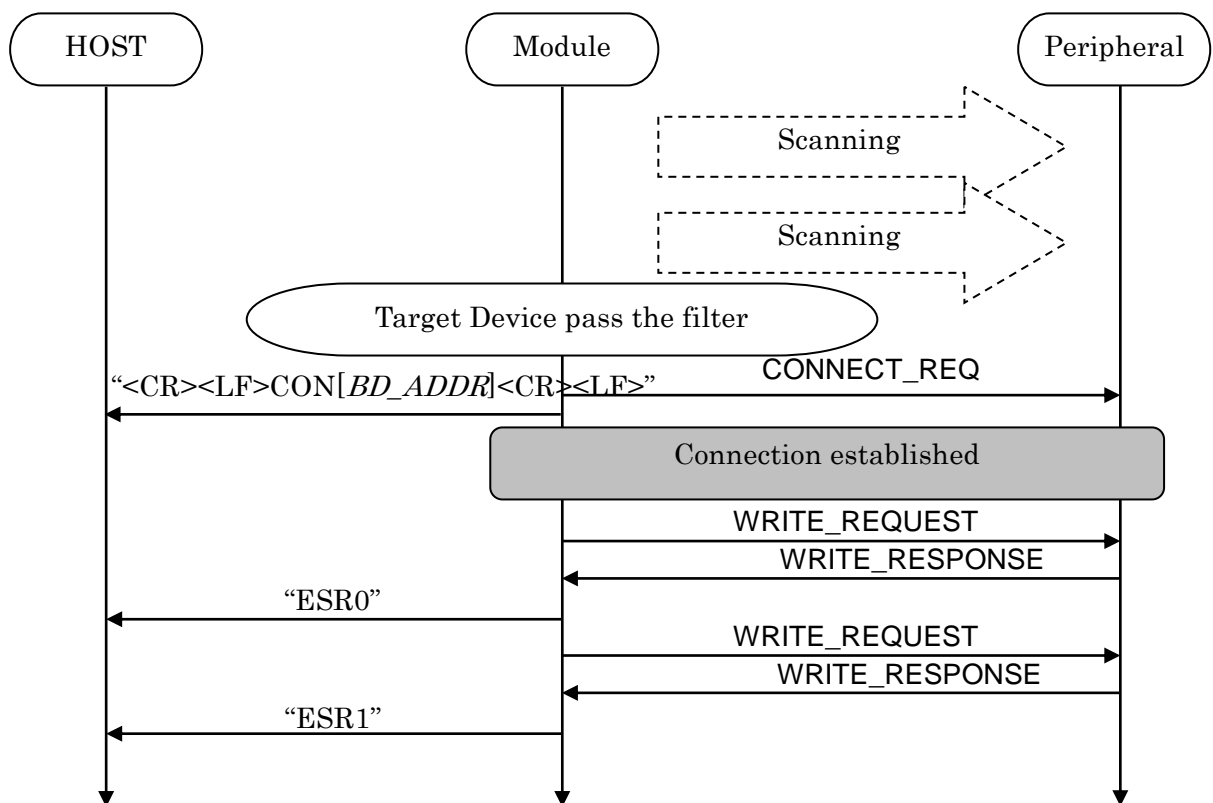

5.4.5. Sending & Receiving Data over a connected Link

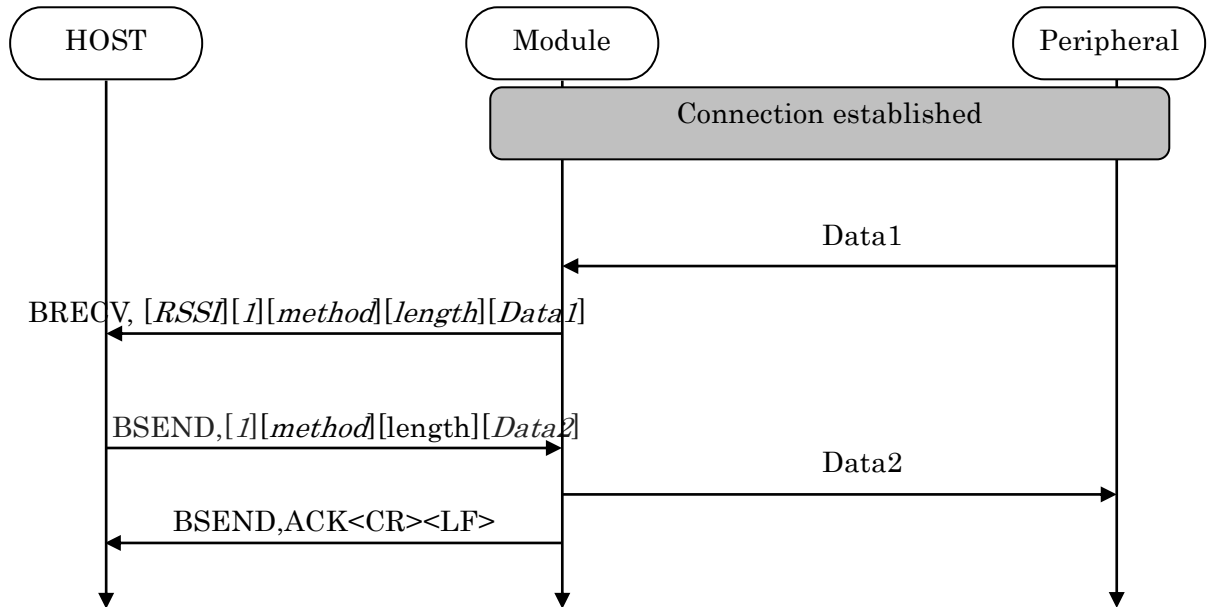

Max send a packet data size = 20bytes
 Max receive a packet data size = 20bytes

5.4.6. Disconnect

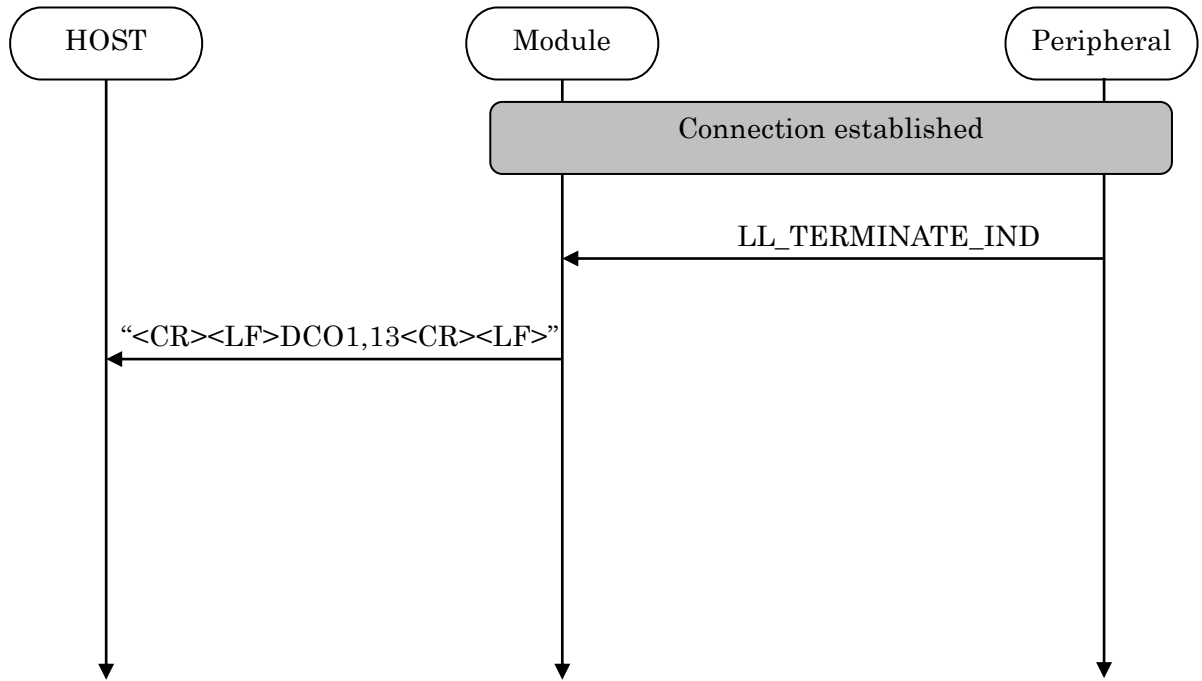

5.4.7. Pairing

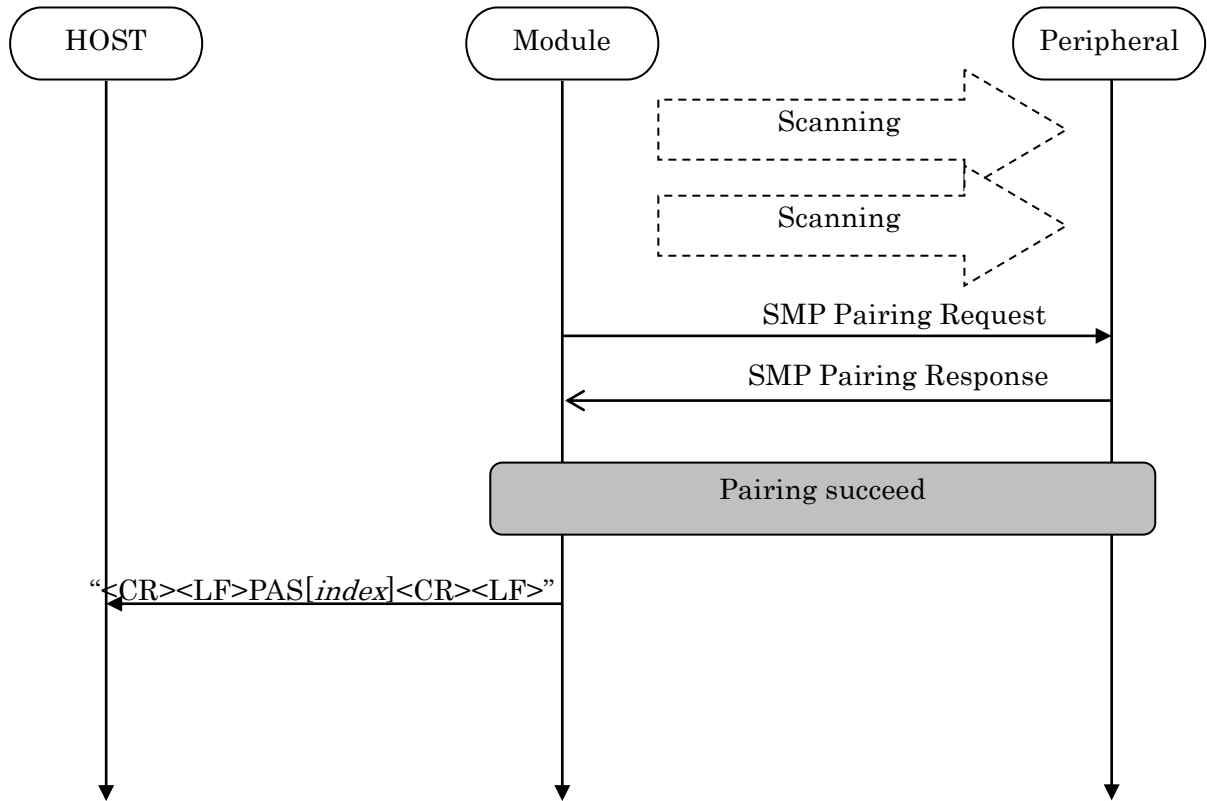

5.4.8. Disconnect Request (GPIO)

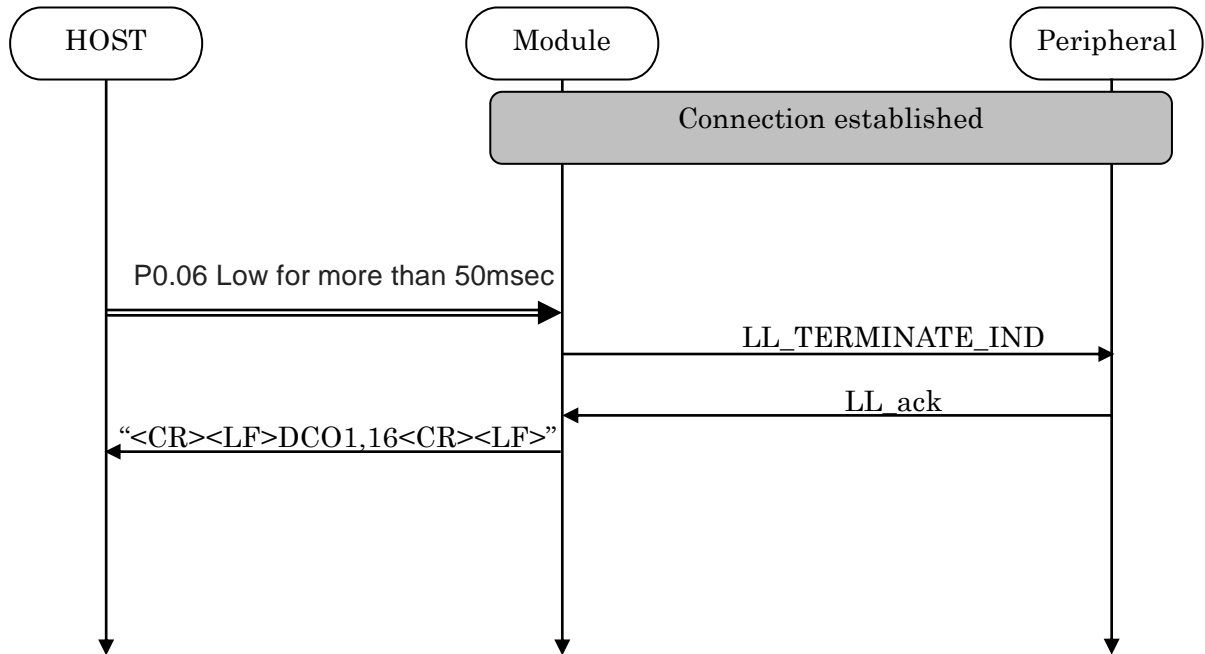

5.4.9. Disconnect Request (Command)

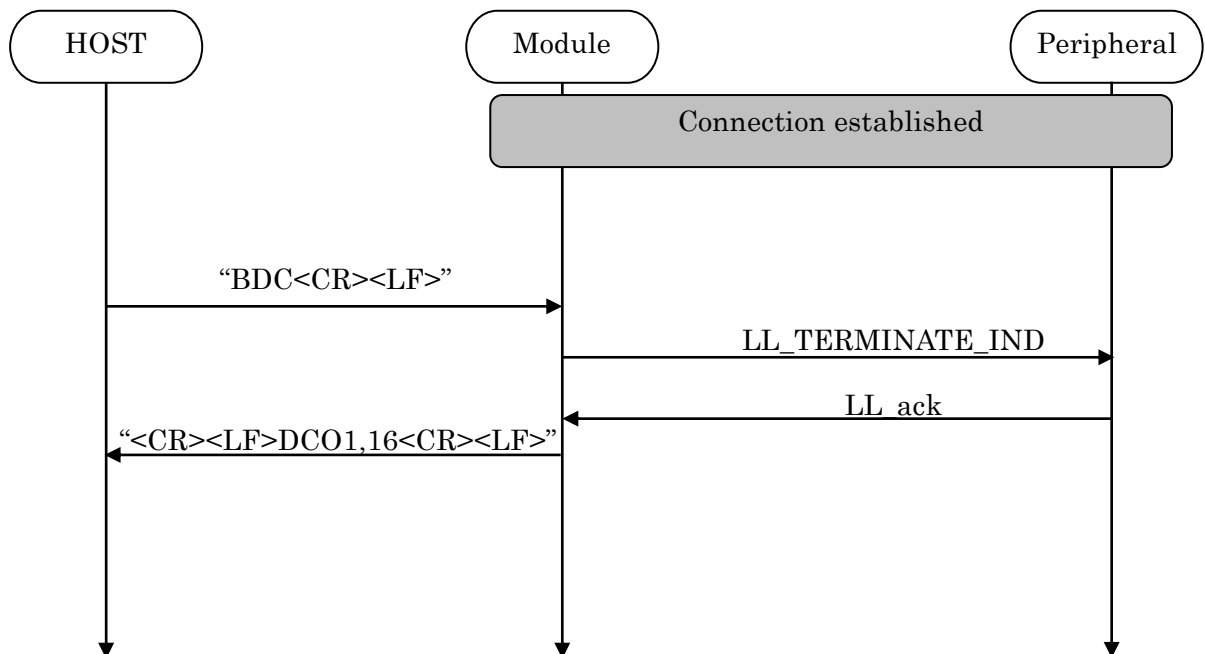

5.5 GPIO state and control

Pin Name	Input / Output	Description
P0.04	Input	Forced initialize(Central's Info)
		Request Sleep mode
P0.17	Input	Request Direct Test mode
		Request DFU mode
P0.05	Output	Module active/sleep indicate
P0.19	Output	State indication of module
		DFU indication
P0.06	Input	Disconnect request
		Resume from Power saving mode
		Request Direct Test mode
P0.21	Input	Sleep indication of host
		Resume from Power saving mode
P0.25	Output	Wake up request

5.5.1. Disconnect Request

P0.19

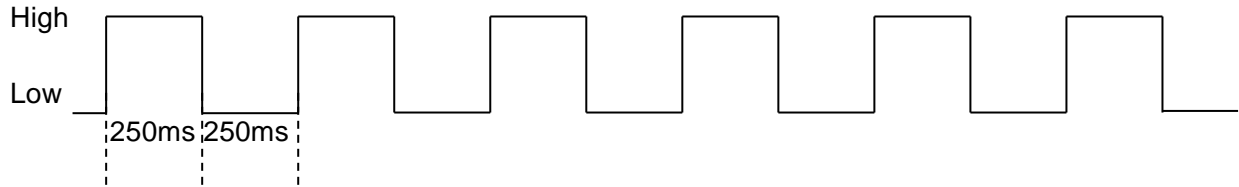

5.5.2. CONNECTED

P0.19 High

5.5.3. Disconnect & Standby

P0.19 Low

5.5.4. Forced initialize

Both Central and Peripheral user settings of the module return to a default value when make P0.04 Low at module startup.

After P0.04 Low, H/W reset or power restart is necessary.

The module start as Peripheral role.

5.5.5. Sleep mode request and indicate

P0.04

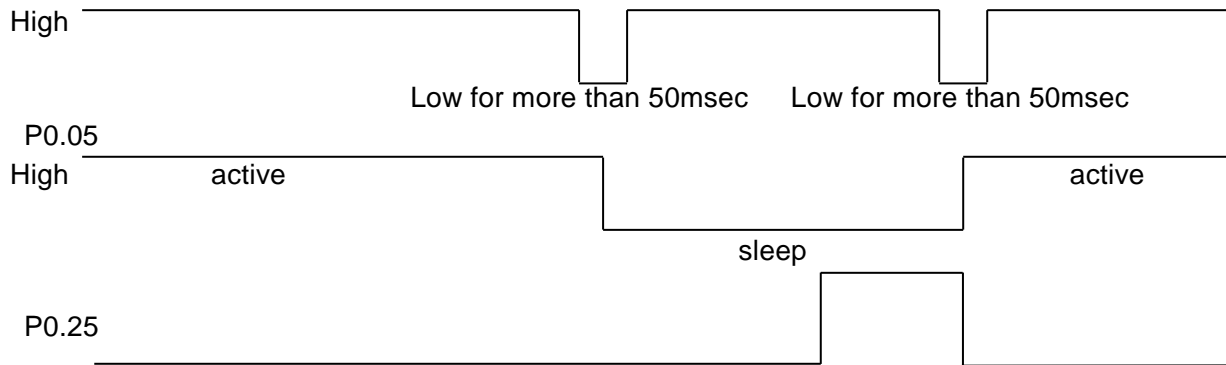

UART_TX



*** Buffer size : 128byte If the buffer is full, further data received is discarded without any events.**

5.6 Service

Primary Service

TAIYO YUDEN Original Service UUID :
0x442F1570-8A00-9A28-CBE1-E1D4212D53EB

Characteristic

TAIYO YUDEN Original Characteristic UUID :
0x442F1571-8A00-9A28-CBE1-E1D4212D53EB (Read, Notification)

TAIYO YUDEN Original Characteristic UUID :
0x442F1572-8A00-9A28-CBE1-E1D4212D53EB (Write no response)

TAIYO YUDEN Original Characteristic UUID :
0x442F1573-8A00-9A28-CBE1-E1D4212D53EB (Read, Indication)

TAIYO YUDEN Original Characteristic UUID :
0x442F1574-8A00-9A28-CBE1-E1D4212D53EB (Write)

*** GATT Server is implemented in Peripheral role of this software.**

5.7 UART configuration

RX_PIN : P0.03

TX_PIN : P0.01

CTS_PIN : P0.02

RTS_PIN : P0.00

Baud rate : depend on PSKEY_USER00 (default setting: 9600)

Data : 8 bit

Parity : none

Stop : 1 bit

Hardware flow control : Enabled (In case of DTM, flow control is disabled)

5.8 SWD (Serial Wire Debug)

SWDIO :

SWDCLK :

These pin are for FW debug and flash programming I/O.

We recommend your company set up these pin for rewriting the firmware.

5.9 Host wake-up sequence

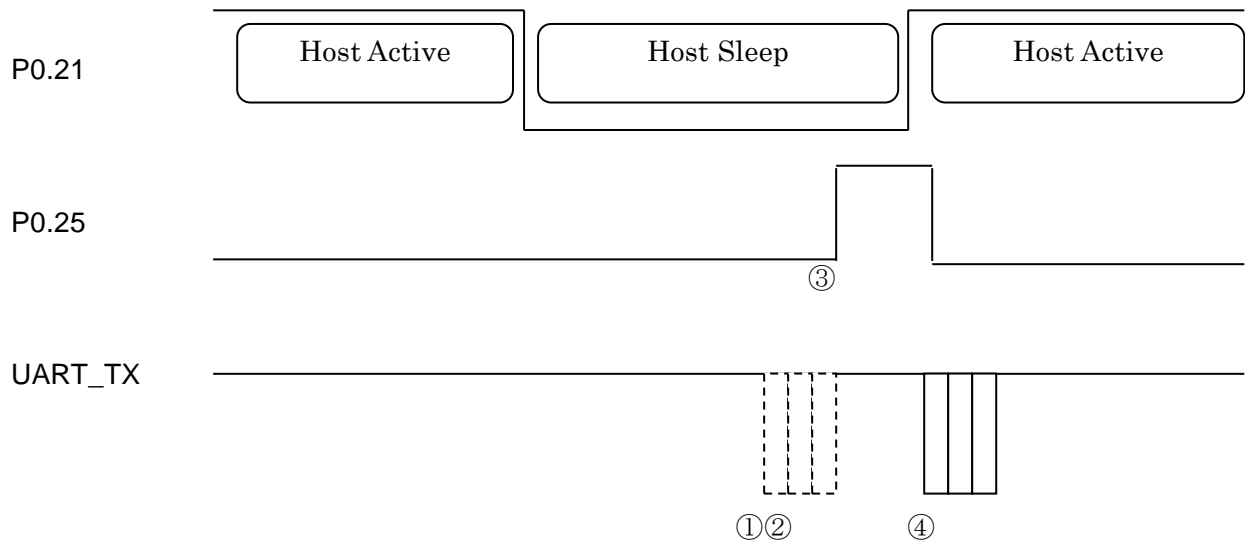

- ① Communication data or an event occurs in HOST Sleep.
- ② It waits until the host becomes active.
- ③ Module request to host wake-up via PIO.
- ④ If HOST becomes Active and Module is active (refer 5.5.5), module send communication data or event.

* **Buffer size : 128byte** If the buffer is full, further data received is discarded without any events.

5.10 DTM (Direct Test Mode)

5.10.1. Enter DTM and exit DTM (one-time)

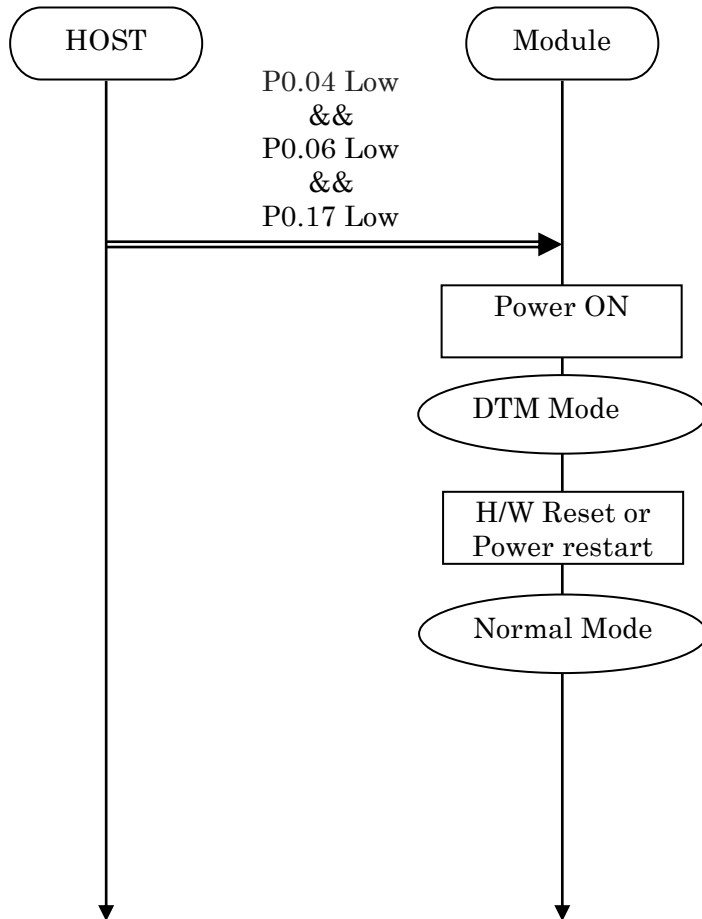

5.10.2. Enter DTM and exit DTM with UART command (permanent)

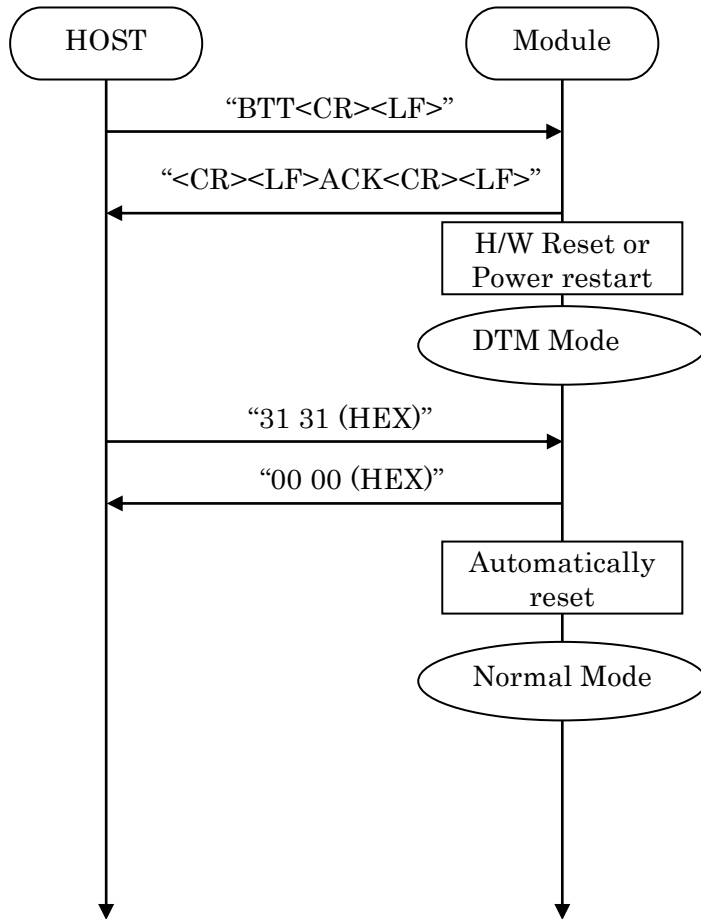

5.10.3. Enter DTM and exit DTM with GPIO command (permanent)

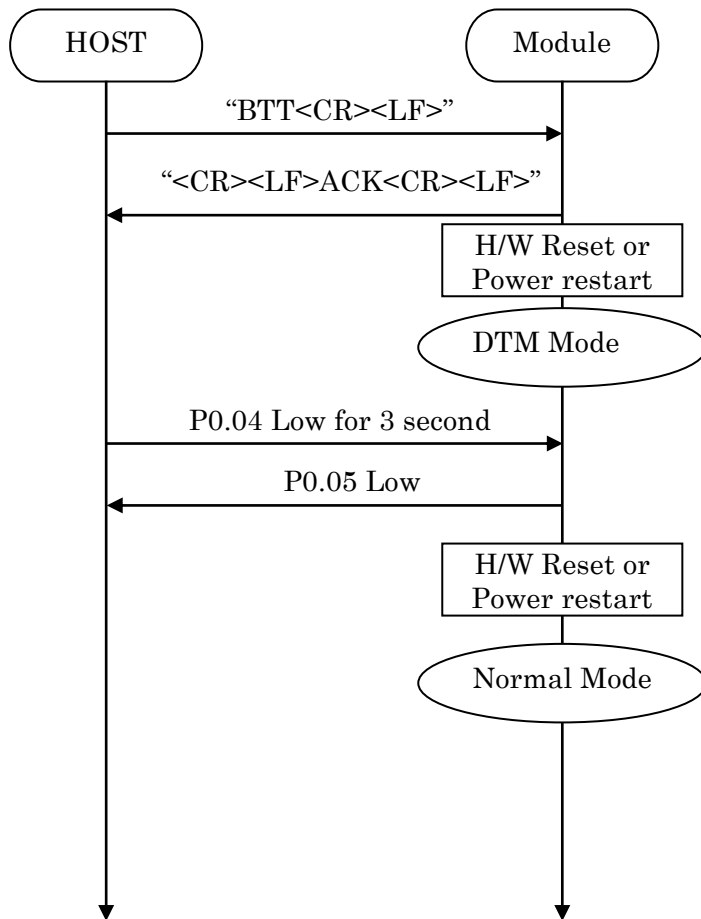

5.10.4. DTM Commands/Events

These commands/events are conforming to DTM of *Bluetooth*[®] specifications V4.0.

Please refer to *Bluetooth*[®] specifications V4.0.

(Core System Package [Low Energy Controller volume] Part F, Direct Test Mode)

EYSGCNAWY-VX

TAIYO YUDEN CO., LTD.

5.11 GPIO check

Host can inspect GPIO by special commands in DTM.

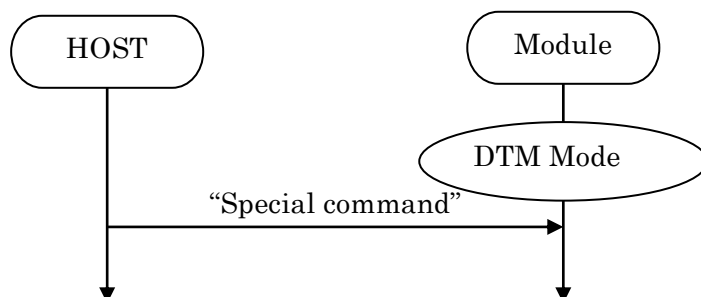

Command (Hex value)	Function	Response
32 30	It makes P0.05 Low.	00 00
32 31	It makes P0.05 High.	00 00
33 30	It makes P0.19 Low.	00 00
33 31	It makes P0.19 High.	00 00
34 30	It makes P0.25 Low.	00 00
34 31	It makes P0.25 High.	00 00
35 30	It makes P0.23 Low.	00 00
35 31	It makes P0.23 High.	00 00
39 39	It acquires state of Input Pin.	XX 00 00 XX: state Bit0: P0.04 (0:Low, 1:High) Bit1: P0.17 (0:Low, 1:High) Bit2: P0.06 (0:Low, 1:High) Bit3: P0.21 (0:Low, 1:High) Example 01 : P0.04 is High. Other Pin is Low. F: All Pin is High. B: P0.06 is Low. Other Pin is High.

5.12 Sleep Mode (SYSTEM ON)

This Sleep is available in during Scanning and Connection.
 UART I/F is not usable during Sleep.

5.12.1. Enter sleep mode

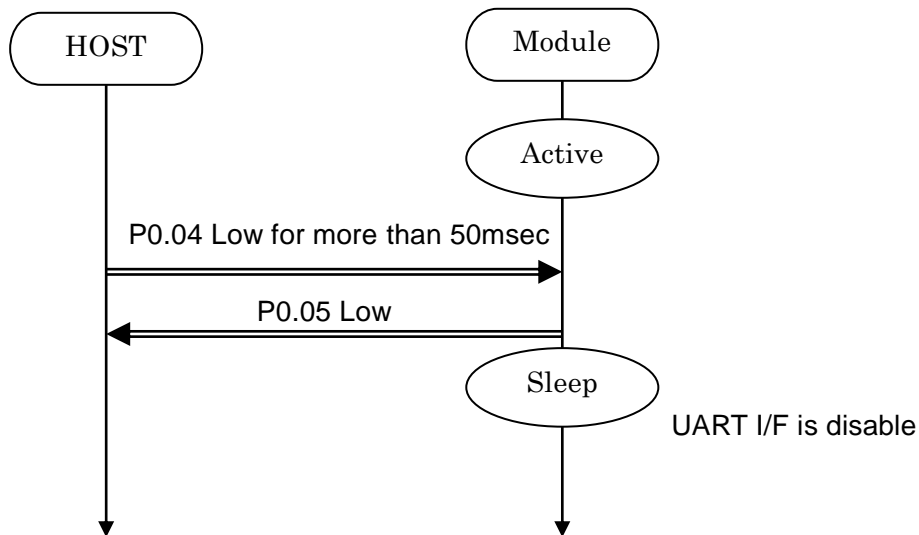

In case of UART data happen, the module notify to Host via P0.25.
 It is same as "Host wake-up".

5.12.2. Exit sleep mode

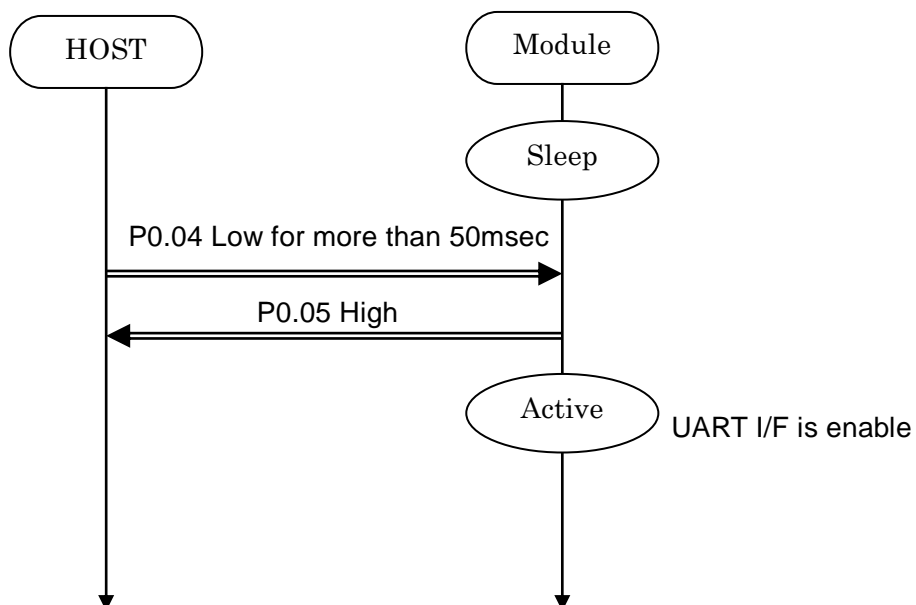

5.13 Power saving mode (SYSTEM OFF)

5.13.1. On startup (In case of PSKEY_USER09='0001')

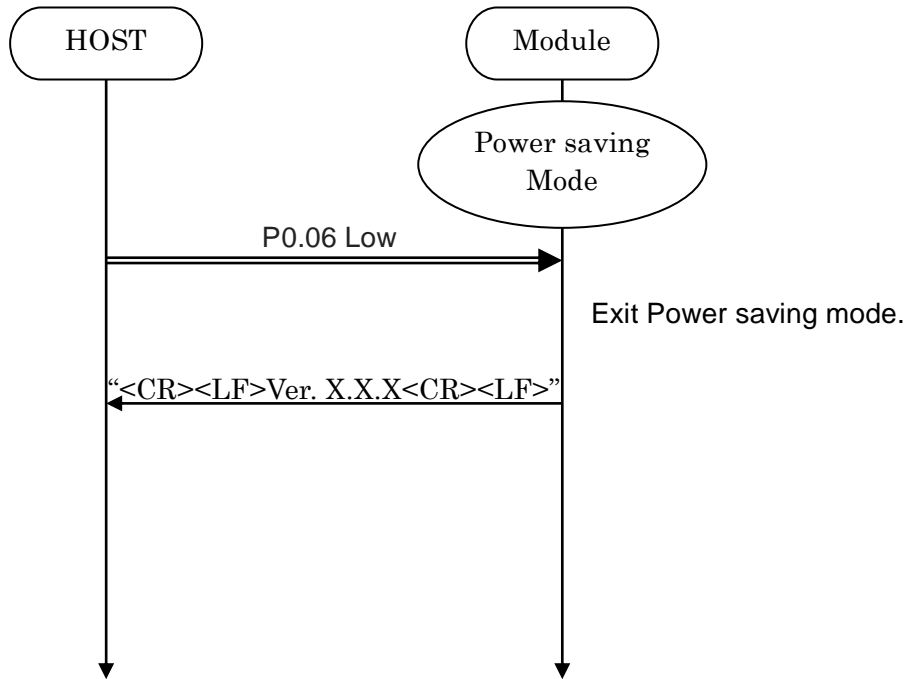

5.13.2. BSP command

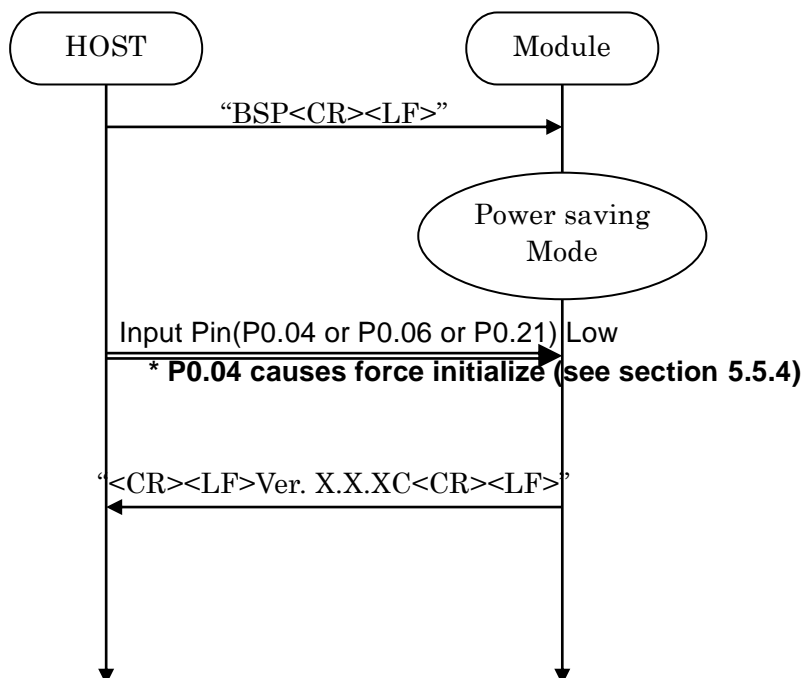

5.14 Device Firmware updates (DFU)

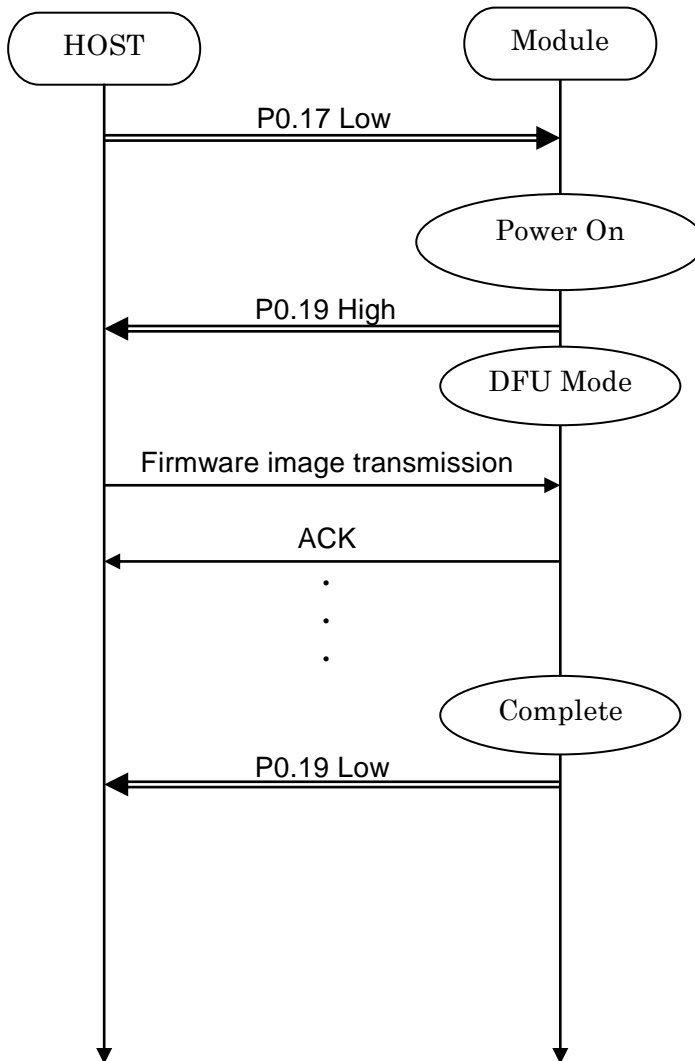

UART

Baud rate : 38400 bps
 Data : 8 bit
 Parity : none
 Stop : 1 bit
 Hardware flow control : Enabled

* Please contact TAIYO YUDEN when you use this function.

5.15 RSSI and Advertising data notification

Output RSSI value to UART according to PSKEY_USER14.

Format

In Advertising (only Central)

```
<CR><LF><RSSI (signed 4-digit)><,><BD Address (12-digit)><,>
<Data><CR><LF>
```

Example

```
// In Advertising (only Central)
-043,DF3F7BAF76F9,0123456789ABCDEF0123456789ABCDEF
-101,E647ADD614B0,0123456789ABCDEF0123456789ABCDEF
-044,DF3F7BAF76F9,0123456789ABCDEF0123456789ABCDEF
```

When UART baudrate is too low compared to RSSI notification rate, the output data may be incomplete.

In Sleep (5.5.5) and Host Sleep (5.9), RSSI notification is suspended.

EYSGCNAWY-VX

TAIYO YUDEN CO., LTD.

5.16 Filter

The filter for Scan (SC command).

In Connectable Scan, the module connect to the first device that passes the filter.

When the notification is enabled in PSKEY_USER14, Advertising data that passes the filter is output to UART.

5.16.1 PSKEY

Name	Filter	Default
PSKEY_USER15	Device name	Enabled Default device name : "TYSA-B 4.0.0"
PSKEY_USER16	Advertising data	Disabled
PSKEY_USER17	RSSI	-127 (Disabled)
PSKEY_USER18	BD Address	Disabled

By default, only device name filter "TYSA-B 4.0.0" is enabled.

5.16.2 STF command

Parameter 0:

0: Initialize all filter

1: Device name : PSKEY_USER15

Parameter 1:

Device name (ASCII 16byte Complete Local Name or Shortened Local Name)

Default target device name : "TYSA-B 4.0.0"

2: UUID 16byte : PSKEY_USER16

Parameter 1:

Index (ASCII 1-5)

Parameter 2:

UUID (Hex ASCII 32byte)

"0011" : iBeacon (UUID filter ON)

: Company ID must be set to iBeacon

"0021" : iBeacon (-ish) (UUID filter ON)

: You can use filters without having to set Company ID to iBeacon

3: BD Address (Allow) : PSKEY_USER18

Parameter 1:

Index (ASCII 1-3)

Parameter 2:

BD Address (Hex ASCII 12byte)

4: BD Address (Deny) : PSKEY_USER18

Parameter 1:

Index (ASCII 1-3)

Parameter 2:

BD Address (Hex ASCII 12byte)

TAIYO YUDEN CO., LTD.

EYSGCNAWY-VX

TAIYO YUDEN CO., LTD.

5: Company ID (Public BD Address) (Allow) : PSKEY_USER18

Parameter 1:

Company ID (Hex ASCII 6byte)

Please set 6 bytes from the beginning of the address

6: Company ID (Public BD Address) (Deny) : PSKEY_USER18

Parameter 1:

Company ID (Hex ASCII 6byte)

Please set 6 bytes from the beginning of the address

5.16.3 GTF commandParameter 0:**1: Device name**Response value:**Device name (ASCII 16byte Complete Local Name or Shortened Local Name)****2: UUID 16byte**Parameter 1:**Index (ASCII 1-5)**Response value:**UUID (Hex ASCII 32byte)****3: BD Address (Allow)**Parameter 1:**Index (ASCII 1-3)**Response value:**BD Address (Hex ASCII 12byte)****4: BD Address (Deny)**Parameter 1:**Index (ASCII 1-3)**Response value:**BD Address (Hex ASCII 12byte)****5: Company ID (Allow)**Response value:**Company ID (Hex ASCII 6byte)****6: Company ID (Deny)**Response value:**Company ID (Hex ASCII 6byte)**

EYSGCNAWY-VX

TAIYO YUDEN CO., LTD.

5.17 LE Secure Connection 5.17.1 Numeric Comparison

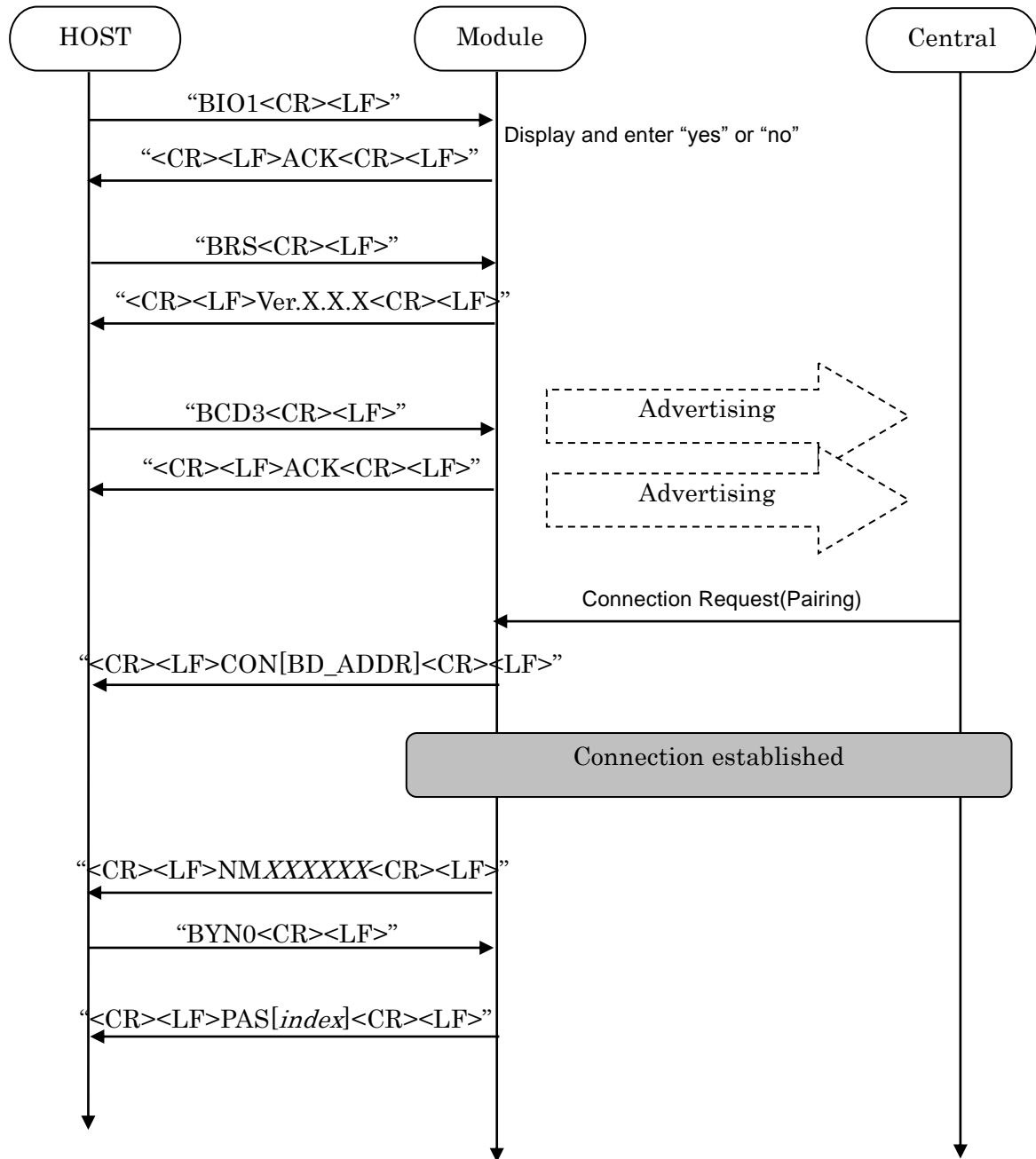

5.17.2 Out of Band

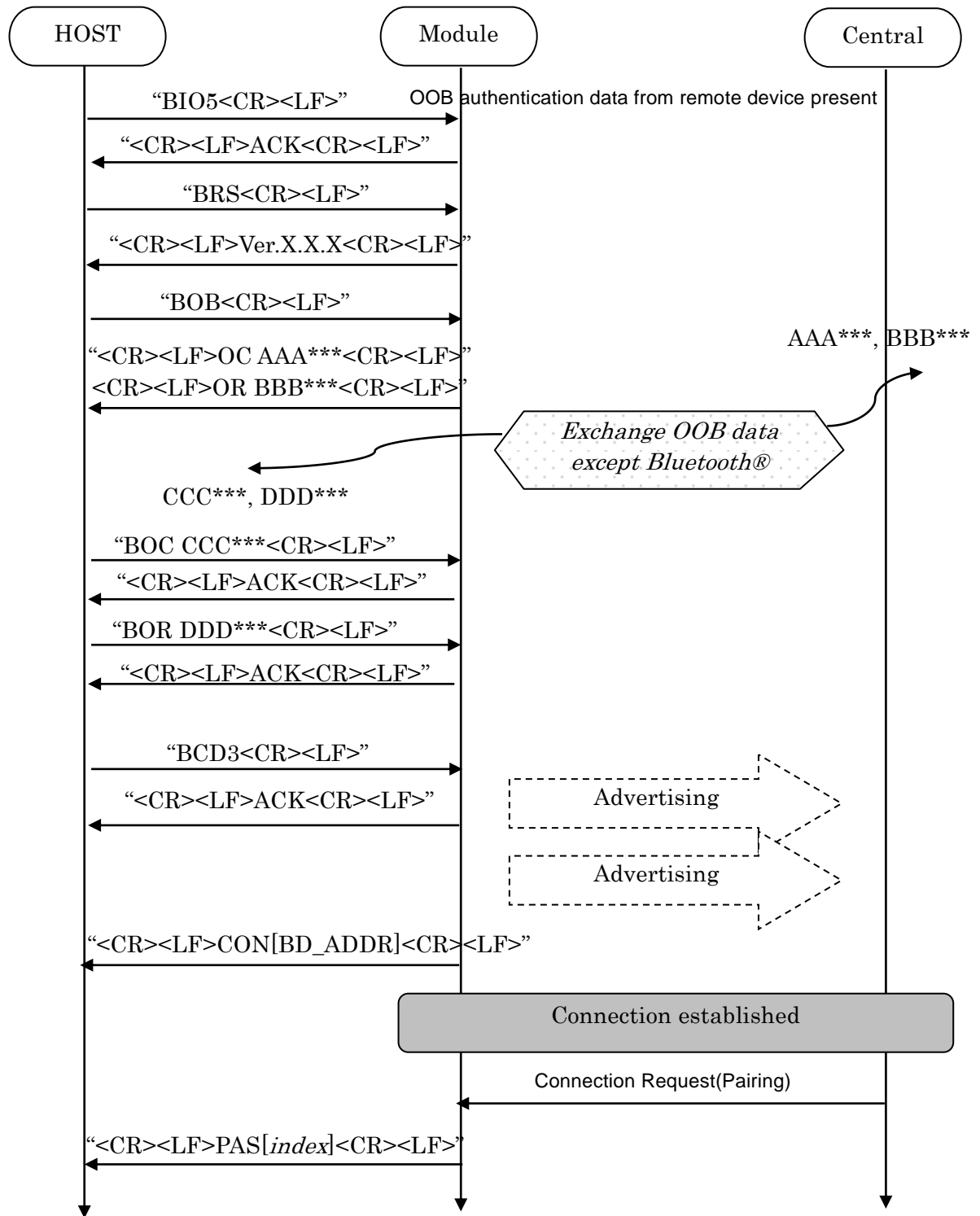

EYSGCNAWY-VX

TAIYO YUDEN CO., LTD.

5.17.3 Passkey Entry, Peripheral Displays

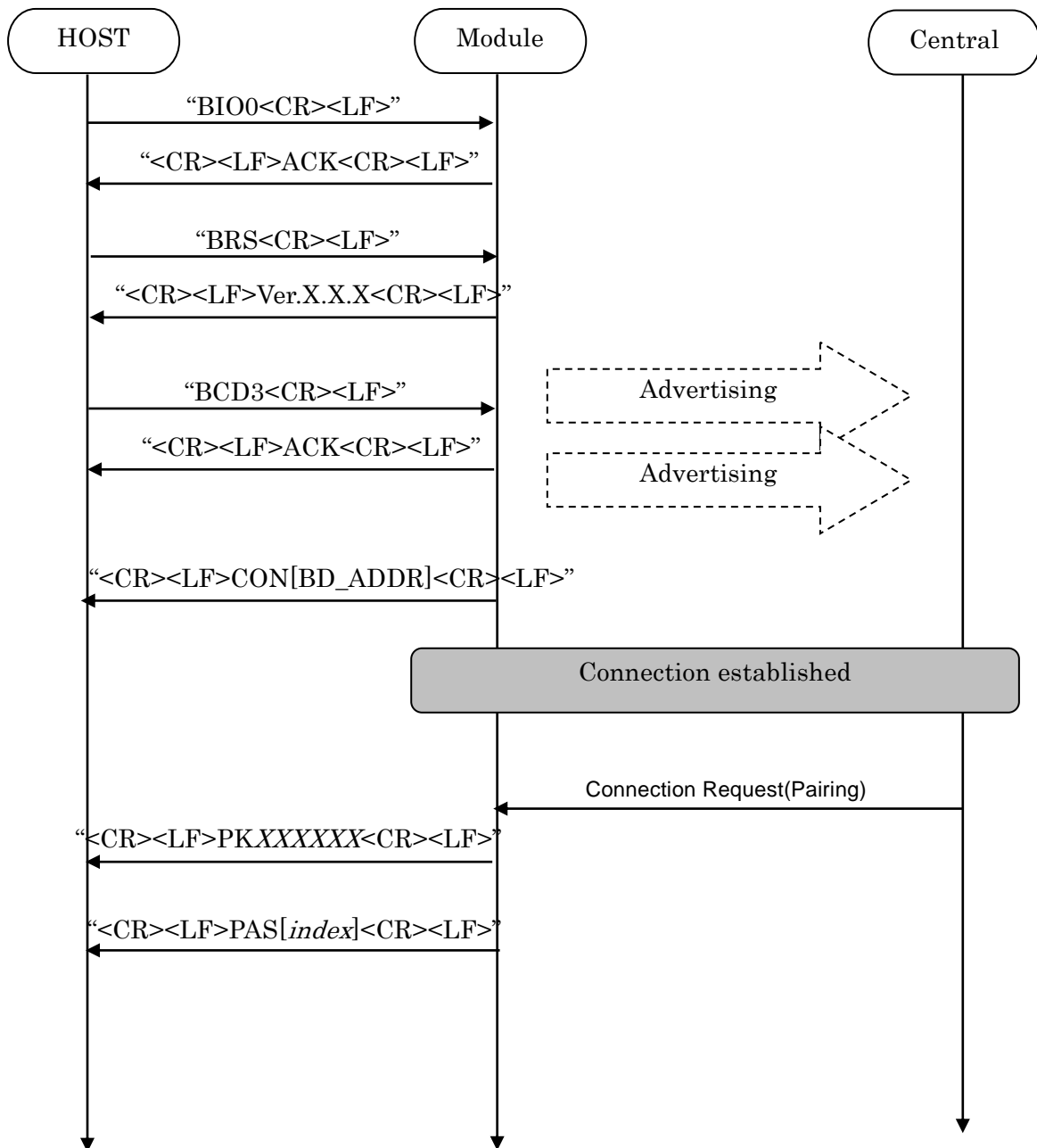

5.17.4 Passkey Entry, User Inputs on Peripheral

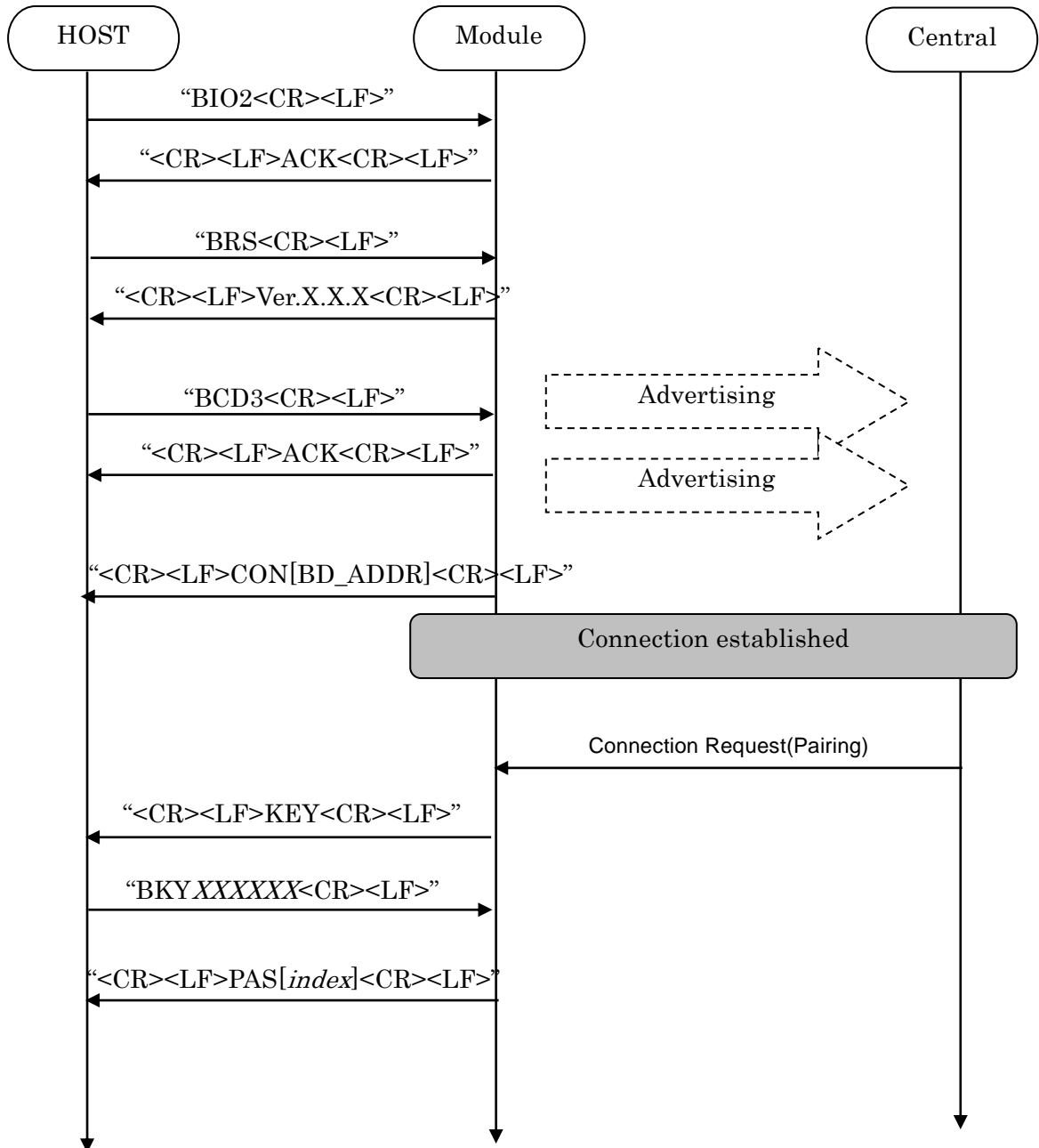

EYSGCNAWY-VX

TAIYO YUDEN CO., LTD.

5.17.5 Just Works

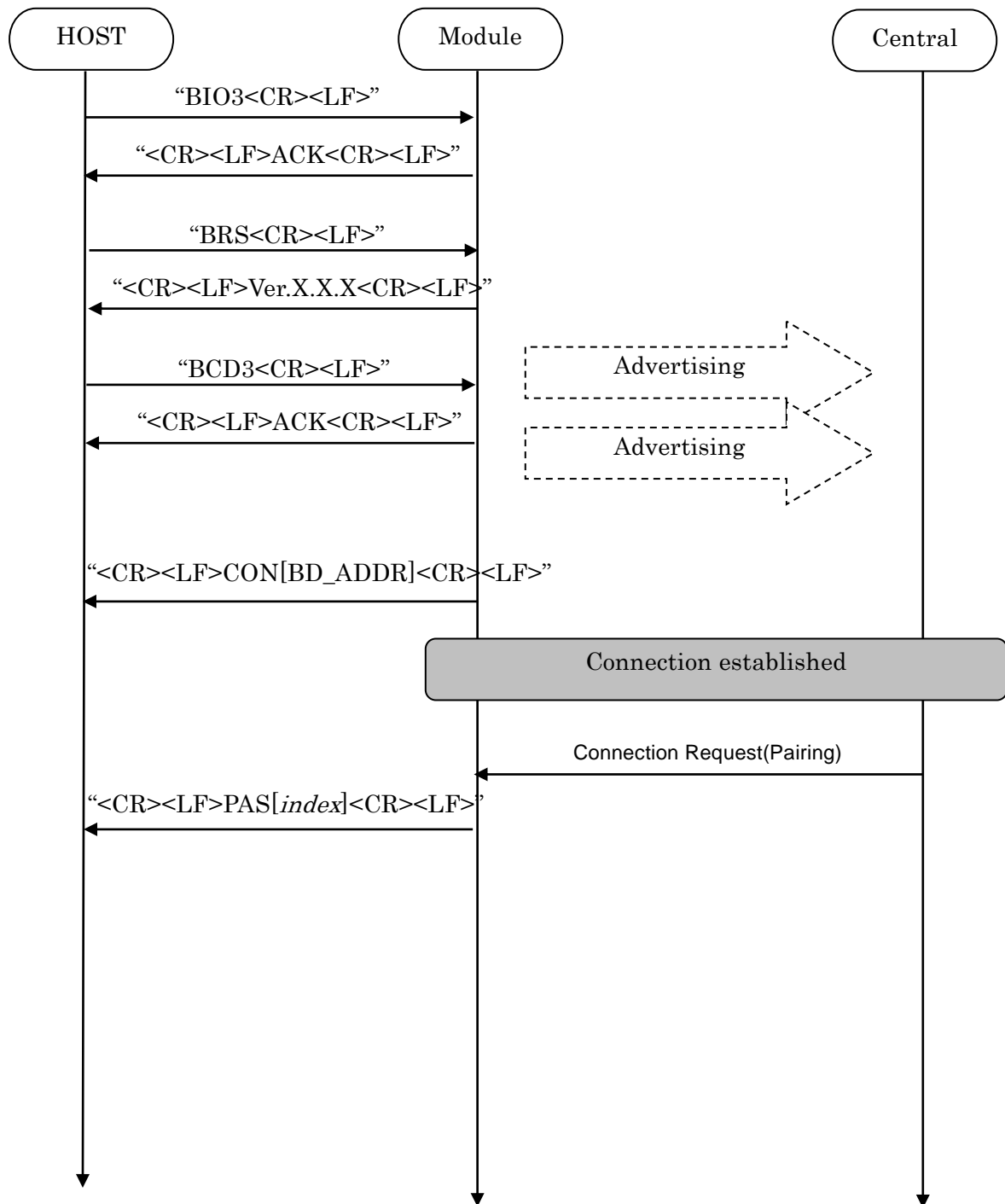

5.18 Notices

1. This application uses Softdevice S130 V2.0.1 for Central.
2. Central role of this application doesn't support IRK.
Therefore, if Peripheral uses private random address, pairing is performed every time and bonding is not performed.
3. ST2 command accepts only Static Address (BLUETOOTH SPECIFICATION Version 4.2 [Vol 6 PartB] 1.3.2.1). A static address is a 48-bit randomly generated address and shall meet the following requirements.
 - The two most significant bits of the static address shall be equal to '1'.
 - All bits of the random part of the static address shall not be equal to '1'.
 - All bits of the random part of the static address shall not be equal to '0'.
4. The buffer size for Sleep (Section 5.5.5) is 128byte.
If the buffer is full, further data received is discarded without any events.
5. The buffer size for Host wake-up (Section 5.9) is 128byte.
If the buffer is full, further data received is discarded without any events.
6. TT command set the flag for Direct Test Mode.
To reset the flag, input "31 31(HEX)" or set GPIO P0.04 Low for 3 second.
Until the flag is reset, the module keeps DTM even after system restart.
7. Do not turn the power off while the data is written to FLASH memory with ST4/ST5/STF/DS/DD/TT command. It takes up to 500ms to complete the writing process asynchronously after ACK response.
8. The connection timer is 160 seconds.
This timer starts when the module attempts to establish the connection to target device and stops when Characteristic 0x1571 (Notification) in Peripheral's GATT Server is enabled.
9. If connection interval is too long, the pairing fails and NAK07 because of SMP TIMEOUT (BLUETOOTH SPECIFICATION Version 4.2 [Vol 3, Part H] 3.4).
The connection parameters of Central is used until Connection parameter update.
To use long connection interval, set connection parameters in Peripheral side and wait Connection update request.
10. If you want to use PSKEY_USER16 filter, you need to set Advertising data(Company ID) to iBeacon. Please refer to Chapter 4.16 for the value of advertising data
11. It takes about 10 seconds to initialize the FLASH area when executing DFU. Please start communication after Pin0.19 goes High after completion of initialization.

その他、注意事項について (Precautions)

- 弊社製品のご使用に際しては、使用する機器に実装された状態および実際の使用環境での評価および確認を必ず行ってください。
- 当仕様書に記載の製品は、一般的な電子機器【AV機器、OA機器、家電製品、事務機器、情報・通信機器（携帯電話、パソコンなど）】で使用されることを意図されています。したがって、生命または身体に直接危害を及ぼす可能性のある機器【輸送用機器（自動車駆動制御装置、列車制御装置、船舶制御装置など）、交通用信号機器、防災機器、医療機器（国際分類クラスⅠ、Ⅱ、Ⅲ）、公共性の高い情報通信機器（電話交換機、電話・無線・放送などの基地局）】などへのご使用をご検討の場合は、必ず事前に弊社までお問い合わせをお願いします。
また、高度の安全性や信頼性が求められる機器【宇宙用機器、航空用機器、医療機器（国際分類クラスⅣ）、原子力用制御機器、海底用機器、軍事用機器など】につきましては、弊社製品をご使用されないようお願いします。
なお、一般的な電子機器においても安全性や信頼性の要求が高い機器、回路などに弊社製品をご使用になる場合には、十分な安全性評価を実施され、必要に応じて設計時に保護回路などを追加していただくことをお勧めします。
弊社の書面による事前の承諾を得ることなく、前述の弊社への問い合わせが必要な機器または弊社が使用を禁止する機器に当仕様書に記載の製品を使用したことによりお客様または第三者に生じた損害に関して、弊社は一切の責任を負いかねますのでご了承ください。
- 当仕様書に記載の情報は、製品の代表的動作・応用を説明するためのものであり、その使用に際して弊社および第三者の知的財産権その他の権利に対する保証または実施権の許諾を行うものではありません。
- 弊社製品の保証範囲につきましては、納入された弊社製品単体の保証に限られ、弊社製品の故障や瑕疵から誘発される損害に関して、弊社は一切の責任を負いかねますのでご了承ください。ただし、取引基本契約書、品質保証協定書など別途書面による契約が締結されている場合は、その内容にしたがって保証させていただきます。
- 当仕様書に記載内容につきましては、弊社の営業所・販売子会社・販売代理店（いわゆる「正規販売チャンネル」）からご購入いただいた弊社製品に適用します。上記以外からご購入いただいた弊社製品に関しては適用対象外とさせていただきますのでご了承ください。
- 輸出注意事項
当仕様書に記載の製品の一部には、輸出の際に「外国為替及び外国貿易法」並びに米国の輸出管理関連法規などの規制をご確認の上、必要な手続きをお取りいただく必要のある製品があります。ご不明な場合には弊社までお問い合わせください。
- Please conduct validation and verification of our products in actual condition of mounting and operating environment before using our products.
- The products listed in this specification are intended for use in general electronic equipment (e.g., AV equipment, OA equipment, home electric appliances, office equipment, information and communication equipment including, without limitation, mobile phone, and PC). Please be sure to contact TAIYO YUDEN for further information before using the products for any equipment which may directly cause loss of human life or bodily injury (e.g., transportation equipment including, without limitation, automotive powertrain control system, train control system, and ship control system, traffic signal equipment, disaster prevention equipment, medical equipment classified as Class I, II or III by IMDRF, highly public information network equipment including, without limitation, telephone exchange, and base station).
Please do not incorporate our products into any equipment requiring high levels of safety and/or reliability (e.g., aerospace equipment, aviation equipment, medical equipment classified as Class IV by IMDRF, nuclear control equipment, undersea equipment, military equipment).
When our products are used even for high safety and/or reliability-required devices or circuits of general electronic equipment, it is strongly recommended to perform a thorough safety evaluation prior to use of our products and to install a protection circuit as necessary.
Please note that unless you obtain prior written consent of TAIYO YUDEN, TAIYO YUDEN shall not be in any way responsible for any damages incurred by you or third parties arising from use of the products listed in this specification for any equipment requiring inquiry to TAIYO YUDEN or prohibited for use by TAIYO YUDEN as described above.
- Information contained in this specification is intended to convey examples of typical performances and/or applications of our products and is not intended to make any warranty with respect to the intellectual property rights or any other related rights of TAIYO YUDEN or any third parties nor grant any license under such rights.
- Please note that the scope of warranty for our products is limited to the delivered our products themselves and TAIYO YUDEN shall not be in any way responsible for any damages resulting from a fault or defect in our products. Notwithstanding the foregoing, if there is a written agreement (e.g., supply and purchase agreement, quality assurance agreement) signed by TAIYO YUDEN and your company, TAIYO YUDEN will warrant our products in accordance with such agreement.

HQ-BK-002_02

- The contents of this specification are applicable to our products which are purchased from our sales offices or authorized distributors (hereinafter "TAIYO YUDEN's official sales channel"). Please note that the contents of this specification are not applicable to our products purchased from any seller other than TAIYO YUDEN's official sales channel.

- Caution for Export

Some of our products listed in this specification may require specific procedures for export according to "U.S. Export Administration Regulations", "Foreign Exchange and Foreign Trade Control Law" of Japan, and other applicable regulations. Should you have any questions on this matter, please contact our sales staff.