

**WKSEGVDXG**

# ワイヤレス LAN / Bluetooth<sup>®</sup> モジュール 評価キット

(For WYSEGVDXG)

WKSEGVDXG



この評価キットは、実験検証用であり、品質を保証するものではありません。  
また、評価キットに使用している回路や部品、ソフトウェアは最新の物ではないことがあります。

# WKSEGVDXG

---

注意:このモジュールは、日本の輸出管理下にあるデバイスドライバが必要です。お客様の国やアプリケーション(武器など)によっては、これらのドライバをすべてのお客様に提供することができない場合があります。

詳細はお近くの太陽誘電営業所までお問い合わせください。

[www.ty-top.com](http://www.ty-top.com).

# WKSEGVDXG

## 目次

紹介.....	4
適合モジュール.....	4
付属品.....	4
接続例.....	4
評価ボードのレイアウト.....	5
評価ボードピンの説明.....	5
評価ボードの部品リスト.....	6-7
評価ボードの回路図.....	8-10

## Rev. Records

May.22.2019> Ver.1.0 Release

Jul.02.2019> Ver.1.1 Update

Jun.19.2020> Ver.1.2 Update

# WKSEGVDXG

## 紹介

本評価キットは、太陽誘電が開発・販売する無線 LAN/**Bluetooth**®モジュールの通信テスト用に開発されたものです。

本評価キットにより、太陽誘電の無線 LAN/**Bluetooth**®モジュールの通信テストを容易に行うことができます。

## 適合モジュール

WYSEGVDXG

## 付属品

1	Evaluation Board (WBSEGVDXG)	1 piece
2	DC Power Cable	1 piece
3	ESPRESSObin	1 piece
4	AC Adapter	1 piece
5	USB Memory	1 piece
6	USB Cable	1 piece
7	SD – Micro SD Conversion Cable	1 piece

## 接続例(SDIO)

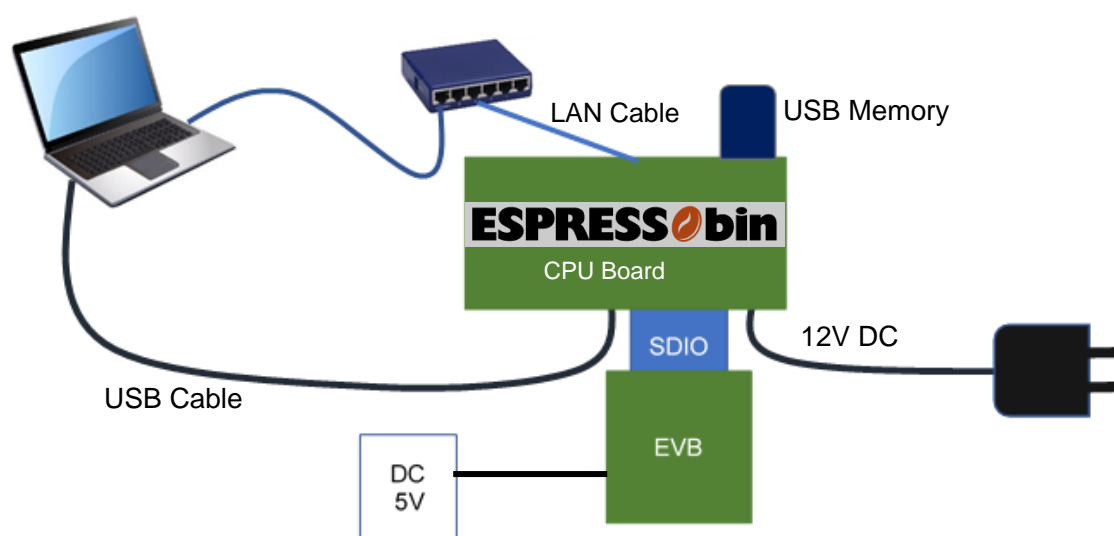

# WKSEGVDXG

## 評価ボードレイアウト

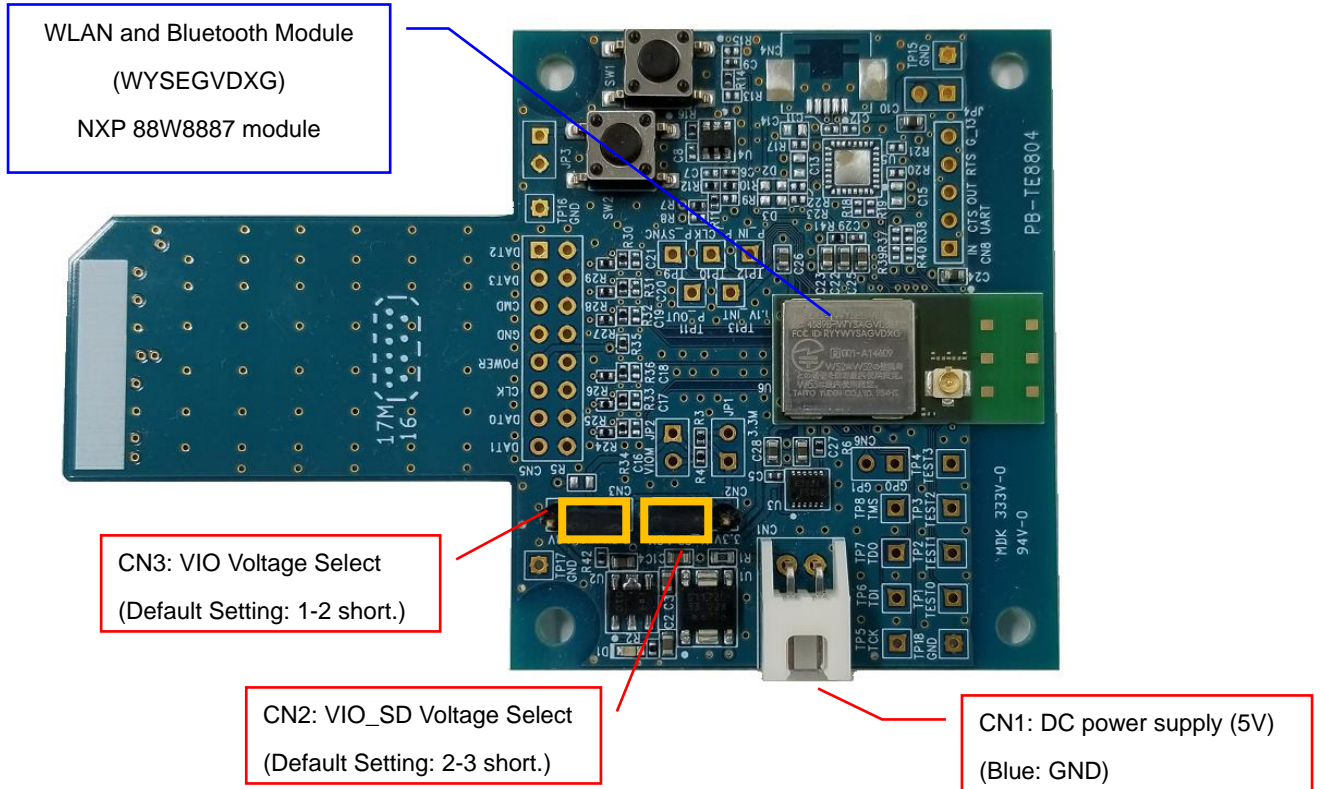

## 評価ボードピンの説明

### WBSEGVDXG (TE8804)

CN1: DC Power Supply

No.	Pin name	Direction	Description
1	5V	Input	5.0V input.
2	GND	GND	Ground

CN2: VIO\_SD Voltage Select (Default Setting: 2-3 short.)

No.	Pin name	Direction	Description
1	3.3V	Output	3.3V output.
2	VIO_SD	Input	Input for VIO_SD.
3	1.8V	Output	1.8V output.

CN3: VIO Voltage Select (Default Setting: 1-2 short.)

No.	Pin name	Direction	Description
1	3.3V	Output	3.3V output.
2	VIO	Input	Input for VIO.
3	1.8V	Output	1.8V output.

**WKSEGVDXG**

## 評価ボードの部品リスト

**WBSEGVDXG (TE8804)**

Ref Name	Description	Parts name	Supplier
U1	IC(LDO 3.3V)	S-1172B33-E6T1G	SII or equivalent
U2	IC(LDO1.8V)	S-1170B18UC-OTDTF	SII or equivalent
U3	IC(32.768kHz clock)	SG-3030LC	EPSON or equivalent
U4	IC	TPS3808G01DBVT	TI or equivalent
U5	N.M.	N.M.	
U6	Module	WYSEGVDXG	TAIYO YUDEN
SW1	SWITCH	HP03-15AFKP2	NKK SWITCHES or equivalent
SW2	SWITCH	HP03-15AFKP2	NKK SWITCHES or equivalent
CN1	CONNECTOR	S2B-XH-A	JST or equivalent
CN2	CONNECTOR	PIN_HEADER_S3	
CN3	CONNECTOR	PIN_HEADER_S3	
CN4-CN8	N.M.	N.M.	
JP1-JP4	N.M.	N.M.	
C1	CAPACITOR	LMK107 BJ475KA	TAIYO YUDEN
C2	CAPACITOR	LMK107 BJ475KA	TAIYO YUDEN
C3	CAPACITOR	LMK107 BJ475KA	TAIYO YUDEN
C4	CAPACITOR	LMK107 BJ475KA	TAIYO YUDEN
C5	CAPACITOR	TMK105 BJ104KV	TAIYO YUDEN
C6	CAPACITOR	TMK105 BJ104KV	TAIYO YUDEN
C7-C8	N.M.	N.M.	
C9	CAPACITOR	TMK105 BJ104KV	TAIYO YUDEN
C10	CAPACITOR	JMK107 BJ106MA	TAIYO YUDEN
C11-C21	N.M.	N.M.	
C22	CAPACITOR	JMK107 BJ106MA	TAIYO YUDEN
C23	CAPACITOR	JMK107 BJ106MA	TAIYO YUDEN
C24	CAPACITOR	JMK107 BJ106MA	TAIYO YUDEN
C25	CAPACITOR	JMK107 BJ106MA	TAIYO YUDEN
C26	CAPACITOR	JMK107 BJ106MA	TAIYO YUDEN
C27	CAPACITOR	JMK107 BJ106MA	TAIYO YUDEN
C28	CAPACITOR	JMK107 BJ106MA	TAIYO YUDEN
C29	CAPACITOR	UMK105 CH100CV	TAIYO YUDEN
R1	RESISTOR	MCR03 EZP J000	ROHM or equivalent
R2	RESISTOR	MCR01 MZP J 470	ROHM or equivalent

**WKSEGVDXG**

Ref Name	Description	Parts name	Supplier
R3	RESISTOR	MCR01 MRT J000	ROHM or equivalent
R4	RESISTOR	MCR01 MRT J000	ROHM or equivalent
R5	N.M.	N.M.	
R6	RESISTOR	MCR01 MRT J000	ROHM or equivalent
R7	N.M.	N.M.	
R8	RESISTOR	MCR01 MRT J000	ROHM or equivalent
R9	N.M.	N.M.	
R10	RESISTOR	MCR01 MRT J000	ROHM or equivalent
R11	RESISTOR	MCR01 MZP J104	ROHM or equivalent
R12	RESISTOR	MCR01 MZP J104	ROHM or equivalent
R13	N.M.	N.M.	
R14	RESISTOR	MCR01 MRT J000	ROHM or equivalent
R15	N.M.	N.M.	
R16	RESISTOR	MCR01 MRT J000	ROHM or equivalent
R17-R23	N.M.	N.M.	
R24	RESISTOR.	MCR01 MZP J220	ROHM or equivalent
R25	RESISTOR.	MCR01 MZP J220	ROHM or equivalent
R26	RESISTOR.	MCR01 MZP J220	ROHM or equivalent
R27	RESISTOR.	MCR01 MZP J220	ROHM or equivalent
R28	RESISTOR.	MCR01 MZP J220	ROHM or equivalent
R29	RESISTOR.	MCR01 MZP J220	ROHM or equivalent
R30	RESISTOR	MCR01 MRT J473	ROHM or equivalent
R31	RESISTOR	MCR01 MRT J473	ROHM or equivalent
R32	RESISTOR	MCR01 MRT J473	ROHM or equivalent
R33	RESISTOR	MCR01 MRT J473	ROHM or equivalent
R34	RESISTOR	MCR01 MRT J473	ROHM or equivalent
R35	CAPACITOR	TMK105 BJ104KV	TAIYO YUDEN
R36-R40	N.M.	N.M.	
R41	RESISTOR	MCR01 MZP J104	ROHM or equivalent
R42	N.M.	N.M.	
D1	LED	SML-D12M	ROHM or equivalent
D2-D3	N.M.	N.M.	
TP1-13	N.M.	N.M.	
TP15-18	N.M.	N.M.	

REV	ECO	APPROVED	DESCRIPTION	DATE

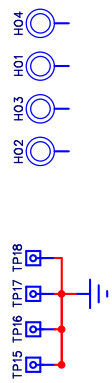
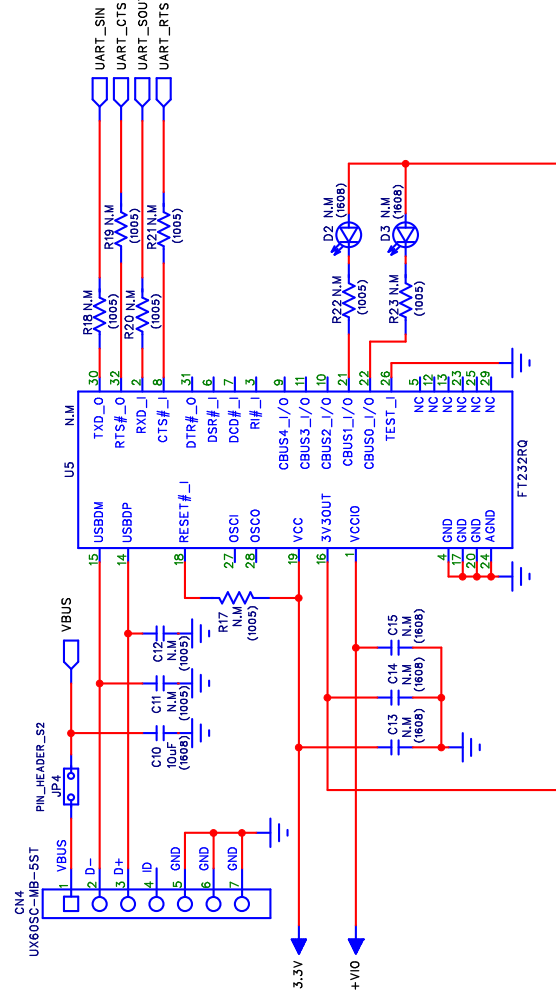
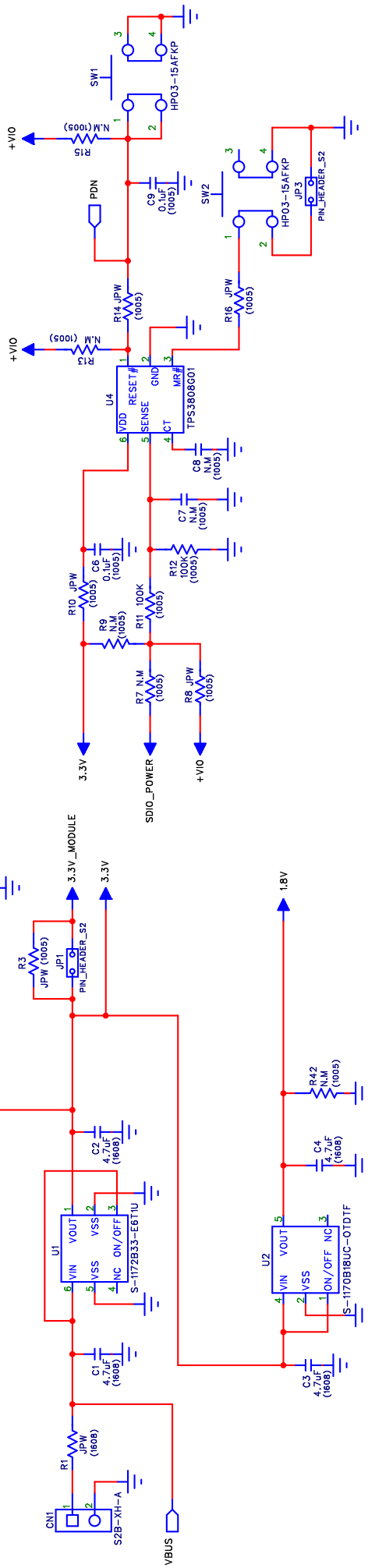

APPROVED:	Title	Document No.
CHECKED :	Circuit schematic	HD-MC-
DRAWN :		BTE8804
DESIGNED :		

TAIYO YUDEN CO.,LTD.

REV	ECO	APPROVED	DESCRIPTION	DATE

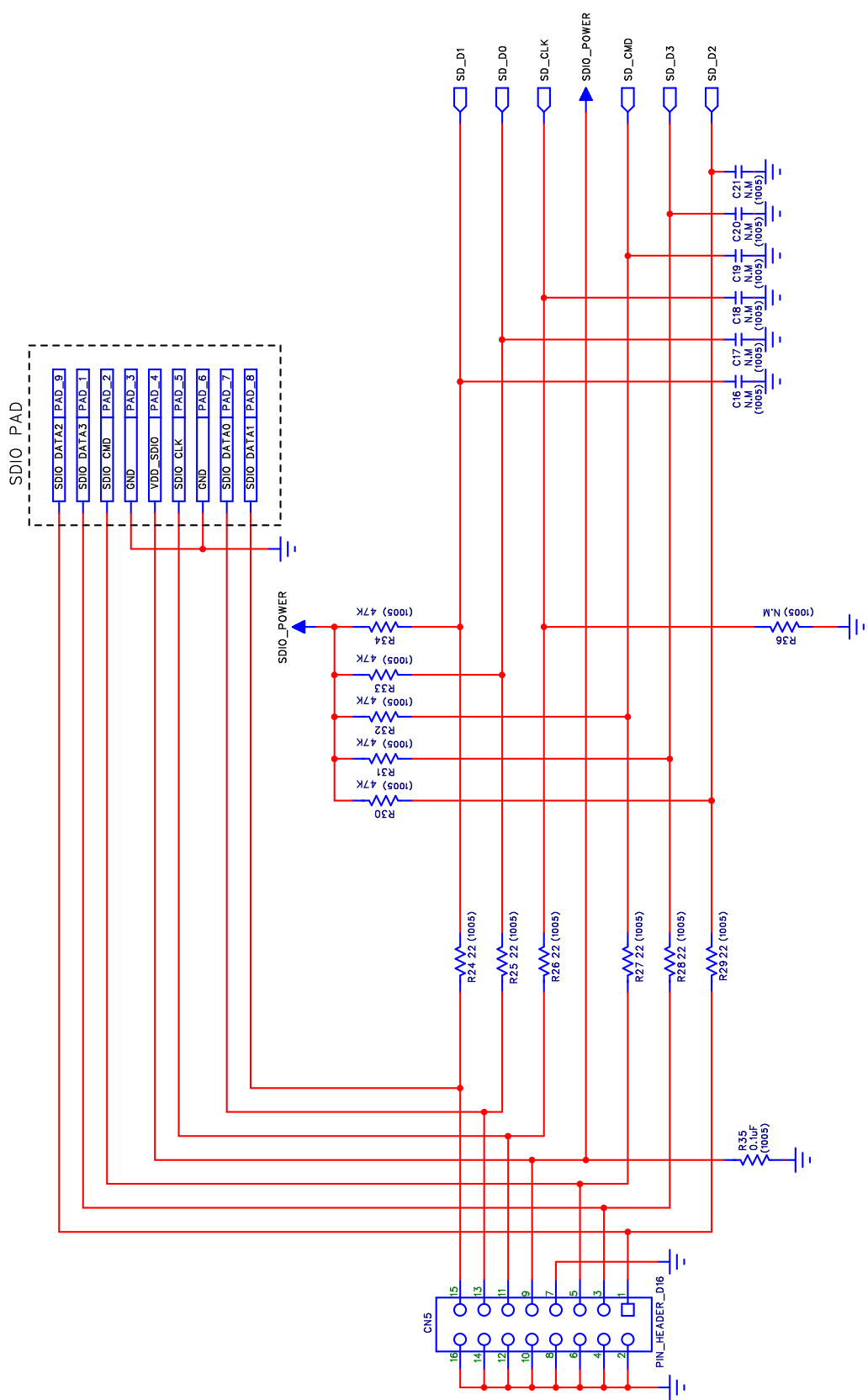

APPROVED:	Title	Document No.
CHECKED :	Circuit schematic	HD-MC-
DRAWN :		BTE8804
DESIGNED :		(2/3)

REV	ECO	APPROVED	DESCRIPTION	DATE

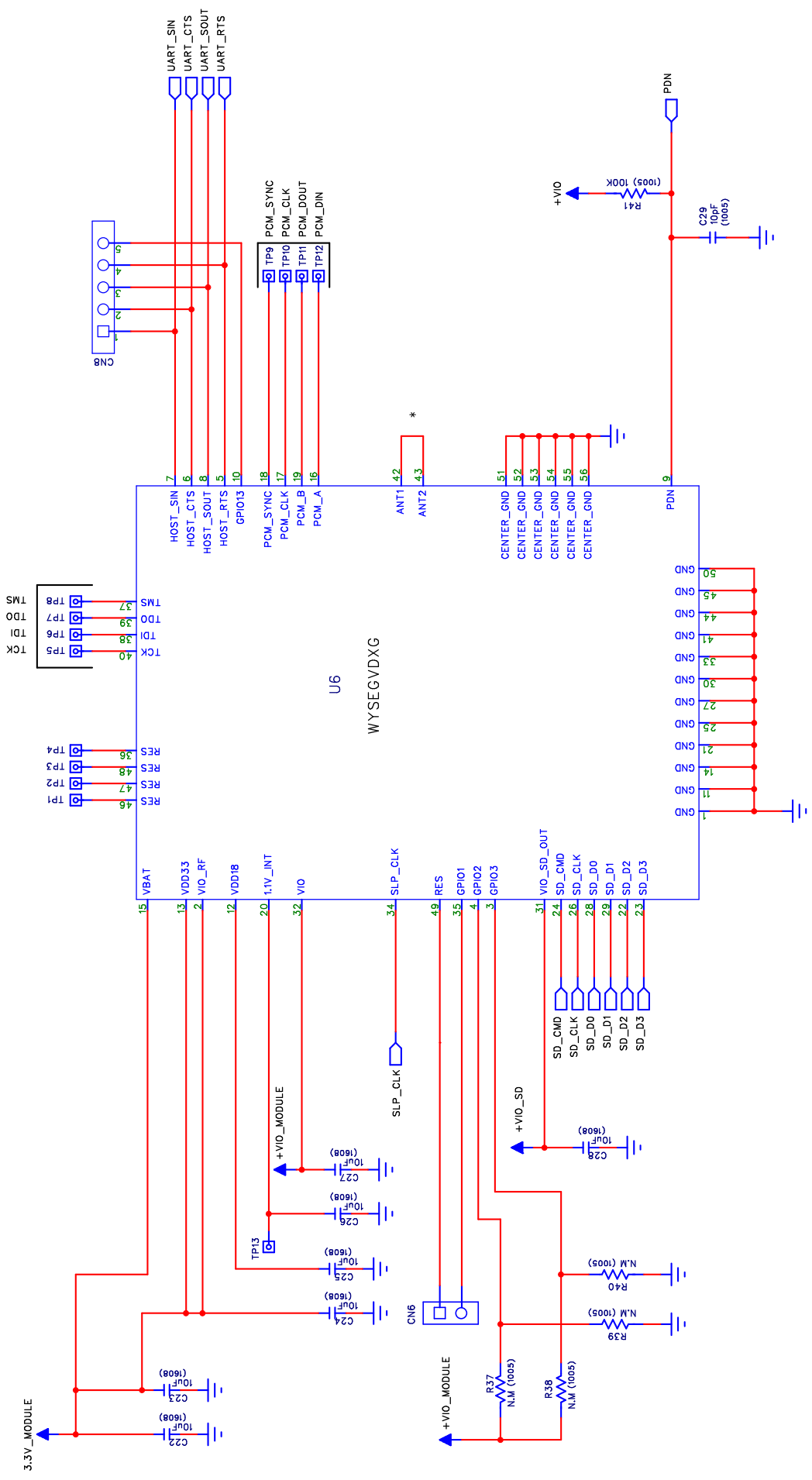

APPROVED :	Title	Document No.
CHECKED :	Circuit schematic	HD-MC-
DRAWN :		BTE8804
DESIGNED :		(3/3)

# ***Evaluation guide book of TAIYO YUDEN Wireless Module on the ESPRESSObin (88W8887)***

Version 1.2: 19-Jun-2020

1. BLOCK DIAGRAM FOR H/W .....	2
2. OPEN SERIAL CONSOLE ON THE PC.....	4
3. POWER ON THE ESPRESSOBIN .....	5
4. LOAD WLAN AND BLUETOOTH DRIVER.....	6
4.1 WLAN OPERATION CHECK.....	7
4.2 BLUETOOTH OPERATION CHECK .....	10
4.3 WPA_SUPPLICANT OPERATION CHECK .....	10
4.4 HOSTAPD OPERATION CHECK .....	11
5. MANUFACTURING UTILITY (MFG) .....	12
5.1 WIRED NETWORK SETTINGS .....	12
5.2 LOAD WLAN AND BLUETOOTH DRIVER WITH MFG FIRMWARE .....	12
5.3 RUN “MFG BRIDGE” APPLICATION .....	13
6. ABOUT SDIO SWITCHING .....	15

1. Block Diagram for H/W

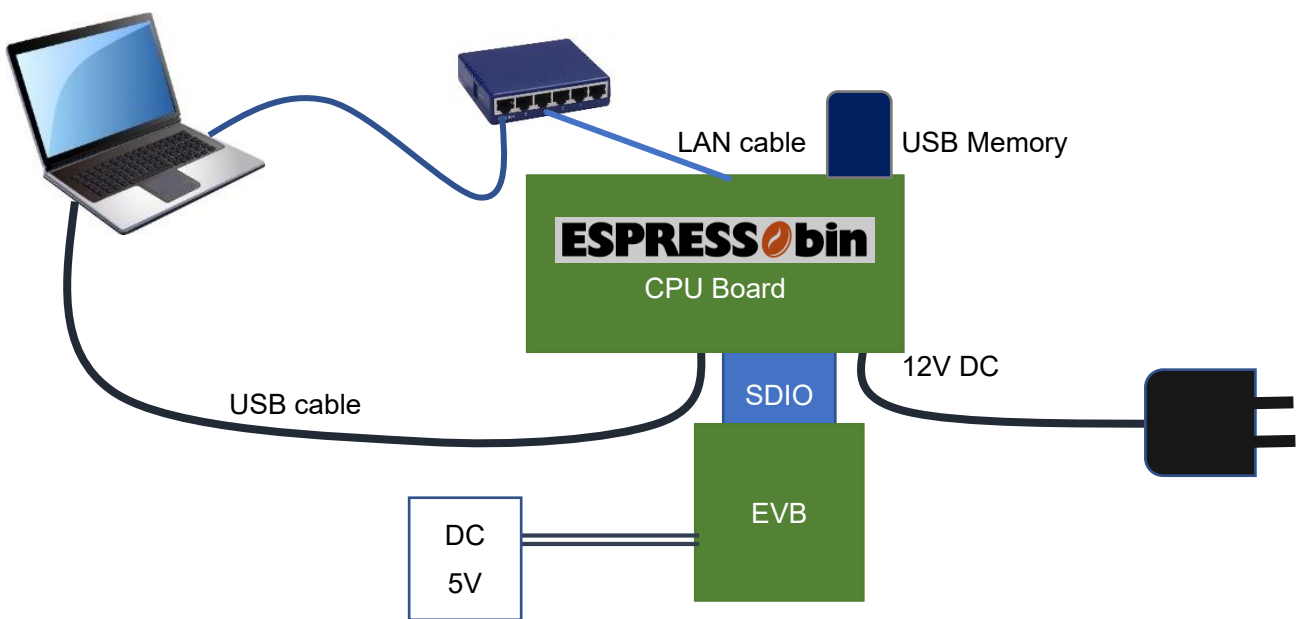

# Detailed Block Diagram

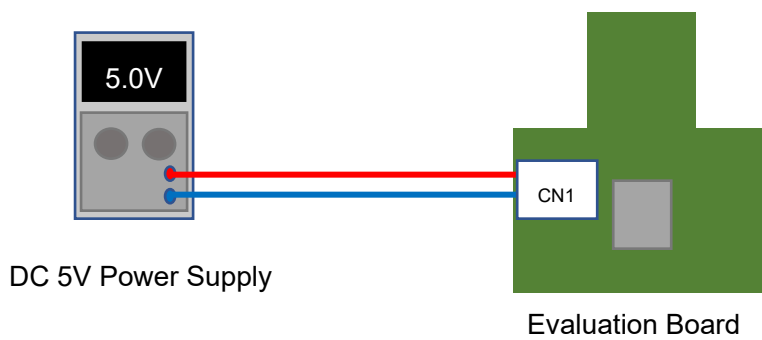
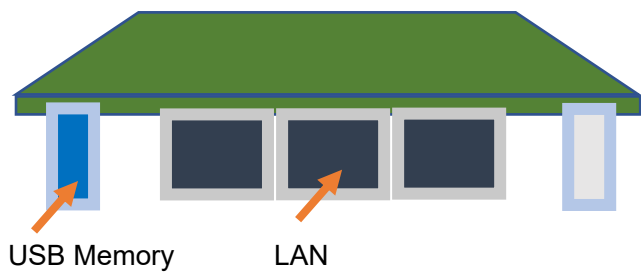
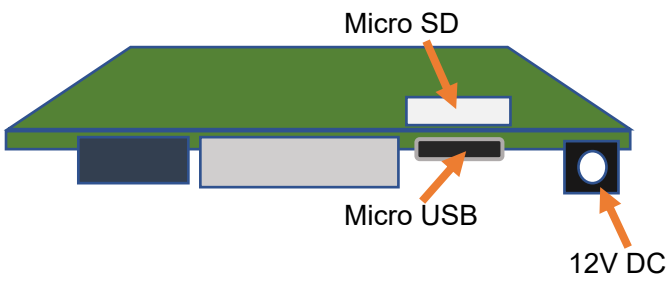

## 2. Open serial console on the PC

First connect the ESPRESSObin and the PC with the USB cable.

ESPRESSObin power supply remains OFF.

Open the corresponding port with serial communication software. (terminal software)

Follow the tutorial for your OS to make sure you have everything needed.

Windows:

<http://wiki.espressobin.net/tiki-index.php?page=Serial+connection+-+Windows>

Linux

<http://wiki.espressobin.net/tiki-index.php?page=Serial+connection+-+Linux>

*For example*

*Tera Term on the Windows PC*

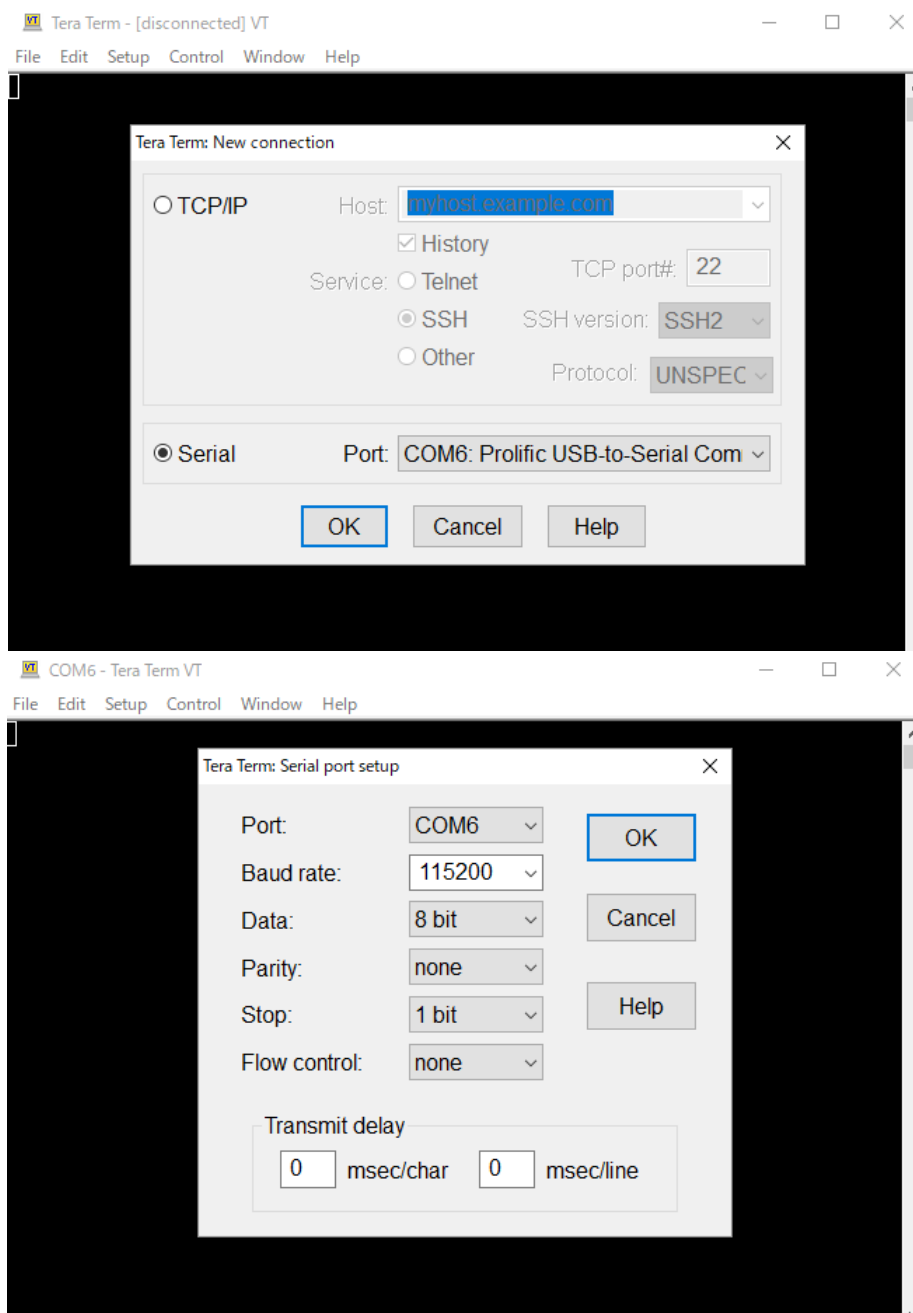

### 3. Power on the ESPRESSObin

Plug your power adapter to the 12V DC Jack.

When the ESPRESSObin starts to boot, you can check following messages.

```
TIM-1.0
WTMI-armada-17.10.1-b90dbf0
ENTER init_ddrgen
DDR_TOPOLOGY is 4 :    DDR3, 1CS 1G
WTMI_CLOCK=2
    ⏪ (skip)
MMC:   sdhci@d0000: 0, sdhci@d8000: 1
SF: Detected w25q32dw with page size 256 Bytes, erase size 4 KiB, total 4 MiB
Net:   eth0: neta@30000 [PRIME]
Hit any key to stop autoboot:  0
    Please press "ENTER" key when the above message is displayed.
Marvell>>
```

Enter the following in order. (**Blue** letter part)

```
Marvell>> run bootusb
starting USB...
USB0:   Register 2000104 NbrPorts 2
Starting the controller
    ⏪ (skip)
Ubuntu 14.04 LTS localhost.localdomain ttyMV0

localhost login: root (automatic login)

Last login: Thu Jan  1 00:00:20 UTC 1970 on ttyMV0
Welcome to Ubuntu 14.04.5 LTS (GNU/Linux 4.4.8-armada-17.02.2-g8148be9-dirty aarch64)
```

When the ESPRESSObin starts normally, you can check above message.

“bootusb” works with SDIO 3.0. (ultra-high speed)

If you want to operate with SDIO 2.0 (high speed), please change to "bootusbH". (**run bootusbH**)

Refer to “6. About SDIO switching” for setting on the evaluation board.

#### 4. Load WLAN and Bluetooth driver

```
root@localhost:~# cd /home/8887/bin_sd8887
root@localhost:/home/8887/bin_sd8887# insmod mlan.ko
root@localhost:/home/8887/bin_sd8887# insmod sd8887.ko cal_data_cfg=none
[ 169.071741] wlan: Loading MWLAN driver
[ 169.076218] wlan: Driver loaded successfully
root@localhost:/home/8887/bin_sd8887# cd ../bin_sd8887_bt/
root@localhost:/home/8887/bin_sd8887_bt# insmod bt8887.ko
[ 178.215970] BT: Loading driver
[ 178.219525] BT: Driver loaded successfully
root@localhost:/home/8887/bin_sd8887_bt#
```

Insert 88w8887 evaluation board into SDIO of ESPRESSObin.  
Please note that it is easy to come off.



Turn on the power of evaluation board

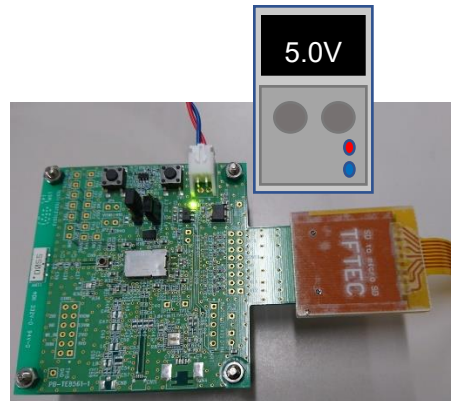

The evaluation board will be recognized and the following message will be displayed.

```
root@localhost:/home/8887/bin_sd8887_bt# [ 68.499234] vendor=0x02DF device=0x9135 class=0 function=1
[ 68.504945] SDIO: max_segs=128 max_seg_size=65536
[ 68.509804] rx_work=1 cpu_num=2
[ 68.524226] Request firmware: mrvl/sd8887_uapsta_a2.bin
[ 69.651638] WLAN FW is active
[ 74.665275] wlan: version = SD8887-15.68.7.p189-C4X15C605-GPL-(FP68)
[ 74.673418] ahci-mvebu d00e0000.sata: couldn't get PHY in node sata: -517
[ 74.696088] orion-ehci d005e000.usb: init d005e000.usb fail, -517
[ 74.721036] ahci-mvebu d00e0000.sata: couldn't get PHY in node sata: -517
root@localhost:/home/8887/bin_sd8887_bt#
```

When the driver install succeed, you can check “WLAN FW is active” message.

\*If “WLAN FW is active” is not displayed, power off evaluation board, remove the evaluation board from the SD slot, insert it in the SD slot again, and turn the power of the evaluation board on again.

#### 4.1 WLAN operation check

##### Confirmation of wireless LAN interface

```
root@localhost:/home/8887/bin_sd8887_bt# iwconfig
```

```
m1an0 IEEE 802.11-DS ESSID:""  
Mode:Managed Access Point: Not-Associated Bit Rate:1 Mb/s  
Tx-Power=17 dBm  
Retry limit:9 RTS thr=2347 B Fragment thr=2346 B  
Encryption key:off  
Power Management:on  
Link Quality=0/5 Signal level=0 dBm Noise level=0 dBm  
Rx invalid nwid:0 Rx invalid crypt:0 Rx invalid frag:0  
Tx excessive retries:0 Invalid misc:0 Missed beacon:0  
  
wfd0 IEEE 802.11-DS ESSID:""  
Mode:Managed Access Point: Not-Associated Bit Rate:1 Mb/s  
Tx-Power=17 dBm  
Retry limit:9 RTS thr=2347 B Fragment thr=2346 B  
Encryption key:off  
Power Management:on  
Link Quality=0/5 Signal level=0 dBm Noise level=0 dBm  
Rx invalid nwid:0 Rx invalid crypt:0 Rx invalid frag:0  
Tx excessive retries:0 Invalid misc:0 Missed beacon:0  
  
uap0 IEEE 802.11-DS ESSID:""  
Mode:Master Frequency:2.437 GHz Access Point: Not-Associated  
Encryption key:off  
Link Quality:0 Signal level:0 Noise level:0  
Rx invalid nwid:0 Rx invalid crypt:0 Rx invalid frag:0  
Tx excessive retries:0 Invalid misc:0 Missed beacon:0
```

Perform a "scan"

root@localhost:/home/8887/bin\_sd8887\_bt# iwlist wlan0 scan

wlan0 Scan completed :

Cell 01 - Address: 1C:\*.:.:.:.:.:.\*

ESSID:"WG1400HP-2G" [4]

Mode:Master

Frequency=2.417 GHz (Channel 2)

Quality:5/5 Signal level:-45 dBm Noise level:-96 dBm

Encryption key:on

Bit Rates:1 Mb/s; 2 Mb/s; 5.5 Mb/s; 11 Mb/s; 6 Mb/s

9 Mb/s; 12 Mb/s; 18 Mb/s; 24 Mb/s; 36 Mb/s

48 Mb/s; 54 Mb/s

Extra:Beacon interval=100

IE: IEEE 802.11i/WPA2 Version 1

Group Cipher : CCMP

Pairwise Ciphers (1) : CCMP

Authentication Suites (1) : PSK

Cell 02 - Address: 1C:\*.:.:.:.:.:.\*

ESSID:"WG1400HP-5G" [24]

Mode:Master

Frequency=5.18 GHz (Channel 36)

Quality:5/5 Signal level:-42 dBm Noise level:-96 dBm

Encryption key:on

Bit Rates:6 Mb/s; 9 Mb/s; 12 Mb/s; 18 Mb/s; 24 Mb/s

36 Mb/s; 48 Mb/s; 54 Mb/s

Extra:Beacon interval=100

IE: IEEE 802.11i/WPA2 Version 1

Group Cipher : CCMP

Pairwise Ciphers (1) : CCMP

Authentication Suites (1) : PSK



## 4.2 Bluetooth operation check

### Confirmation of wireless Bluetooth interface

```
root@localhost:/home/8887/bin_sd8887_bt# hciconfig
hci0:  Type: BR/EDR  Bus: SDIO
       BD Address: AC:3F:A4:84:D1:89  ACL MTU: 1021:7  SCO MTU: 120:6
       UP RUNNING PSCAN
       RX bytes:918 acl:0 sco:0 events:42 errors:0
       TX bytes:1182 acl:0 sco:0 commands:42 errors:0
```

### Perform a "inquiry" and "connection"

```
root@localhost:/home/8887/bin_sd8887_bt# hcitool -i hci0 scan
```

Scanning ...

```
XX:D2:24:BA:9C:02      n/a
XX:E0:10:E2:48:89     n/a
XX:CB:57:6A:9A:5C     n/a
E4:A7:A0:4A:C7:42     H00028472-PC
```

```
root@localhost:/home/8887/bin_sd8887_bt# hcitool -i hci0 cc E4:A7:A0:4A:C7:42
```

```
root@localhost:/home/8887/bin_sd8887_bt# hcitool -i hci0 con
```

Connections:

```
< ACL E4:A7:A0:4A:C7:42 handle 1 state 1 lm SLAVE
```

## 4.3 wpa\_supplicant operation check

```
root@localhost:/home/8887/bin_sd8887_bt# cd /home/wpa_supplicant/
```

```
root@localhost:/home/wpa_supplicant# wpa_supplicant -Dwext -imlan0 -c ./wpa01.conf
```

Successfully initialized wpa\_supplicant

rftkill: Cannot open RFKILL control device

ioctl[SIOCSIWESSID]: Bad address

mlan0: Trying to associate with 1c:b1:7f:e4:82:22 (SSID='WG1400HP-2G' freq=2417 MHz)

mlan0: Associated with 1c:b1:7f:e4:82:22

mlan0: WPA: Key negotiation completed with 1c:b1:7f:e4:82:22 [PTK=CCMP GTK=CCMP]

mlan0: CTRL-EVENT-CONNECTED - Connection to 1c:b1:7f:e4:82:22 completed [id=0 id\_str=]

\*Please create "conf" file according to your environment and use it.

#### 4.4 hostapd operation check

Confirmation of hostapd is done by loading WLAN driver.

```
root@localhost:~# cd /home/hostapd/bin_sd8887_hostapd/
root@localhost:/home/hostapd/bin_sd8887_hostapd# insmod mlan.ko
root@localhost:/home/hostapd/bin_sd8887_hostapd# insmod sd8887.ko cal_data_cfg=none
[ 48.945206] wlan: Loading MWLAN driver
[ 48.950034] wlan: Driver loaded successfully
root@localhost:/home/hostapd/bin_sd8887_hostapd# [ 67.816250] vendor=0x02DF device=0x9135 class=0
function=1
[ 67.821827] SDIO: max_segs=128 max_seg_size=65536
[ 67.826581] rx_work=1 cpu_num=2
[ 67.833097] Request firmware: mrvl/sd8887_uapsta_a2.bin
[ 68.959540] WLAN FW is active
[ 73.962215] creating custom regulatory domain failed
[ 73.990290] wlan: version = SD8887-15.68.7.p189-C4X15C605-GPL-(FP68)
[ 73.998035] orion-ehci d005e000.usb: init d005e000.usb fail, -517
[ 74.006669] ahci-mvebu d00e0000.sata: couldn't get PHY in node sata: -517
[ 74.049723] orion-ehci d005e000.usb: init d005e000.usb fail, -517
[ 74.057792] ahci-mvebu d00e0000.sata: couldn't get PHY in node sata: -517
```

\*Please create "conf" file according to your environment and use it.

```
root@localhost:/home/hostapd/bin_sd8887_hostapd# cd ..
root@localhost:/home/hostapd# hostapd ./test_hostapd.conf
Configuration file: ./test_hostapd.conf
rfkill: Cannot open RFKILL control [ 246.128457] get_channel when AP is not started device
[ 246.137962] get_channel when AP is not started
[ 246.143303] get_channel when AP is not started
uap0: interface state UNINITIALIZED->COUNTRY_UPDATE
Using interface uap0 with hwaddr ac:3f:a4:84:d2:88 and ssid "ESP_AP_test"
[ 246.233170] wlan: Starting AP
[ 246.248426] wlan: AP started
[ 246.253711] Set AC=3, txop=47 cwmin=3, cwmax=7 aifs=1
[ 246.259356] Set AC=2, txop=94 cwmin=7, cwmax=15 aifs=1
[ 246.265744] Set AC=0, txop=0 cwmin=15, cwmax=63 aifs=3
[ 246.271371] Set AC=1, txop=0 cwmin=15, cwmax=1023 aifs=7
uap0: interface state COUNTRY_UPDATE->ENABLED
uap0: AP-ENABLED
uap0: STA e4:a7:a0:4a:c7:3e IEEE 802.11: associated ← Connection from client (station)
uap0: AP-STA-CONNECTED e4:a7:a0:4a:c7:3e
uap0: STA e4:a7:a0:4a:c7:3e RADIUS: starting accounting session 00000041-00000000
uap0: STA e4:a7:a0:4a:c7:3e WPA: pairwise key handshake completed (RSN)
```

## 5. Manufacturing utility (MFG)

\*Please restart ESPRESSObin before MFG operation.

### 5.1 Wired network settings



**Windows PC**  
192.168.1.100



```
root@localhost:~# ifconfig eth0 up
root@localhost:~# ifconfig lan0 192.168.1.10 up
You can set the IP address arbitrarily.
```

\*If eth0 cannot be updated, refer to the notes.  
(This is the last page)

### 5.2 Load WLAN and Bluetooth driver with MFG firmware

```
root@localhost:~# cd /home/8887/bin_sd8887
root@localhost:/home/8887/bin_sd8887# insmod mlan.ko
root@localhost:/home/8887/bin_sd8887#
insmod sd8887.ko cal_data_cfg=none mfg_mode=1 fw_name=mrvl/sdio8887_sdio_combo.bin
[ 127.544784] wlan: Loading MWLAN driver
[ 127.552974] wlan: Driver loaded successfully
root@localhost:/home/8887/bin_sd8887# cd ../bin_sd8887_bt/
root@localhost:/home/8887/bin_sd8887_bt# insmod bt8887.ko
[ 287.204131] BT: Loading driver
[ 287.207515] BT: Driver loaded successfully
```

Turn on the power of the evaluation board and insert it into SDIO of ESPRESSObin.

```
root@localhost:/home/8887/bin_sd8887_bt#
[ 328.904607] vendor=0x02DF device=0x9135 class=0 function=1
[ 328.912467] SDIO: max_segs=128 max_seg_size=65536
[ 328.917119] rx_work=1 cpu_num=2
[ 328.925621] Request firmware: mrvl/sdio8887_sdio_combo.bin
[ 329.963455] WLAN FW is active
[ 329.985829] IOCTL failed: fffffc038154800 id=0x20000, sub_id=0x20006 action=1, status_code=0x2
[ 329.994793] set mac address failed! status=-1, error_code=0x2
[ 330.011301] wlan: version = SD8887-0.0.0.p0-C4X15C605-GPL-(FP68)
[ 330.021305] ahci-mvebu d00e0000.sata: couldn't get PHY in node sata: -517
[ 330.030038] orion-ehci d005e000.usb: init d005e000.usb fail, -517
[ 330.053699] ahci-mvebu d00e0000.sata: couldn't get PHY in node sata: -517
[ 330.069738] orion-ehci d005e000.usb: init d005e000.usb fail, -517
```

### 5.3 Run "MFG Bridge" application

```
root@localhost:/home/8887/bin_sd8887_bt# cd ../bin_mfgbridge/  
root@localhost:/home/8887/bin_mfgbridge# ./mfgbridge  
UART: initialize ...  
Can't get port settings: Input/output error  
NET: initialize ...  
NET: socket bind is completed!  
NET: initialization is completed.  
NET: server port: 9930  
NET: client port: 9931
```

Execute "DutApi\_w8887\_BrdigeEth.exe" on the Windows PC side.  
 (Please refer to " 8887\_MFG\_Bridge\_User\_Guide" for details. It can be download from Taiyo Yuden's web site. At first, please register according to the procedure described in the document enclosed with this evaluation kit.)

```

NET: new connection from 192.168.1.100
Initialize drvwrapper ....
no nfc /dev/mnfcchar0no nfc /dev/mfmchar0Initialize drvwrapper for BT ....
DRV: driver is initialized.
NET: socket FD = 5
NET: receive a packet (bytes = 40)
BRDG: process Rx msg ...
NET: WLAN command.
DRV: send host cmd thr ioctl
DRV: host cmd is completed
NET: send a msg.
NET: the msg is sent.
NET: socket FD = 5
NET: receive a packet (bytes = 36)
BRDG: process Rx msg ...
NET: WLAN command.
DRV: send host cmd thr ioctl
DRV: host cmd is completed
NET: send a msg.
NET: the msg is sent.
NET: socket FD = 5
NET: receive a packet (bytes = 0)
NET: close client socket
De-Initialize drvwrapper for BT....
De-Initialize drvwrapper ....
NET: socket FD = 4
NET: new connection from 192.168.1.100
Initialize drvwrapper ....
no nfc /dev/mnfcchar0no nfc /dev/mfmchar0Initialize drvwrapper for BT ....
DRV: driver is initialized.
NET: socket FD = 5
NET: receive a packet (bytes = 16)
BRDG: process Rx msg ...
HCI Command
Rx Event E for 09 10
In Cmd 09 10
NET: send a msg.
NET: the msg is sent.
    
```

```

Name:      Dut |abtool
Version:   2.0.0.96
Date:      May 2 2017 (11:53:53)

Note:
1. =====WiFi tool=====
2. =====BT tool=====
3. =====FM tool=====
4. =====NFC tool=====

Enter CMD 99 to Exit
Enter option: 1
    
```

```

Enter option: 1
Name:      DutApiClass
Interface: Ethernet
Version:   2.0.0.96
Date:      May 2 2017 (11:53:34)

Note:
C:\Users\Yjt0011083\Downloads\ESPRESSO\bin\MFG-W8887-MF-WIFI-BT-FM-BRG-FC-WIN-X86-2.0.0.96-15.2.7.p123\bin\relea
#setup.ini
Dut's IP 192.168.1.10:9930
Host's IP 192.168.1.100:9931
DutIf_UdpIp::delay 0
DutIf_UdpIp::vg_IfSpy 0
TCP connecting...
DutIf_InitConnection: 0

-----
W87xx (802.11a/g/b/n/ac) TEST MENU
-----
Enter option:
    
```

```

-----
W87xx (802.11a/g/b/n/ac) TEST MENU
-----
Enter option: 45
DutIf_GetMACAddress: 0x00000000
DutIf_GetMACAddress: ac.3f.a4.84.d1.88
Enter option:
    
```

```

Enter option: 99
Exiting
DutIf_Disconnection: 0
1. =====WiFi tool=====
2. =====BT tool=====
3. =====FM tool=====
4. =====NFC tool=====

Enter CMD 99 to Exit

Enter option: 2
Name:      DutApiClass
Interface: Version: 2.0.0.96
Date:      May 2 2017 (11:53:36)

Note:
C:\Users\Yjt0011083\Downloads\ESPRESSO\bin\MFG-W8887-MF-WIFI-BT-FM-BRG-FC-WIN-X86-2.0.0.
#setup.ini
Dut's IP 192.168.1.10:9930
Host's IP 192.168.1.100:9931
DutIf_UdpIp::delay 0
DutIf_UdpIp::vg_IfSpy 0
TCP connecting...
Dut_Bt_OpenDevice: 0x00000000

-----
W87xx (BT) TEST MENU
-----

Enter option: 45
45
Dut_Bt_GetBDAddress: 0x00000000
BD_ADDRESS: AC-3F-A4-84-D1-89
Enter option:
    
```

## 6. About SDIO switching

This is the setting of SDIO bus speed switching on each evaluation board.

CN3(WBSBHVXG) / CN2(WBSA(E)GVDXG) : VIO\_SD Voltage Select

No.	Pin name	Direction	Description
1	3.3V	Output	3.3V output. (high speed)
2	VIO	Input	Input for VIO_SD.
3	1.8V	Output	1.8V output. (ultra-high speed)

Setting: 1-2 short -> high speed

Setting: 2-3 short -> ultra-high speed

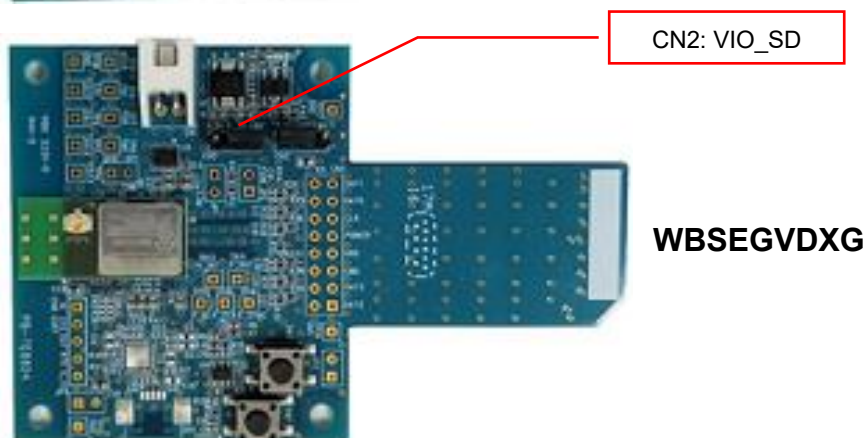
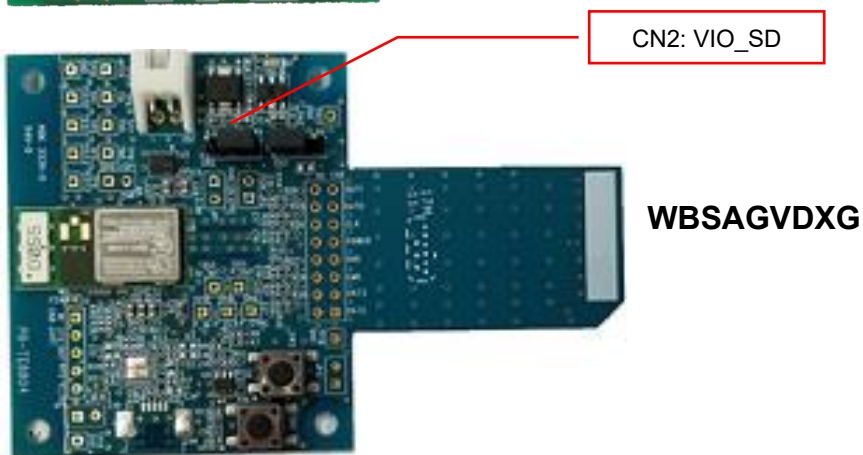
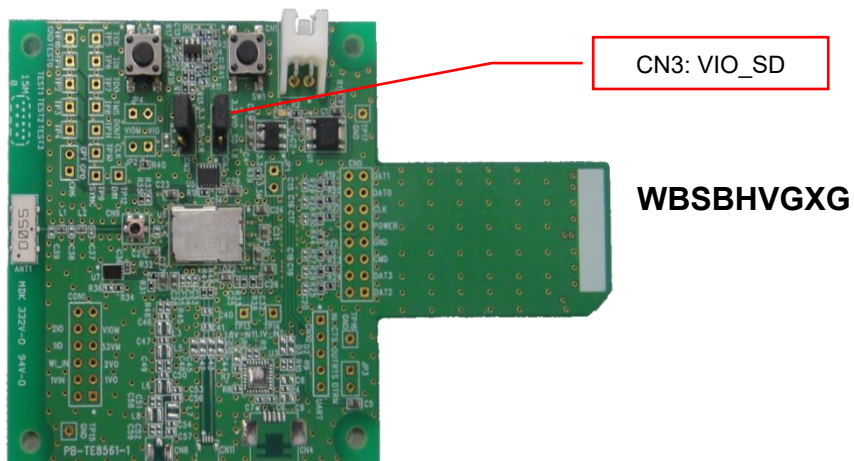

Notes.

About "5.1 Wired network settings".

If an error occurs with "ifconfig eth0 up", perform the following procedure.

```
root@localhost:~# iwconfig
```

```
bond0      no wireless extensions.
```

```
lan0      no wireless extensions.
```

```
wan       no wireless extensions.
```

```
lan1      no wireless extensions.
```

```
lo        no wireless extensions.
```

```
eth5     no wireless extensions.
```

```
root@localhost:~# ifconfig eth5 up
```

Use ethX displayed in "iwconfig" instead of eth0.